

TECHNICAL MANUAL

**OPERATOR'S, ORGANIZATIONAL, DIRECT SUPPORT,
AND GENERAL SUPPORT
MAINTENANCE MANUAL
(INCLUDING REPAIR PARTS AND SPECIAL TOOLS LISTS)
FOR
GENERATOR, TRACKING SG-1125/U
(HEWLETT-PACKARD MODEL 8444A)
(NSN 6625-00-185-4802)**

HEADQUARTERS, DEPARTMENT OF THE ARMY

29 FEBRUARY 1980

CHANGE }
No. 1 }

HEADQUARTERS
DEPARTMENT OF THE ARMY
WASHINGTON, DC, 28 August 1980

**Operator's, Organizational, Direct Support, and General Support
Maintenance Manual
(Including Repair Parts and Special Tools Lists)
For
GENERATOR, TRACKING SG-1125/U
(HEWLETT-PACKARD MODEL 8444A)
(NSN 6625-00-185-4802)**

TM 11-6625-2866-14&P, 29 February 1980, is changed as follows:

1. Remove old pages and insert new pages as indicated below:

<i>Remove</i>	<i>Insert</i>
None	6-9 through 6-11/(6-12 blank)
F-1	F-1 through F-3/(F-4 blank)
G-1	G-1 and G-2
None	H-3 through H-5/(H-6 blank)

2. File this sheet in front of the manual for reference purposes.

By Order of the Secretary of the Army:

E. C. MEYER
General, United States Army
Chief of Staff

Official:

J. C. PENNINGTON
Major General, United States Army
The Adjutant General

Distribution:

Active Army:

HISA (Ft Monmouth) (21)	USAICS (3)
USAINSCOM (2)	MAAG (1)
COE (1)	USARMIS (1)
TSG (1)	USAERDAA (1)
USAARENBD (1)	USAERDAW (1)
DARCOM (1)	Fort Gordon (10)
TRADOC (2)	Fort Carson (5)
OS Maj Comd (4)	Army Dep (1) except
TECOM (2)	LBAD (14)
USACC (4)	SAAD (30)
MDW (1)	TOAD (14)
Armies (2)	SHAD (3)
Corps (2)	Fort Gillem (10)
Svc Colleges (1)	USA Dep (1)
USASIGS (5)	Sig Sec USA Dep (1)
USAADS (2)	Fort Richardson (CERCOM Ofc) (2)
USAFAS (2)	Units org under fol TOE:
USAARMS (2)	(2 copies each unit)
USAIS (2)	29-207
USAES (2)	29-610

ARNG: None

USAR: None

For explanation of abbreviations used, see AR 310-50.

This manual contains copyright material reproduced by permission of the Hewlett-Packard Company.

TM 11-6625-2866-14&P

TECHNICAL MANUAL
No. 11-6625-2866-14&P



HEADQUARTERS
DEPARTMENT OF THE ARMY
WASHINGTON, DC, 29 February 1980

**OPERATOR'S, ORGANIZATIONAL, DIRECT
SUPPORT, AND GENERAL SUPPORT
MAINTENANCE MANUAL
(INCLUDING REPAIR PARTS AND SPECIAL TOOLS LISTS)
FOR
GENERATOR, TRACKING SG-1 125/U
(HEWLETT-PACKARD MODEL 8444A)
(NSN 6625-00-185-4802)**

REPORTING ERRORS AND RECOMMENDING IMPROVEMENTS

You can improve this manual by recommending improvements using DA Form 2028-2 (Test) located in the back of the manual. Simply tear out the self-addressed form, fill it out as shown on the sample, fold it where shown, and drop it in the mail. If there are no blank DA Forms 2028-2 (Test) in the back of your manual, use the standard DA Form 2028 (Recommended Changes to Publications and Blank Forms) and forward to the Commander, US Army Communications and Electronics Materiel Readiness Command, ATTN: DRSEL-ME-MQ, Fort Monmouth, NJ 07703.

In either case a reply will be furnished direct to you.

This manual is an authentication of the manufacturer's commercial literature which, through usage, has been found to cover the data required to operate and maintain this equipment. Since the manual was not prepared in accordance with military specifications, the format has not been structured to consider levels of maintenance.

TABLE OF CONTENTS

Section	Page	Section	Page
0. INTRODUCTION	0-1	141T/84, 44A System	
I. GENERAL INFORMATION.....	1-1	4-9. Preset Adjustments (8555A/8552B/ 141T/8444A System).....	4-2
1-1. Introduction	1-1	4-11. Performance Tests	4-2
1-5. Safety Considerations	1-1	4-16. Output Level.....	4-3
1-16. Instruments Covered by Manual	1-2	4-17. Frequency Stability	4-5
1-18. Description	1-2	4-18. System Flatness	4-9
1-21. 8554B RF Section Modifications.....	1-4	4-19. -Frequency Accuracy.....	4-11
1-23. Accessories Supplied	1-4	4-20. Harmonic Distortion.....	4-13
1-25. Operating Accessories.....	1-4	V. ADJUSTMENTS .5	5-1
1-27. Warranty	1-4	5-1. Introduction	5-1
1-29. Recommended Test Equipment	1-4	5-4. Equipment Required.....	5-1
II. INSTALLATION	2-1	5-6. Factory Selected Components.....	5-1
2-1. Initial Inspection	2-1	5-8. Power Supply, Check and Adjustment	5-1
2-2. Mechanical Check	2-1	5-9. 1.55 GHz Oscillator Power Level, Frequency Check & Adjustment.	5-4
2-4. Electrical Check	2-1	5-10. 1.55 GHz Oscillator Residual FM Check	5-6
2-6. Claims for Damage.	2-1	5-11. First Converter Check and Adjustment	5-9
2-9. Preparation for Use.	2-1	5-12. Automatic Level Control (ALC) Check and Adjustment	5-11
2-10. Power Requirements	2-1	5-13. Level Control Calibration Check and Adjustment	5-13
2-13. Power Cable.....	2-1	VI. REPLACEABLE PARTS	6-1
2-16. Operating Environment	2-1	6-1. Introduction	6-1
2-18. Installation Connections.....	2-2	6-3. Abbreviations.....	6-1
2-21. Storage and Shipment.....	2-2	6-5. Replaceable Parts List.....	6-1
2-22. Original Packaging	2-2	6-7. Ordering Information	6-1
2-26. Other Packaging Materials	2-2	VII. MANUAL CHANGES	7-1
III. OPERATION	3-1	7-1. Introduction	7-1
3-1. Introduction	3-1	7-5. Manual Change Instructions	7-1
3-3. Panel Features.....	3-1	VIII. SERVICE	8-1
3-5. Operator's Checks	3-1	8-1. Introduction	8-1
3-7. Operating Instructions	3-1	8-3. Principles of Operation	8-1
3-9. Controls, Indicators and Connectors .	3-1	8-5. Recommended Test Equipment	8-1
3-11. Operating Techniques.....	3-1	8-7. Troubleshooting.....	8-1
3-13. Crystal Filter Measurement.....	3-8	8-11. Repair	8-1
3-15. Bandpass Filter Measurement	3-8	8-20. General Service Hints	8-2
3-17. Low-Pass Filter Measurement	3-8	8-23. General Service Information.....	8-4
3-19. Swept Return Loss Measurement	3-9	8-28. Operational Amplifiers.....	8-5
3-21. Amplifier Gain and Bandwidth Measurement.....	3-9	8-31. Electrical Maintenance	8-6
3-23. Precision Frequency Measurements .	3-9		
IV. PERFORMANCE TESTS	4-1		
4-1. introduction	4-1		
4-3. Equipment Required.....	4-1		
4-5. Front Panel Checks	4-1		
4-7. Preset Adjustments (8554B/8552B			

Contents

LIST OF ILLUSTRATIONS

Figure	Page	Figure	Page
1-1. Model 8444A Tracking Generator and Accessories	1-0	7-2. First Converter Circuits, Schematic Diagram ..	7-5
1-2. Instrument Identification	1-2	7-3. A7 1.55 GHz Oscillator Assembly, Illustrated Parts Breakdown	7-6
2-1. Power Cable Line Connector Labels.	2-2	8-1. Transistor Operation.	8-5
3-1. Model 8444A Tracking Generator Front Panel Controls, Indicators and Connectors	3-2	8-2. Examples of Diode and Transistor Marking Methods	8-6
3-2. Model 8444A Tracking Generator Rear Panel Controls and Connectors	3-3	8-3. Operational Amplifier Equivalent Circuit . .	8-7
3-3. Tracking Generator Operation with 8554B Spectrum Analyzer	3-4	8-4. Major Assembly Locations.	8-9
3-4. Tracking Generator Operation with 8555A Spectrum Analyzer	3-6	8-5. Adjustment and Test Point Locations.	8-9
3-5. 20 MHz. Crystal Filter CRT Display.	3-8	8-6. Tracking Generator Spectrum Analyzer, Simplified Block Diagram	8-10
3-6. 50 MHz. Bandpass Filter CRT Display	3-8	8-7. Tracking Generator Block Diagram with Spectrum Analyzer Interconnections.	8-11
3-7. 23 MHz Low-Pass Filter CRT Display.	3-9	8-7A. Troubleshooting Tree	8-12
3-8. Swept Return Loss Measurement CRT Display	3-9	8-8. Tracking Generator Troubleshooting Block Diagram.	8-13
3-9. Amplifier Gain and Bandwidth CRT Display.	3-9	8-9. Mixer Diode Forming Dimensions in Inches	8-14
3-10. Precision Frequency Measurement CRT Display	3-10	8-10. Modulator/Oscillator Driver Assy A2 Component Locations	8-15
4-1. Output Level & Flatness Test Setup.	4-3	8-11. Amplifier and Pin Diode Modulator Assy A4A1 Component Locations	8-15
4-2. Residual FM Test Setup	4-7	8-12. First Converter Circuits Schematic Diagram	8-15
4-3. Demodulation Sensitivity Measurement	4-8	8-13. J1 RF Output Connector, Exploded View.	8-16
4-4. System Flatness Test Setup	4-9	8-14. A2 Modulator/Oscillator Driver Assy, Component Location	8-17
4-5. Frequency Accuracy Test Setup	4-11	8-15. Second Converter Circuits, Schematic Diagram	8-17
4-6. Harmonic Distortion Test Setup	4-13	8-16. AI Power Supply Assy, Component Location	8-19
4-7. Typical Harmonic Distortion CRT Display 0 to 100 MHz.	4-15	8-17. Power Supply and Input Circuit, Schematic Diagram	8-19
4-8. Typical Harmonic Distortion CRT Display 0 to 500 MHz	4-15	8-18. A5 First Converter Assembly Illustrated Parts Breakdown	8-20
5-1. Power Supply Check and Adjustment Test Setup	5-2	8-19. A7 1.55GHz Oscillator Assembly Illustrated Parts Breakdown	8-21
5-2. 1.55 GHz LO Power Level and Frequency Check and Adjustment Test Setup	5-4	D-1. 500 MHz LO Mounting Location and Output Port for the 8444A, Option 058	D-6
5-3. 1.55 GHz LO Residual FM Check Test Setup	5-6	D-2. Location of 500 MHz LO OUTPUT BNC Connector Added on Rear Panel of the 8444A, Option 058.	D-7
5-4. Demodulation Sensitivity Measurement	5-8	D-3. A9 500 MHz Oscillator Assembly, Schematic.	D-8
5-5. First Converter Check and Adjustment Test Setup.	5-9		
5-6. First Converter Passband CRT Display.	5-10		
5-7. Automatic Level Control (ALC) Check and Adjustment Test Setup.	5-11		
5-8. Level Control Calibration Check and Adjustment Test Setup	5-13		
7-1. 1.55 GHz LO Power Level and Check and Adjustment Test Setup	7-2		

Contents

LIST OF TABLES

Table	Page
1-1. System Specifications.....	1-3
1-2. Accessories Supplied.....	1-4
1-3. Test Equipment and Accessories .	1-5
1-4. Operating Accessories	1-7
4-1. Performance Test Record .	4-16
5-1. Check and Adjustment Test Card	5-15
6-1. Reference Designations and Abbreviations.	6-2
6-2. Replaceable Parts	6-4
6-3. Code List of Manufacturers	6-8
6-4. Part Number-National Stock Number Cross Reference Index	6-9

Table	Page
7-1. Manual Changes by Serial Number.....	7-1
8-1. Factory Selected Components	8-2
8-2. Adjustable Components .	8-2
8-3. Schematic Diagram Notes .	8-3
8-4. Etched Circuit Soldering Equipment.....	8-4
D-1. 8444A System Specifications With Option 058	D-1
D-2. Replaceable Parts	D-4

APPENDIXES

A. SERVICE NOTE-P-09602038, P-5086-6025	A-1
B. SERVICE NOTE-P-08444-60019	B-1
C. SERVICE NOTE-8444A-1	C-1
D. MODEL 8444A TRACKING GEN- ERATOR, OPTION 058	D-1
E. REFERENCES	E-1

F. COMPONENTS OF END ITEM LIST	F-1
G. ADDITIONAL AUTHORIZA- TION LIST	G-1
H. MAINTENANCE ALLOCATION	H-1
I. REPAIR PARTS AND SPECIAL TOOLS LISTS	I-1

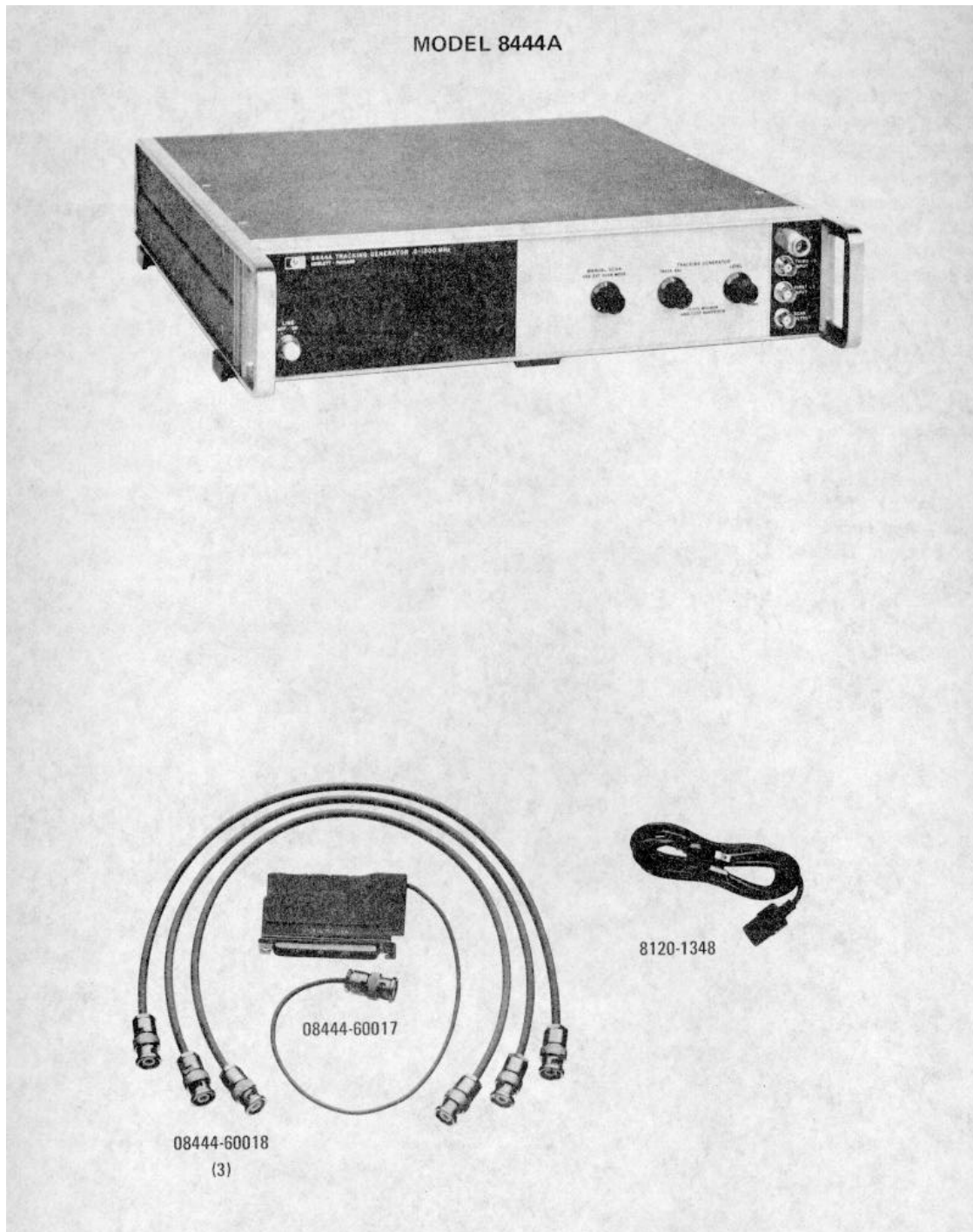

Figure 1-1. Model 8444A Tracking Generator and Accessories

SECTION 0 INTRODUCTION

0-1. SCOPE

This manual describes Generator, Tracking SG-1125/U (Hewlett Packard Model 8444A) and provides instructions for operation and maintenance.

0-2. INDEXES OF PUBLICATIONS

a. DA Pam 310-4. Refer to the latest issue of DA Pam 310-4 to determine whether there are new editions, changes, or additional publications pertaining to the equipment.

b. DA Pam 310-7. Refer to DA Pam 310-7 to determine whether there are modification work orders (MWO's) pertaining to the equipment.

0-3. MAINTENANCE FORMS, RECORDS, AND REPORTS

a. Reports of Maintenance and Unsatisfactory Equipment. Department of the Army forms and procedures used for equipment maintenance will be those described by TM 38-750, The Army Maintenance Management System.

b. Report of Packaging and Handling Deficiencies. Fill out and forward DD Form 6 (Packaging Improvement Report) as prescribed in AR 700-58/NAVSUPINST 4030.29/AFR 71-13/MCO P4030.29A, and DLAR 4145.8.

c. Discrepancy in Shipment Report (DISREP) (SF

361). Fill out and forward Discrepancy in Shipment Report (DISREP) (SF 361) as prescribed in AR 55-38/NAVSUPINST 4610.33B/AFR 75-18/MCO P4610.19C and DLAR 4500.15.

0-4. REPORTING EQUIPMENT IMPROVEMENT RECOMMENDATIONS (EIR)

EIR can and must be submitted by anyone who is aware of an unsatisfactory condition with the equipment design or use. It is not necessary to show a new design or list a better way to perform a procedure; just simply tell why the design is unfavorable or why a procedure is difficult. EIR may be submitted on SF 368 (Quality Deficiency Report). Mail direct to Commander, US Army Communications and Electronics Materiel Readiness Command, ATTN: DRSEL-ME-MQ, Fort Monmouth, NJ 07703. A reply will be furnished to you.

0-5. ADMINISTRATIVE STORAGE

Administrative storage of equipment issued to and used by Army activities shall be in accordance with paragraph .2-16.

0-6. DESTRUCTION OF ARMY ELECTRONICS MATERIEL

Destruction of Army electronics materiel to prevent enemy use shall be in accordance with TM 750-244-2.

SECTION I GENERAL INFORMATION

1-1. INTRODUCTION

1-2. This manual contains all information required to install, operate, test, adjust and service the Hewlett-Packard Model 8444A Tracking Generator. This section covers instrument identification, description, options, accessories, specifications and other basic information.

1-3. Figure 1-1 shows the Hewlett-Packard Model 8444A Tracking Generator with accessories supplied.

1-4. The various sections in this manual provide information as follows:

SECTION II, INSTALLATION, provides information relative to incoming inspection, power requirements, mounting, packing and shipping, etc.

SECTION III, OPERATION, provides information relative to operating the instrument.

SECTION IV, PERFORMANCE TESTS, provides information required to ascertain that the instrument is performing in accordance with published specifications.

SECTION V, ADJUSTMENTS, provides information required to properly adjust and align the instrument after repairs are made.

SECTION VI, REPLACEABLE PARTS, provides ordering information for all replaceable parts and assemblies.

SECTION VII, MANUAL CHANGES, normally will contain no relevant information in the original issue of a manual. This section is reserved to provide back-dated and up-dated information in manual revisions or reprints.

SECTION VIII, SERVICE, includes all information required to service the instrument.

1-5. SAFETY CONSIDERATIONS

1-6. General

1-7. This is an International Electrotechnical Commission Safety Class I instrument. This instrument has been designed and tested according to IEC

Publication 348, "Safety Requirements for Electronic Measuring Apparatus, " and has been supplied in safe condition.

1-8. Operation

1-9. BEFORE APPLYING POWER, make sure the instrument's ac input is set for the available ac line voltage, that the correct fuse is installed, and that all normal safety precautions have been taken.

1-10. Service

1-11. Although the instrument has been designed in accordance with international safety standards, the information, cautions, and warnings in this manual must be followed to ensure safe operation and to keep the instrument safe. Service and adjustments should be performed only by qualified service personnel.

1-12. Adjustment or repair of the opened instrument with the ac power connected should be avoided as much as possible and, when inevitable, should be performed only by a skilled person who knows the hazard involved.

1-13. Capacitors inside the instrument may still be charged even though the instrument has been disconnected from its source of supply.

1-14. Make sure only fuses of the required current rating and type (normal blow, time delay, etc.) are used for replacement. Do not use repaired fuses or short circuit the fuse holders.

1-15. Whenever it is likely that the protection has been impaired, make the instrument inoperative and secure it against any unintended operation.

WARNING

If this instrument is to be energized through an autotransformer (for voltage reduction), make sure the common terminal is connected to the earthed pole of the power source.

BEFORE SWITCHING ON THE INSTRUMENT, the protective earth terminals of the instrument must be connected to the protective conductor of the mains power cord. The mains plug shall only be inserted in a socket outlet provided with

protective earth contact. The protection must not be negated by using an extension cord (power cable) without a protective grounding conductor.

Interruption of the protective (grounding) conductor, inside or outside the instrument, or disconnection of the protective earth terminal is likely to make this instrument dangerous. Intentional interruption of the earth ground is prohibited.

Servicing this instrument often requires that you work with the instrument's protective covers removed and with ac power connected. Be very careful; the energy at many points in the instrument may, if contacted, cause personal injury.

With the ac power cable connected, the ac line voltage is present at the terminals of the power line module and at the LINE power switch. Be very careful. Bodily contact with this voltage can be fatal.

CAUTIONS

BEFORE SWITCHING ON THIS INSTRUMENT, make sure instrument's ac input is set to the voltage of the ac power source.

BEFORE SWITCHING ON THIS INSTRUMENT, make sure that all devices connected to the instrument are connected to the protective earth ground.

BEFORE SWITCHING ON THIS INSTRUMENT, make sure the line power (mains) plug is connected to a threeconductor line power outlet that has a protective (earth) ground. (Grounding one conductor of a two-conductor outlet is not sufficient.

BEFORE SWITCHING ON THIS INSTRUMENT, make sure the ac line fuse is of the required current rating and type (normal-blow, time-delay, etc.).

1-16. INSTRUMENTS COVERED BY MANUAL

1-17. Hewlett-Packard instruments carry a serial number (see Figure 1-2) on the back panel. When 1-2 the serial number prefix on the instrument serial number plate of your instrument is the same as one of the prefix

numbers on the inside title page of this manual, the manual applies directly to the instrument. When the instrument serial number prefix is not listed on the inside title page of initial issue, manual change sheets and manual up-dating information is provided. Later editions or revisions to the manual will contain the required change information in Section VII.



Figure 1-2. Instrument Identification

1-18. DESCRIPTION

1-19. The Model 8444A Tracking Generator is designed to complement both Model 8554B and Model 8555A Spectrum Analyzer RF Sections. The Tracking Generator covers the frequency range of 500 kHz to 1250 MHz when used with the 8554B RF Section and from 10 MHz to 1.3 GHz when used with the 8555A RF Section. The Tracking Generator/Spectrum Analyzer functions as a system to perform frequency response measurements. Additionally, the system can be used as a signal generator or sweeper to supply a test signal to other devices. An auxiliary output is provided for precision frequency measurements by an external frequency counter.

1-20. The Tracking Generator converts the first and third local oscillator (LO) signals from the Spectrum Analyzer RF Section, to a signal that tracks the frequency tuning of the RF Section. With the Spectrum Analyzer operating in ZERO SCAN WIDTH, the Tracking Generator is a CW signal generator, tuned to the frequency of the analyzer.

In FULL or PER DIVISION SCAN WIDTH the Tracking Generator functions as a sweep oscillator which tracks the analyzer tuning. Additionally, a

Table 1-1. System Specifications

These system specifications describe the performance available from the spectrum analyzer-tracking generator system in various types of applications. In all cases it is assumed that the spectrum analyzer is equipped with either an 8554B or 8555A Tuning Section, 8552A or 8552B IF Section, 140T or 141T Display Section.

SWEEP FREQUENCY RESPONSE MEASUREMENTS The tracking generator is used as a signal source to measure the frequency response of a device.

Dynamic Range: > 90 dB from spectrum analyzer 1 dB gain compression point to average noise level (approximately -10 dBm to -100 dBm). Spurious responses not displayed.

Gain Compression: For -10 dBm signal level at the input mixer, gain compression < 1 dB.

Average Noise Level: > -102 dBm with 10 kHz IF bandwidth.

Absolute Amplitude Calibration Range:

Spectrum Analyzer: Log: From -122 dBm to +10 dBm, 10 dB/div on a 70 dB display or 2 dB/div on a 16 dB display (8552A has 10 dB/div only).

Linear: From 0.1 pV/div to 100 mV/div (8555A), 20 mV/div (8554B) in a 1, 2 sequence on an 8division display.

Tracking Generator (Drive Level to Test Device): 0 to -10 dBm continuously variable. 0 dBm calibrated to +0.5 dB at 30 MHz.

Frequency Range: 500 kHz to 1250 MHz with 8554B and 10 MHz to 1300 MHz with 8555A.

Scan Width (Determined by Spectrum Analyzer Controls):

Per Division: With 8555A, 16 calibrated scan widths from a 2 kHz/div to 200 MHz/div in a 2, 5, 10 sequence. With 8554B, 15 calibrated scan widths from a 2 kHz/div to 100 MHz/div in 2, 5, 10 sequence.

Full Scan: 0--1250 MHz with 8554B; 0-1300 MHz with 8555A.

Zero Scan: Analyzer is fixed tuned receiver.

Frequency Resolution: 1 kHz.

Stability:

Residual FM (peak to peak):

Tuning Section	Stabilized	Unstabilized
8554B/8555A	200 Hz	10 kHz

Amplitude Accuracy:

System Frequency Response: +1.5 dB.

Tracking Generator Calibration: 0 dBm at 30 MHz to +0.5 dB.

SWEEP/CW GENERATOR

The tracking generator-spectrum analyzer system can be used to supply test signals for other devices as a sweeper.

Frequency: Controlled by spectrum analyzer. Range is 500 kHz to 1250 MHz with the 8554B and 10 MHz to 1300 MHz with the 8555A.

Frequency Accuracy: +10 MHz (8554B), +15 MHz (8555A) using spectrum analyzer tuning dial. Can be substantially improved using external counter output.

Spectral Purity:

Residual FM (peak-to-peak):

Tuning Section	Stabilized	Unstabilized
8554B/8555A	200 Hz	10 kHz

Harmonic Distortion: 25 dB below output level.

Nonharmonic (spurious) Signals: >40 dB below output level.

Flatness: +/- 0.5 dB.

Long Term Stability: Drift typically less than 30 kHz/hour when stabilized after 2-hour warmup.

Sweep Width: 20 kHz to 1250 MHz (8554B) or 1300 MHz (8555A).

Sweep Rates: Selected by Scan Time per Division on spectrum analyzer. 16 internal scan rates from 0.1 msec/div to 10 sec/div in a 1, 2, 5 sequence. Manual Scan is available with the external sweep voltage from the 8444A or by a front panel control of the 8552B IF Section.

PRECISION FREQUENCY MEASUREMENTS

An external counter output is provided on the 8444A for precision frequency measurements. The frequency of unknown signals as well as the frequency of any point on a frequency response curve can be measured. The use of the HP 5300A/5303A Counter is suggested for frequency measurements to 500 MHz and the HP 5245L/5254C Counter for measurements to 1300 MHz.

Frequency Accuracy:

For unknown signals +10 kHz. (Tracking drift typically 5 kHz/10 min after 2-hour warmup.)

For points on frequency response curve. Counter accuracy ±Residual FM.

Counter Mode of Operation:

Manual Scan: Scan determined either by front panel control of 8552B IF Section or by external scan signal provided by the 8444A.

Zero Scan: Analyzer is fixed tuned receiver. Counter reads center frequency to accuracy of tracking drift.

Counter Output Level: 0.1 V rms.

GENERAL SPECIFICATIONS

Temperature Range: Operation, 0 to 55°C, storage -40°C to 75°C.

Power: 115V and 230V, 48 to 440 Hz, 12 watts max.

MANUAL SCAN control on the Tracking Generator allows manual tuning of the Spectrum Analyzer/Tracking Generator System. The amplitude of the Tracking Generator output is adjustable over a 0 to -10 dBm range by a front panel vernier control. The output level is calibrated at 30 MHz to 0 +/- 0.5 dBm and maintained by an automatic level control circuit. Refer to Table 1-1 for system performance specifications.

1-21. 8554L RF SECTION MODIFICATIONS

1-22. Hewlett-Packard Model 8554L Spectrum Analyzer RF Section with serial prefixes 1101A and below require modification for Tracking Generator compatibility. The modification consists of adding two cables to the RF Section. The cables provide front panel access to the first and third LO outputs. The modification kit, HP Part Number 08554-60056, containing all necessary parts and information is available from any Hewlett-Packard Sales and Service Office. (A list of Sales and Service offices is contained in the back of this manual.) Service Note 8554L-6 containing the modification procedure is included with the modification kit. After modification, the Service Note should be filed with the 8554L Service Manual.

1-23. ACCESSORIES SUPPLIED

1-24. Accessories supplied with the Tracking Generator are listed in Table 1-2. RF cables, supplied with the Tracking Generator, allow operation with either the 8554B or 8555A Spectrum Analyzer RF Sections. The power cable, supplied with the instrument, is selected at time of shipment. Cable selection is based on shipping destination. Figure 2-1 illustrates the different power

cable connectors that are currently available.

1-25. OPERATING ACCESSORIES

1-26. In addition to the accessories supplied with the Tracking Generator, a Spectrum Analyzer System is required to complete the Tracking Generator Spectrum Analyzer System. The Tracking Generator is compatible with either the 8554B/8552()/140-series Spectrum Analyzer System or the 8555A/8552()/140-series Spectrum Analyzer System. Refer to paragraph 1-11 for modifications to early model Spectrum Analyzer Systems. For precision frequency measurements a frequency counter is required for use with the Tracking Generator/Spectrum Analyzer System. Operating accessories are listed in Table 1-4.

1-27. WARRANTY

1-28. The Hewlett-Packard Model 8444A Tracking Generator is warranted and certified as indicated on the inner front cover of this manual. For further information contact the nearest Hewlett Packard Sales and Service office; addresses are provided at the back of this manual.

1-29. RECOMMENDED TEST EQUIPMENT

1-30. Table 1-3 lists the test equipment and accessories required to check, adjust, and repair the Tracking Generator. If substitute equipment is used, it must meet the Minimum Specifications listed in Table 1-3.

Table 1-2. Accessories Supplied

HP Part Number	Name	Description
8120-1348*	Line Power Cable	71 feet, 3 wire AC Line Cord
08444-60017	Interconnect Cable	Coaxial cable for interconnection between AUX "A" connector on Display Section and THIRD LO INPUT on Tracking Generator. For use with 8555A Spectrum Analyzer System.
08444-60018	Interconnect Cable	18-inch low leakage coaxial cable with BNC connectors. Three (3) each supplied. Two required for 8555A Spectrum Analyzer System. Three required for 8554B Spectrum Analyzer System. Connects FIRST LO to FIRST LO, THIRD LO to THIRD LO and SCAN OUTPUT to SCAN IN/OUT.

*See paragraph 2-15 and Figure 2-1.

Table 1-3. Test Equipment and Accessories (1 of 3)

Item	Minimum Specifications	Suggested Model	Use*
Spectrum Analyzer System	Frequency Range: 500 kHz – 1.25 GHz Compatible with Tracking Generator (Part of System)	HP 8554B or 8555A/8552B 141T Spectrum Analyzer System	P,A,T
Frequency Comb Generator	Frequency markers spaced 100 MHz apart Frequency Accuracy: $\pm 0.01\%$ Output Amplitude: -30 dBm to 1.5 GHz	HP 8406A Comb Generator	P,T
Spectrum Analyzer System (Test Analyzer)	Frequency Range: 500 kHz – 4 GHz Amplitude Accuracy: ± 1 dB	HP 8553B/8555A/8552B/ 141T Spectrum Analyzer System	P,A,T
Power Meter	Frequency Range: 500kHz – 1.6GHz Accuracy: $\pm 1\%$ Power Range: -20 to $+10$ dBm	HP435A Power Meter with HP 8482A Therm- istor Mount	P,A,T
AC Voltmeter	Frequency Range: 10 Hz to 10 MHz Voltage Range: 1 mV to 300V Calibration: -10 to $+2$ dB, 10 dB between ranges. Accuracy: $\pm 5\%$ at 10 MHz	HP 400E AC Voltmeter	P,A
AC Voltmeter	Voltage Accuracy: $\pm 3\%$ of full scale Voltage Range: 300V full scale Input Impedance: 10 megohms	HP 410C Multifunction Voltmeter	A, T
Frequency Counter	Frequency Range: 500kHz – 1.6GHz Frequency Accuracy: $\pm 0.01\%$	HP 5340A Frequency Counter with HP 5254C Frequency Converter	P,A,T
Test Oscillator	Frequency Range: 10 Hz – 10 MHz Frequency Accuracy: $\pm 3\%$ Output Amplitude: 3 Vrms Output Impedance: 50 ohms	HP 652A Test Oscillator	P,A
HF Signal Generator	Frequency Range: 1 – 50 MHz Output Amplitude: > 0 dBm Frequency Accuracy: $\pm 1\%$ Output Impedance: 50 ohms	HP 606A/B HF Signal Generator	P
VHF Signal Generator	Frequency Range: 50 – 450 MHz Output Amplitude: > 0 dBm Output Impedance: 50 ohms	HP 608E/F VHF Signal Generator	P
UHF Signal Generator	Frequency Range: 450 – 1200 MHz Output Amplitude: 0 dBm Output Impedance: 50 ohms	HP 612A UHF Signal Generator	P
Digital Voltmeter	Voltage Accuracy: $\pm 0.2\%$ Voltage Range: 1 – 30 Vdc Polarity: Automatic Indication	HP 3440A Digital Volt- meter w HP 3443A Plug-in	A,T
*P = Performance Test; A = Adjustments; T = Troubleshooting			

Table 1-3. Test Equipment and Accessories (2 of 3)

Item	Minimum Specifications	Suggested Model	Use*
Variable Voltage Transformer	Voltage Range: 102 – 127 Vac	General Radio W5MT3A or Superior Electric UC1M	A, T
Power Supply Dual Dc	Output Voltage: Variable 0 – 20 Vdc Output Current: 0 – 200 mA Meter Accuracy: $\pm 3\%$ Control: Fine adjustment	HP 6205B Power Supply	A, T
Dc Volt-Ohm-Ammeter	Voltmeter Voltage Range: 1 mV – 50 Vdc Accuracy: $\pm 1\%$ Input Resistance: 10 megohms Ammeter Current Range: 1 mA – 200 mA Accuracy: $\pm 2\%$ Ohmmeter Resistance Range: 1 ohm – 100 megohm Accuracy: $\pm 5\%$ reading at center scale	HP 412A Volt-Ohm Ammeter	A, T
Coaxial Attenuator	Frequency Range: DC – 4 GHz Flatness: ± 0.2 dB	HP 8491A Option 10	A, T
Adapter	BNC Tee	UG-274B/U HP 1250-0781	P,A,T
Adapter	BNC Female to Type N Male	UG-201A/U HP 1250-0067	P,A,T
Cable Assembly	Coaxial cable with Male BNC connectors, 48 inches long	HP 10503A	P,A,T
Cable Assembly	Coaxial cable terminated with BNC Male connector and with probe and alligator clip	HP 10501A	A, T
Cable Assembly	Coaxial cable terminated with BNC Male connector and alligator clips	HP 10501A	A, T
Cable Assembly	Coaxial cable terminated with dual banana plug and probe with alligator clip	HP 11003A	A, T
Cable Assembly	Coaxial cable with dual banana plug and Male BNC connector terminations	HP 11001A	A, T
Cable Assembly	SMA Male to BNC Male	HP 08555-60076	A, T
Cable Assembly	Selectro Female to BNC Male Test Cable, 36 inches long	HP 11592-60001	A, T
Cable Assembly	Selectro Female to Selectro Male Test Cable, 8 inches long	HP 11592-60003	A, T
Adapter	BNC Jack to BNC Jack	UG-914A/U HP 1250-0080	A, T
*P = Performance Test; A = Adjustments; T = Troubleshooting			

Table 1-3. Test Equipment and Accessories (3 of 3)

Item	Minimum Specifications	Suggested Model	Use*
Wrench	Open-end, 5/16-inch	HP 8720-0030	A,T
Wrench	No. 10 Allen Driver	HP 5020-0291	A,T
Test Lead	Test lead with alligator clips	common	A,T
Resistor	100K ohm, 5%, 1 watt	HP 0757-0367 (1%)	A,T
Wrench	Open-end, 15/64-inch	HP 8710-0946	T
Low-pass Filter	700 MHz Cut-off	HP 360A	T
*P = Performance Test; A = Adjustments; T = Troubleshooting			

Table 1-4. Operating Accessories

Model Number	Name	Description
HP 8554B	RF Section	Spectrum Analyzer RF Section with frequency range of 500 kHz to 1250 MHz.
HP 8555A	RF Section	Spectrum Analyzer RF Section with frequency range of .01 to 18 GHz. When used with Tracking Generator, covers frequency range of 10 to 1300 MHz.
HP 140T	Display Section	Spectrum Analyzer Display Section compatible with Tracking Generator.
HP 141T	Display Section	Spectrum Analyzer Display Section with storage CRT display capability. Compatible with Tracking Generator.
HP 8552A	IF Section	Spectrum Analyzer IF Section compatible with Tracking Generator, 10 dB per division log range.
HP 8552B	IF Section	Spectrum Analyzer IF Section compatible with Tracking Generator, 2 dB per division log range.
HP 5300A/ 5303A	Frequency Counter	For precision frequency measurements to 500 MHz.
HP 5245L/ 5254C	Frequency Counter	For precision frequency measurements over frequency range of 0 to 50 MHz and 150 to 3000 MHz.
HP 5060-8543	Joining Bracket Kit	Hardware and parts for strapping Tracking Generator to Spectrum Analyzer. Provides a common ground and secure mounting.
HP 8120-1575	Accessory Power Cord	For accessory instrument operation off of line input to Tracking Generator. Plugs mate with accessory outlet connector and line input connector on HP 5060-1189 power line module.
HP 8120-1576	Accessory Power Cord	For accessory instrument operation off of line input to Tracking Generator. Plugs mate with accessory outlet connector and line input connector HP 1251-0148 (old type).
HP 5060-8739	Rack Mounting Kit	To install instrument in 19-inch rack.

SECTION II INSTALLATION

2-1. INITIAL INSPECTION

2-2. Mechanical Check

2-3. Check the shipping carton for evidence of damage immediately after receipt. If there is any visible damage to the carton, request the carrier's agent be present when the instrument is unpacked. Inspect the instrument for physical damage such as bent or broken parts and dents or scratches. If damage is found refer to paragraph 2-6 for recommended claim procedures. If the instrument appears to be undamaged, perform the electrical check (see paragraph 2-4). The packaging material should be retained for possible future use.

2-4. Electrical Check

2-5. The electrical check consists of following the performance test procedures listed in Section IV. These procedures allow the operator to determine that the instrument is, or is not, operating within the specifications listed in Table 1-1. The initial performance and accuracy of the instrument are certified as stated on the inside front cover of this manual. If the instrument does not operate as specified, refer to paragraph 2-6 for the recommended claim procedure.

2-6. CLAIMS FOR DAMAGE

2-7. If physical damage is found when the instrument is unpacked, notify the carrier and the nearest Hewlett-Packard Sales and Service office immediately. The Sales and Service office will arrange for repair or replacement without waiting for a claim to be settled with the carrier.

2-8. The warranty statement for the instrument is on the inside front cover of this manual. Contact the nearest Sales and Service office for information about warranty claims.

2-9. PREPARATION FOR USE

CAUTION

Before applying power, check the power selector switch on the Tracking Generator input power module (rear panel) for proper position (115 or 230 volts).

2-10. Power Requirements

2-11. The Tracking Generator can be operated from a 48 to 440-hertz input line that supplies either 115 or 230-volt (+10% in each case) power. Consumed power is normally less than 15 watts.

2-12. The 115/230 power selector switch on the rear panel line power module must be set to agree with the available line voltage. The selector switch is located below the fuse holder and fuse extractor lever. An arrow on the selector switch points to callouts listing the line input voltage and fuse amperage rating. To change the position of the selector switch it is necessary to remove the power cable, slide the protective cover to the left and lift the fuse extractor before the switch can be changed. With the fuse extractor extended, press down and toward the desired direction. Replace fuse with a fuse of the amperage rating for the selected position. See Section VI for replacement HP Part Numbers. The instrument is normally shipped with fuse installed for 115-volt operation.

2-13. Power Cable

2-14. To protect operating personnel, the National Electrical Manufacturers Association (NEMA) and the International Electrotechnical Commission (IEC) recommends that the instrument panel and cabinet be grounded. The Tracking Generator is equipped with a three-conductor power cable; the third conductor is the ground conductor and when the cable is plugged into an appropriate receptacle, the instrument is grounded. To preserve the protection feature when operating the instrument from a two-contact outlet, use a three-prong to two-prong adapter and connect the green or green/yellow lead on the adapter to ground.

2-15. Power cables are selected for shipment with each instrument; with a line connector plug to match the standard power cord for the country of destination on the purchase order. A label indicating the power cable inside is affixed to the packing case. Figure 2-1 indicates the connector plugs and the HP part numbers for the various available power cables and plugs.

2-16. OPERATING ENVIRONMENT

2-17. The Tracking Generator does not require forced air cooling when operating at temperatures from 0 to 55°C (32 to 131°F). When operating the instrument, choose a location which will provide at

least three inches of clearance around the rear and both sides. Normal air circulation will maintain a reasonable temperature within the instrument.

required, return address, instrument model number and full serial number. Mark the container FRAGILE to assure careful handling.

2-18. INSTALLATION CONNECTIONS

2-25. In any correspondence refer to the instrument by model number and full serial number.

2-19. A rack mounting kit is supplied for rack installation. Additionally, a joining bracket kit (accessory) can be provided to secure the Tracking Generator to the Spectrum Analyzer. Installation instructions are supplied with both joining bracket and rack mounting kits.

2-26. Other Packaging Materials

2-20. Electrical connections are provided by three coaxial cables and two line power cords. Coaxial cables connect Spectrum Analyzer FIRST LO OUTPUT to Tracking Generator FIRST LO INPUT, THIRD LO OUTPUT to THIRD LO INPUT and SCAN OUTPUT to SCAN IN/OUT. Double shielded coaxial cables are provided for connection between local oscillator input and output connectors. Refer to Table 1-2 for description and HP part number of cables supplied with the Tracking Generator.

2-27. The following general instructions should be followed when repackaging with commercially available materials:

2-21. STORAGE AND SHIPMENT

a. Wrap the instrument in heavy paper or plastic. (If shipping to a Hewlett-Packard Service office or center attach a tag indicating the type of service required, return address, model number and full serial number.)

2-22. Original Packaging

b. Use a strong shipping container. A double-wall carton made of 350 pound test material is adequate.

2-23. The same containers and materials used in factory packaging can be obtained through the Hewlett-Packard Sales and Service offices listed at the rear of this manual.

c. Use enough shock-absorbing material (three to four inch layer) around all sides of the instrument to provide firm cushion and prevent movement inside the container. Protect the control panel with cardboard.

2-24. If the instrument is being returned to Hewlett-Packard for servicing, attach a tag indicating service

d. Seal the shipping container securely.

e. Mark the shipping container FRAGILE to assure careful handling.

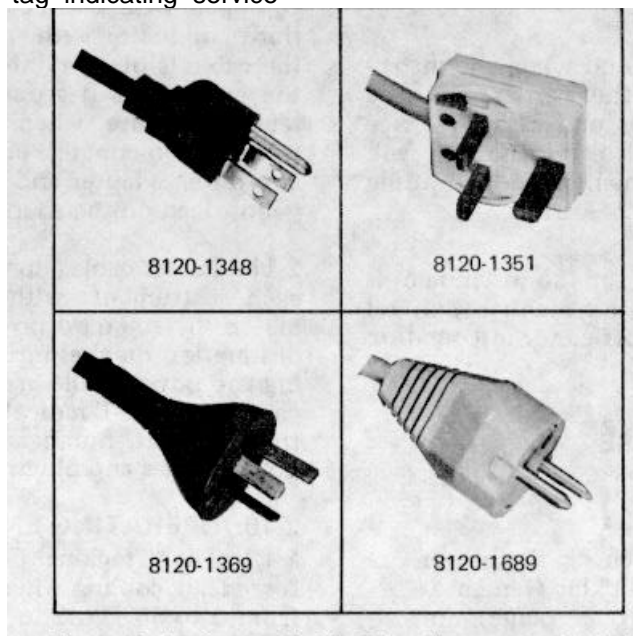

Figure 2-1. Power Cable Line Connector Labels

SECTION III OPERATION

3-1. INTRODUCTION

3-2. This section provides complete operation instructions for the HP Model 8444A Tracking Generator. Front and rear panel controls, connectors and indicators for the Tracking Generator are identified and described in Figures 3-1 and 3-2. Operational connections and adjustments for the Tracking Generator and an 8554B Spectrum Analyzer System are detailed in Figure 3-3. Operational connections and adjustments for the Tracking Generator and an 8555A Spectrum Analyzer System are detailed in Figure 3-4. Additional operating information is contained in Figures 3-5 through 3-10.

3-3. PANEL FEATURES

3-4. Front and rear panel features of the Tracking Generator are described in Figures 3-1 and 3-2. Front and rear panel views of the Tracking Generator connected to the HP 8554B/8552/141T Spectrum Analyzer are shown in Figure 3-3. Front and rear panel views of the Tracking Generator connected to the HP 8555A/8552/141T Spectrum Analyzer are shown in Figure 3-4. For a detailed description of the Spectrum Analyzer controls, connectors and indicators refer to the appropriate operating and service manuals for those instruments. Interconnection wiring between the Tracking Generator and the Spectrum Analyzer is contained in Section VIII (Service Sheet 1) of this manual.

3-5. OPERATOR'S CHECKS

3-6. Upon receipt of the instrument, or when the Tracking Generator is to be used with a different Spectrum Analyzer, perform the operational adjustment procedures listed in Figure 3-3 or 3-4.

3-7. OPERATING INSTRUCTIONS

3-8. General operating instructions are contained in Figures 3-3 and 3-4. These instructions will familiarize the operator with basic operating functions of the Tracking Generator in use with Spectrum Analyzers. Additional operating techniques and information is contained in Figures 3-5 through 3-10.

3-9. CONTROLS, INDICATORS AND CONNECTORS

3-10. Front and rear panel controls, indicators and connectors are identified and briefly described in Figures 3-1 and 3-2. Operational adjustment procedures are given in Figures 3-3 and 3-4. Additional information, to assist the user during instrument operation, is given in the following paragraphs.

3-11. OPERATING TECHNIQUES

3-12. The following information is provided to acquaint the user with Tracking Generator/ Spectrum Analyzer operation. When a device is placed in the signal path between the Tracking Generator and the Spectrum Analyzer, the analyzer detects and displays the frequency response of the device under test. The Spectrum Analyzer tuning and scan width settings determine the Tracking Generator output frequency and the resultant CRT display. The type of device, control settings, and typical display is provided for each of the following measurements.

- a. Crystal Filter Measurement, Para. 3-13.
- b. Bandpass Filter Measurement, Para. 3-15.
- c. Low-Pass Filter Measurement, Para. 3-17.
- d. Swept Return Loss Measurement, , Para. 3-19.
- e. Amplifier Gain and Bandwidth Measurement, Para. 3-21.
- f. Precision Frequency Measurement, Para. 3-23.

FRONT PANEL

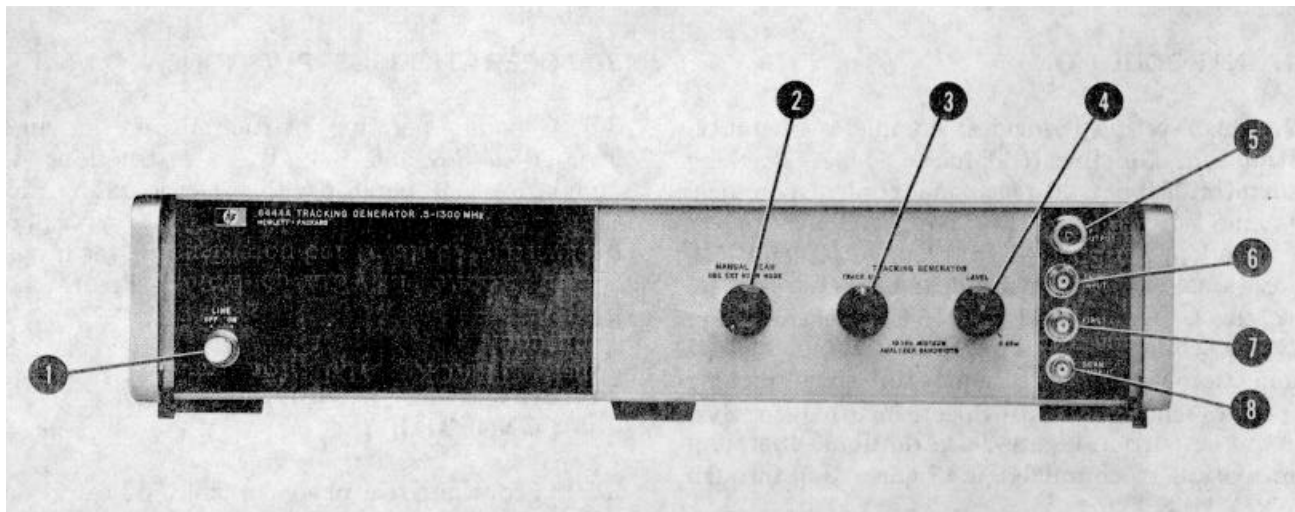

1. **LINE - ON/OFF.** Controls primary power to Tracking Generator. Light glows when switch is energized. Type A1H bulb. For access to bulb, switch to OFF and pull button straight out.
2. **MANUAL SCAN.** Provides manual tuning of Spectrum Analyzer. Controls voltage level at SCAN OUTPUT (8) below. Scan trace on CRT determined by position of MANUAL SCAN control. For MANUAL SCAN operation, connect cable between Tracking Generator SCAN OUTPUT and Spectrum Analyzer SCAN IN/OUT. Set Spectrum Analyzer SCAN MODE switch to EXT. Vary MANUAL SCAN control to tune analyzer through selected SCAN WIDTH.
3. **TRACK ADJ.** Adjusts frequency of 1.55 GHz oscillator in Tracking Generator so that the RF OUTPUT (5) tracks the frequency tuning of the Spectrum Analyzer. Control adjusted for maximum amplitude indication of trace on CRT display. Ten turn control provides adjustment of frequency over a range of approximately 4 MHz.
4. **LEVEL.** Adjusts Tracking Generator RF OUTPUT (5) level over range of 0 to -10 dBm. Level calibrated for 0 dBm at 30 MHz with accuracy of +0.5 dB. Set LEVEL control to 0 dBm for calibrated CRT display on Spectrum Analyzer.
5. **RF OUTPUT.** Type N Connector - Tracking Generator RF output connector. Frequency adjusted to track tuning of Spectrum Analyzer by TRACK ADJ (3). Output level adjusted by LEVEL (4).
6. **THIRD LO INPUT.** Type BNC connector Input for Spectrum Analyzer third LO (500 MHz). Normally used with 8554B RF Section. Parallel with rear panel THIRD LO INPUT which is normally used with 8555A RF Section.
7. **FIRST LO INPUT.** Type BNC connector-Input for Spectrum Analyzer first LO (2.05 - 3.3 GHz with 8554L RF Section) - (2.05 - 4.1 GHz with 8555A RF Section).
8. **SCAN OUTPUT.** Type BNC connector. Manual tune voltage to Spectrum Analyzer (0 to 10 Vdc). Voltage level controlled by position of MANUAL SCAN (2).

Figure 3-1. Model 8444A Tracking Generator Front Panel Controls, Indicators and Connectors

REAR PANEL

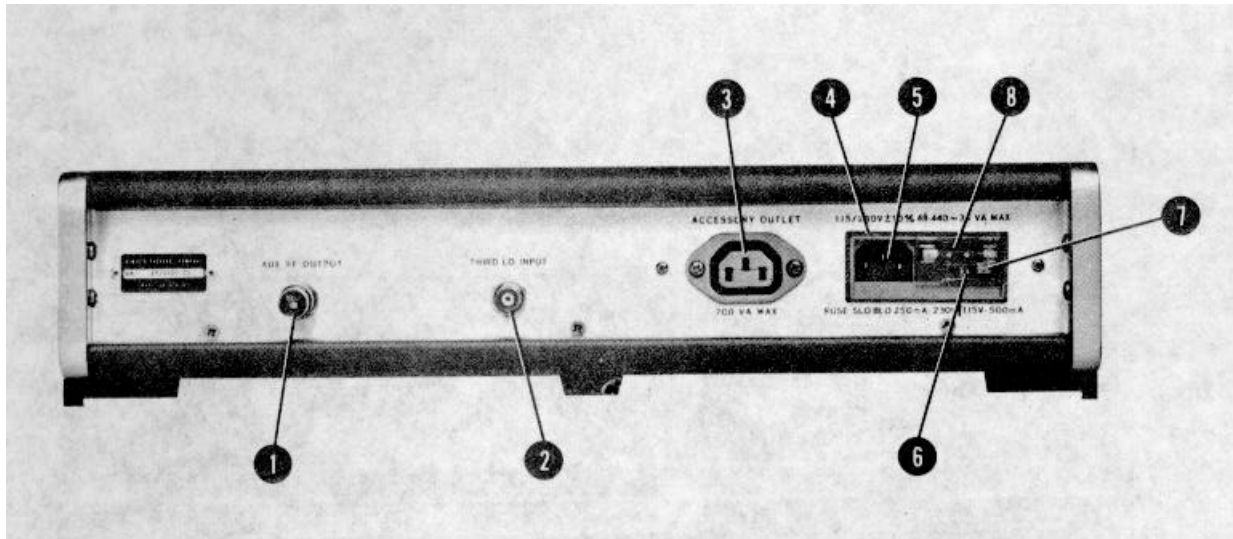

1. **AUX RF OUTPUT.** Type BNC connector Tracking Generator auxiliary RF output. Same frequency as signal out front panel RF OUTPUT connector. For use with external frequency counter during precision frequency measurements. Terminate in 50 ohms.
2. **THIRD LO INPUT.** Type BNC connector Input for Spectrum Analyzer third LO (500 MHz). Normally used with 8555A RF Section. Parallel with front panel THIRD LO INPUT which is normally used with 8554B RF Section.
3. **ACCESSORY OUTLET.** Line power outlet. Connected to power line module input. Provides ac outlet for use by accessory equipment.
4. Line power module. 115/230V, 48-440 Hz.
5. Line input. Connects to external ac power source. Supplies ac power to ACCESSORY OUTLET when connected to external power source.
6. 115/230V Switch. Line voltage slide switch; controls power supply input connections. Check that switch is set for nominal voltage of ac line. To change setting; remove power cord from line input (5) , slide protective cover aside, extract fuse with FUSE PULL (7) and slide switch to desired position. Replace fuse with a fuse of the value indicated for the desired switch position.
7. Fuse extractor and switch lock. Prevents line switch from being actuated until fuse is extracted.
8. Line input fuse. Rating of fuse to be used is marked near line voltage slide switch setting corresponding to nominal ac supply voltage.

Note

See Table 14 for HP part numbers of interconnecting power cords.

Figure 3-2. Model 8444A Tracking Generator Rear Panel Controls and Connectors

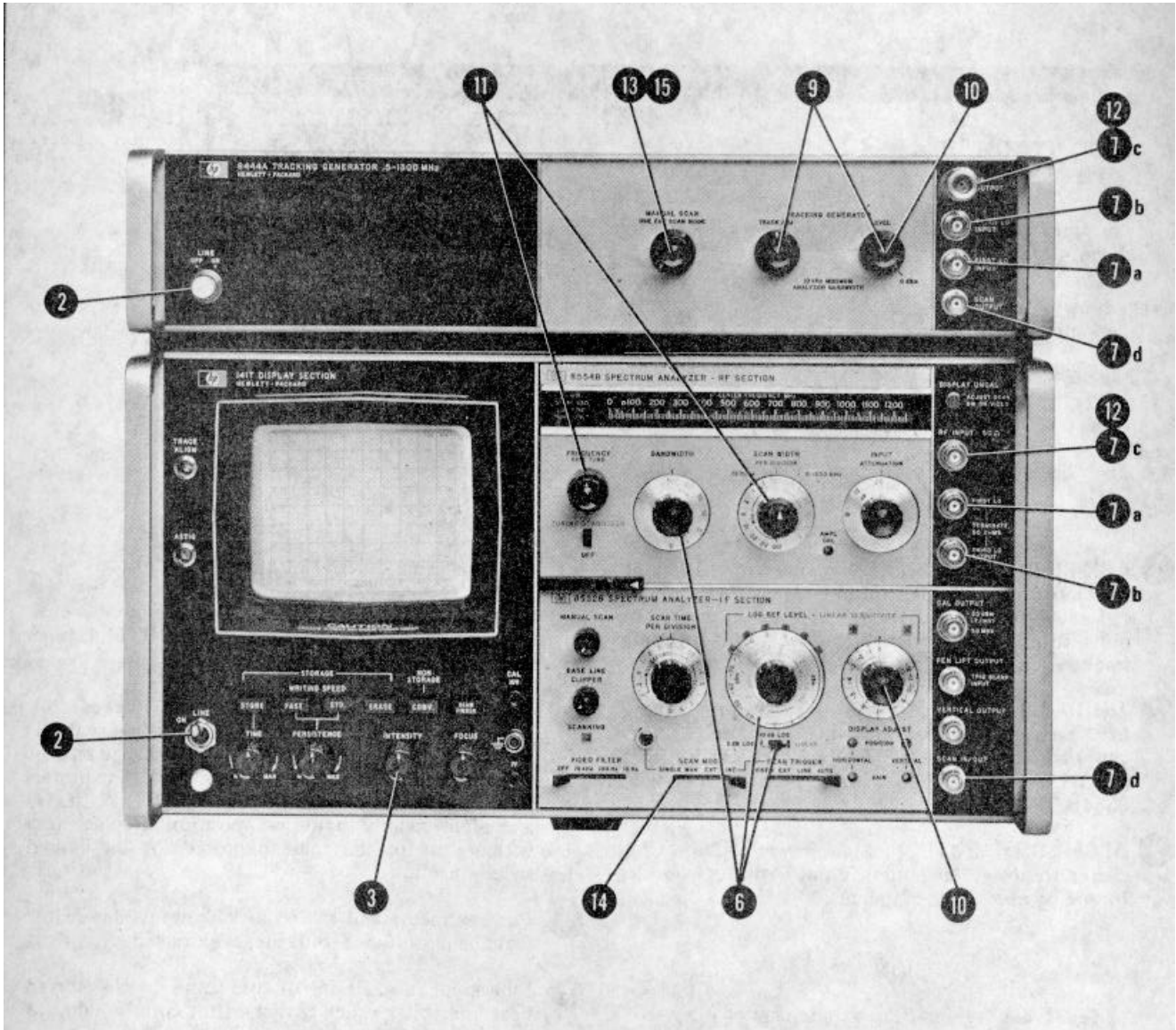

Figure 3-3. Tracking Generator Operation with 8554B Spectrum Analyzer (1 of 2)-,

**OPERATING PROCEDURE
WITH AN 8554B**

- | | |
|---|---|
| <ol style="list-style-type: none"> 1. Check that the 115/230V switch is set to correspond with the available line voltage. Refer to Figure 3-2, steps 4 through 8, for switch and fuse information. 2. Apply power to Tracking Generator and Spectrum Analyzer. 3. Turn Spectrum Analyzer INTENSITY control fully CCW. 4. Allow instruments to warm up for at least 30 minutes. 5. Perform Spectrum Analyzer "Calibration Procedure". Refer to 8554B RF Section Operating Manual. 6. Set Spectrum Analyzer LOG/LINEAR control to LOG, LOG REF LEVEL to 0 dBm, and BANDWIDTH to 300 kHz. 7. Make the following interconnections between Tracking Generator and Spectrum Analyzer: <ol style="list-style-type: none"> a. FIRST LO INPUT to FIRST LO OUTPUT. b. THIRD LO INPUT to THIRD LO OUTPUT. c. RF OUTPUT to RF INPUT. d. SCAN OUTPUT to SCAN IN/OUT. 8. Check that the Spectrum Analyzer controls are set as follows:
INTENSITY 12 o'clock (approx.)
FREQUENCY 30 MHz
BANDWIDTH 300 kHz
SCAN WIDTH PER DIVISION 50 kHz
INPUT ATTENUATION 10 dB
TUNING STABILIZER On
BASE LINE CLIPPER CCW
SCAN TIME PER DIVISION 5 MILLISECONDS

 LOG/LINEAR LOG | <ol style="list-style-type: none"> LOG REF LEVEL 0 dBm LOG REF LEVEL Vernier 0 VIDEO FILTER OFF SCAN MODE INT SCAN TRIGGER LINE 9. Set Tracking Generator LEVEL control to 0 dBm and adjust TRACK ADJ for maximum signal amplitude indication on CRT display. 10. Adjust Spectrum Analyzer Vernier control or Tracking Generator LEVEL control to position signal on CRT LOG REF level graticule line. (System calibrated at 30 MHz with an amplitude accuracy of +/- 0.5 dB.) 11. Set Spectrum Analyzer to scan desired frequency range. (FREQUENCY control adjusted to center of frequency of interest, SCAN WIDTH set for desired coverage.) 12. Insert device to be tested between Tracking Generator RF OUTPUT and Spectrum Analyzer RF INPUT. 13. Rotate Tracking Generator MANUAL SCAN control fully counterclockwise. 14. Set Spectrum Analyzer SCAN MODE switch to EXT. 15. Rotate Tracking Generator MANUAL SCAN control clockwise to tune system through selected frequency range. 16. For automatic scanning, set SCAN MODE switch to INT and SCAN TIME PER DIVISION to desired scan time. |
|---|---|

Figure 3-3. Tracking Generator Operation with 8554B Spectrum Analyzer (2 of 2)

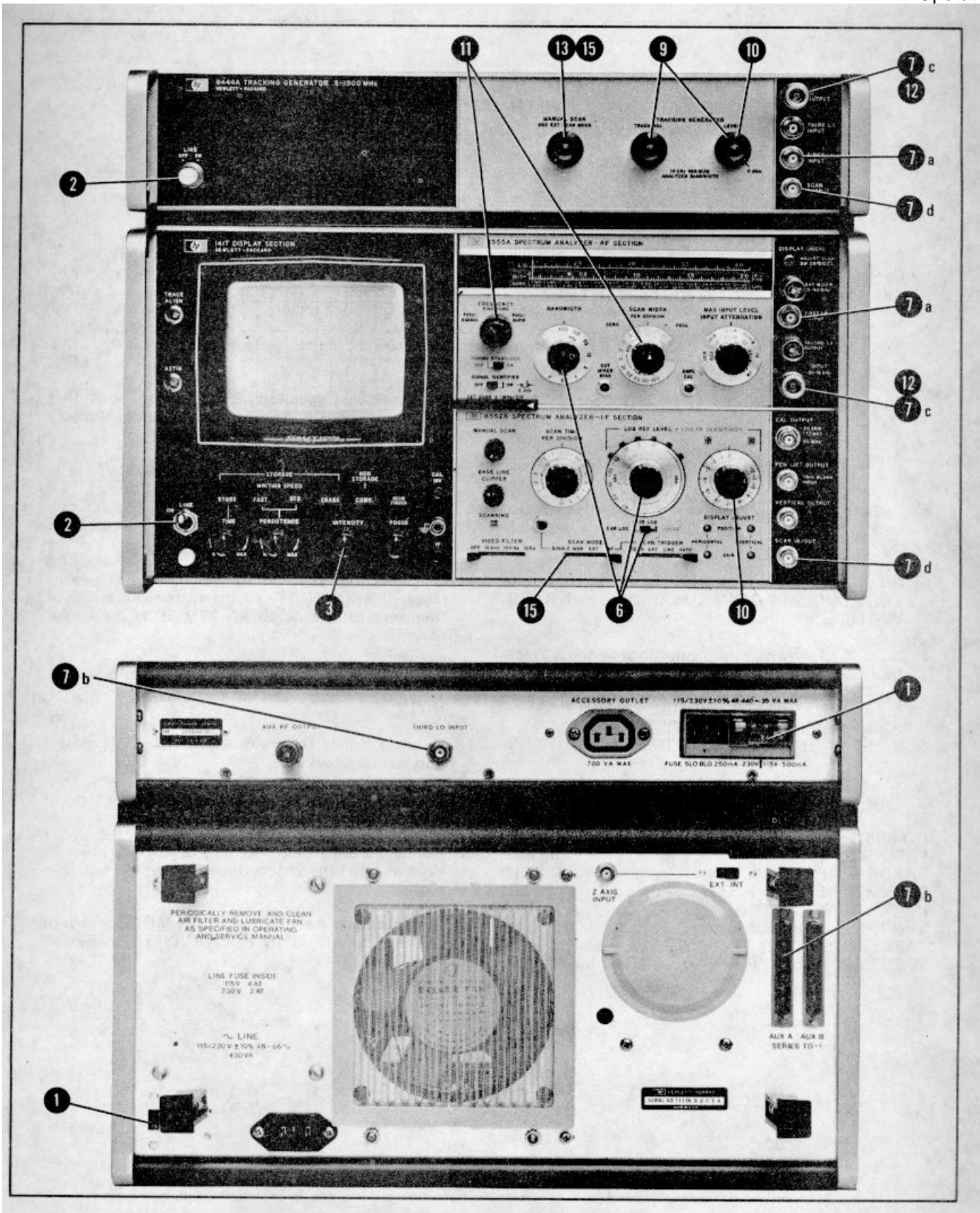

Figure 3-4. Tracking Generator Operation with 8555A Spectrum Analyzer (1 of 2)

**OPERATING PROCEDURE
WITH AN 8555A**

- | | | | | | | | | | | | | | | | | | | | | | | | | | | | | | | | | | |
|--|----------------------|----------------------|------------|--------------------|-----------------|--------|-----------------|---------|-------------------------------|---------|-------------------------|-------|-------------------------|----|-------------------------|-----|-------------------------|-----|------------------------------|-----------------|---|------------------|-----|---------------------|-------|-----------------------------|---|--------------------|-----|-----------------|-----|--------------------|--------------|
| <ol style="list-style-type: none"> 1. Check that the 115/230 switch is set to correspond with the available line voltage. Refer to Figure 3-2, steps 4 through 8, for switch and fuse information. 2. Apply power to Tracking Generator and Spectrum Analyzer. 3. Turn Spectrum Analyzer INTENSITY control fully CCW. 4. Allow instruments to warm up for at least 30 minutes. 5. Perform Spectrum Analyzer Operational Adjustments (30 MHz Calibration). Refer to 8555A RF Section Operating and Service Manual. 6. Set Spectrum Analyzer LOG/LINEAR control to LOG, LOG REF LEVEL to 0 dBm, and BANDWIDTH to 300 kHz. 7. Make the following interconnections between Tracking Generator and Spectrum Analyzer: <ol style="list-style-type: none"> a. FIRST LO INPUT to FIRST LO OUTPUT. b. THIRD LO INPUT to THIRD LO OUTPUT (rear panel connections). c. RF OUTPUT to INPUT. d. SCAN OUTPUT to SCAN IN/OUT. 8. Check that the Spectrum Analyzer controls are set as follows: <table border="0" style="margin-left: 20px;"> <tr> <td>INTENSITY</td> <td>12 o'clock (approx.)</td> </tr> <tr> <td>BAND</td> <td>n=l- (2.05 GHz IF)</td> </tr> <tr> <td>FREQUENCY</td> <td>30 MHz</td> </tr> <tr> <td>BANDWIDTH</td> <td>300 kHz</td> </tr> <tr> <td>SCAN WIDTH PER DIVISION</td> <td>100 kHz</td> </tr> <tr> <td>INPUT ATTENUATION</td> <td>20 dB</td> </tr> <tr> <td>TUNING STABILIZER</td> <td>ON</td> </tr> <tr> <td>SIGNAL IDENTIFIER</td> <td>OFF</td> </tr> <tr> <td>BASE LINE CLIPPER</td> <td>CCW</td> </tr> <tr> <td>SCAN TIME PER DIVISION</td> <td>10 MILLISECONDS</td> </tr> </table> | INTENSITY | 12 o'clock (approx.) | BAND | n=l- (2.05 GHz IF) | FREQUENCY | 30 MHz | BANDWIDTH | 300 kHz | SCAN WIDTH PER DIVISION | 100 kHz | INPUT ATTENUATION | 20 dB | TUNING STABILIZER | ON | SIGNAL IDENTIFIER | OFF | BASE LINE CLIPPER | CCW | SCAN TIME PER DIVISION | 10 MILLISECONDS | <table border="0" style="margin-left: 20px;"> <tr> <td>LOG/LINEAR</td> <td>LOG</td> </tr> <tr> <td>LOG REF LEVEL</td> <td>0 dBm</td> </tr> <tr> <td>LOG REF LEVEL Vernier</td> <td>0</td> </tr> <tr> <td>VIDEO FILTER</td> <td>OFF</td> </tr> <tr> <td>SCAN MODE</td> <td>INT</td> </tr> <tr> <td>SCAN TRIGGER</td> <td>LINE or AUTO</td> </tr> </table> <ol style="list-style-type: none"> 9. Set Tracking Generator LEVEL control to 0 dBm and adjust TRACK ADJ for maximum signal amplitude indication on CRT display. 10. Adjust Spectrum Analyzer Vernier control or Tracking Generator LEVEL control to position signal on CRT LOG REF level graticule line. (System calibrated at 30 MHz with an amplitude accuracy of 10.5 dB.) 11. Set Spectrum Analyzer to scan desired frequency range. (FREQUENCY control adjusted to center of frequency of interest, SCAN WIDTH set for desired coverage.) 12. Insert device to be tested between Tracking Generator RF OUTPUT and Spectrum Analyzer RF INPUT. 13. Rotate Tracking Generator MANUAL SCAN control fully counterclockwise. 14. Set Spectrum Analyzer SCAN MODE switch to EXT. 15. Rotate Tracking Generator MANUAL SCAN control clockwise to tune system through selected frequency range. 16. For automatic scanning, set SCAN MODE switch to INT and SCAN TIME PER DIVISION to desired scan time. | LOG/LINEAR | LOG | LOG REF LEVEL | 0 dBm | LOG REF LEVEL Vernier | 0 | VIDEO FILTER | OFF | SCAN MODE | INT | SCAN TRIGGER | LINE or AUTO |
| INTENSITY | 12 o'clock (approx.) | | | | | | | | | | | | | | | | | | | | | | | | | | | | | | | | |
| BAND | n=l- (2.05 GHz IF) | | | | | | | | | | | | | | | | | | | | | | | | | | | | | | | | |
| FREQUENCY | 30 MHz | | | | | | | | | | | | | | | | | | | | | | | | | | | | | | | | |
| BANDWIDTH | 300 kHz | | | | | | | | | | | | | | | | | | | | | | | | | | | | | | | | |
| SCAN WIDTH PER DIVISION | 100 kHz | | | | | | | | | | | | | | | | | | | | | | | | | | | | | | | | |
| INPUT ATTENUATION | 20 dB | | | | | | | | | | | | | | | | | | | | | | | | | | | | | | | | |
| TUNING STABILIZER | ON | | | | | | | | | | | | | | | | | | | | | | | | | | | | | | | | |
| SIGNAL IDENTIFIER | OFF | | | | | | | | | | | | | | | | | | | | | | | | | | | | | | | | |
| BASE LINE CLIPPER | CCW | | | | | | | | | | | | | | | | | | | | | | | | | | | | | | | | |
| SCAN TIME PER DIVISION | 10 MILLISECONDS | | | | | | | | | | | | | | | | | | | | | | | | | | | | | | | | |
| LOG/LINEAR | LOG | | | | | | | | | | | | | | | | | | | | | | | | | | | | | | | | |
| LOG REF LEVEL | 0 dBm | | | | | | | | | | | | | | | | | | | | | | | | | | | | | | | | |
| LOG REF LEVEL Vernier | 0 | | | | | | | | | | | | | | | | | | | | | | | | | | | | | | | | |
| VIDEO FILTER | OFF | | | | | | | | | | | | | | | | | | | | | | | | | | | | | | | | |
| SCAN MODE | INT | | | | | | | | | | | | | | | | | | | | | | | | | | | | | | | | |
| SCAN TRIGGER | LINE or AUTO | | | | | | | | | | | | | | | | | | | | | | | | | | | | | | | | |

Figure 3-4. Tracking Generator Operation with 8555A Spectrum Analyzer (2 of 2)

3-13. Crystal Filter Measurement

3-14. Figure 3-5 illustrates the CRT display for a 20 MHz crystal filter. Filter characteristics: 2-kHz passband with bandwidth at the 60-dB points less than 10 kHz.

a. Spectrum Analyzer (8555A) control settings:

FREQUENCY 20 MHz
 BANDWIDTH 3 kHz
 SCAN WIDTH PER DIVISION 5 kHz
 INPUT ATTENUATION 10 dB
 SCAN TIME PER DIVISION 20 MILLISECONDS
 LOG REF LEVEL 0dBm
 VIDEO FILTER 100 Hz
 SCAN MODEINT
 SCAN TRIGGER AUTO
 LOG/LINEAR LOG

b. Tracking Generator control settings:

TRACK ADJ Peak
 LEVEL 0dBm

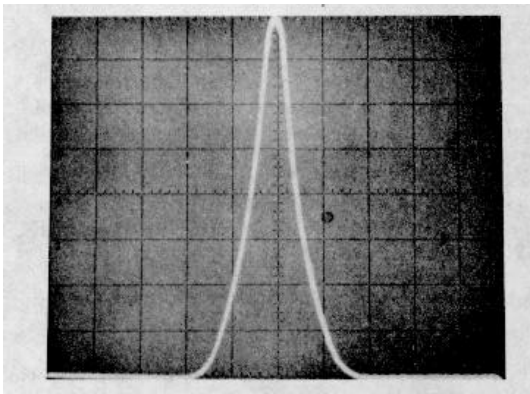

Figure 3-5. 20 MHz Crystal Filter CRT Display

3-15. Bandpass Filter Measurement

3-16. Figure 3-6 illustrates the CRT display for a 50 MHz bandpass filter. Filter characteristics: 50 MHz, 4-pole bandpass filter; adjusted for bandwidth of approximately 5 MHz at the 3 dB points. Bandwidth at 60 dB points is approximately 32 MHz.

a. Spectrum Analyzer (8555A) control settings:

FREQUENCY 50 MHz
 BANDWIDTH 10 kHz
 SCAN WIDTH PER DIVISION 5 MHz
 INPUT ATTENUATION 10 dB

SCAN TIME PER DIVISION 0.5 SECONDS
 LOG REF LEVEL 0 dBm
 VIDEO FILTER 10 Hz
 SCAN MODEINT
 SCAN TRIGGERAUTO
 LOG/LINEAR LOG

b. Tracking Generator control settings:

TRACK ADJ Peak
 LEVEL 0 dBm

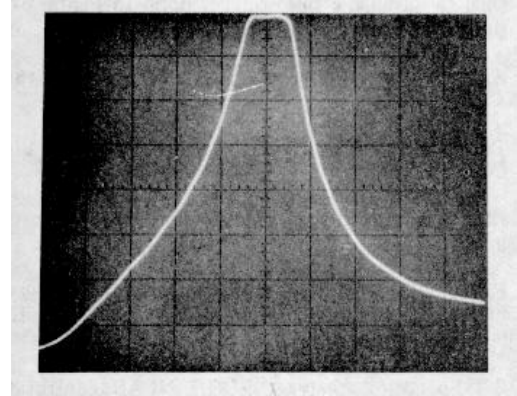

Figure 3-6. 50 MHz Bandpass Filter CRT Display

3-17. Low-Pass Filter Measurement

3-18. Figure 3-7 illustrates the CRT display for a 23 MHz low-pass filter. Filter characteristics: 3 dB point at approximately 23 MHz, 60 dB point at approximately 42 MHz.

a. Spectrum Analyzer (8555A) control settings:

FREQUENCY 25 MHz
 SCAN WIDTH PER DIVISION 5 MHz
 BANDWIDTH100 kHz
 INPUT ATTENUATION 10 dB
 SCAN TIME PER DIVISION 0.1 SECONDS
 LOG/LINEAR LOG
 LOG REF LEVEL(+) 10 dBm
 LOG REF LEVEL Vernier-3 dB
 VIDEO FILTER 10 Hz
 SCAN MODEINT
 SCAN TRIGGERAUTO

b. Tracking Generator control settings:

TRACK ADJ Peak
 LEVEL 0dBm

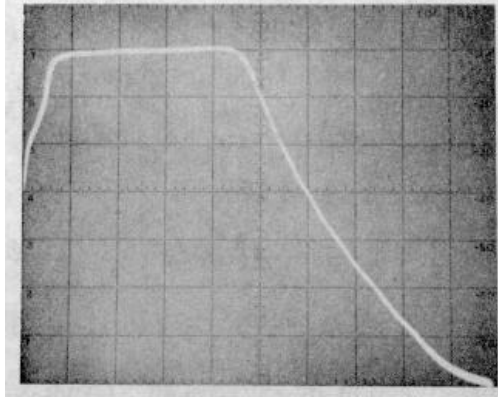

Figure 3-7. 23 MHz Low-Pass Filter CRT Display

3-19. Swept Return Loss Measurement

3-20. Figure 3-8 illustrates the CRT display for a swept return loss or reflection coefficient measurement. A directional bridge (HP 8721A) was used to separate the incident from the reflected signal. The filter under test is the same 23-MHz Low-Pass (paragraph 3-18). Control settings same as paragraph 3-18 except analyzer gain adjusted so that the top graticule line represents 0 dB return loss or total reflection (e.g. a short or open circuit). Return loss is greater than 15 dB ($p0.18$, SWR 1.44) over the filter range of 0 to 23 MHz.

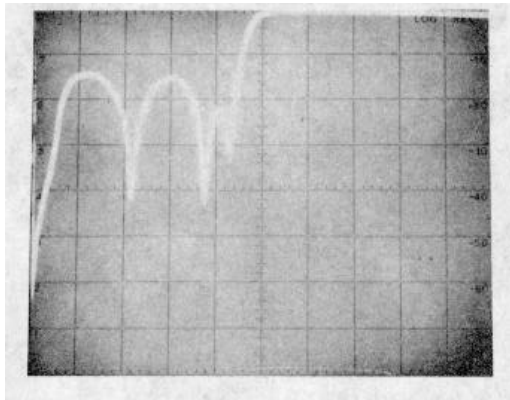

Figure 3-8. Swept Return Loss Measurement
CR T Display

3-21. Amplifier Gain and Bandwidth Measurement

3-22. Figure 3-9 illustrates the CRT display for a .1 to 400 MHz amplifier with gain of approximately 19 dB. A reference level is first established by connecting the Tracking Generator output to the Spectrum Analyzer (through a 30 dB attenuator) and scanning over the range of interest. The amplifier is then connected between the Tracking Generator and the Spectrum Analyzer and the same

frequency range scanned. The Spectrum Analyzer (8554B) set to full scan (0-1250) provides a CRT display indication as follows: 3-dB bandwidth approximately 500 MHz (level at +1 graticule line) and zero gain point of approximately 1025 MHz.

- a. 30 dB Coaxial Attenuator installed at Tracking Generator RF OUTPUT.
- b. Spectrum Analyzer(8554B) control settings:

BANDWIDTH300 kHz
 SCAN WIDTH 0--1250 MHz
 INPUT ATTENUATION 10 dB
 SCAN TIME PER DIVISION 10 MILLISECONDS
 LOG/LINEARLOG
 LOG REF LEVEL +10 dBm
 VIDEO FILTER OFF
 SCAN MODEINT
 SCAN TRIGGERAUTO

- c. Tracking Generator control settings:

TRACK ADJ..... Peak
 LEVEL 0 dBm

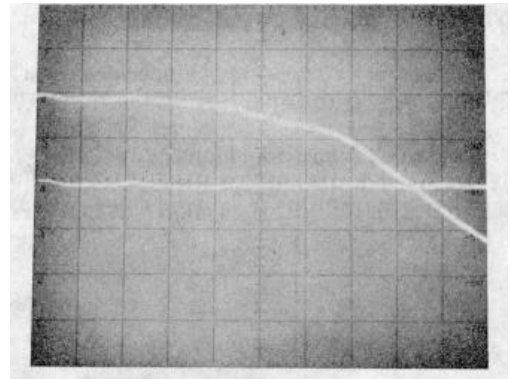

Figure 3-9. Amplifier Gain and Bandwidth
CRT Display

3-23. Precision Frequency Measurements

3-24. An external frequency counter may be used with the Tracking Generator/Spectrum Analyzer System for frequency measurements at any point on the CRT display. With the counter connected to the Tracking Generator AUX RF OUTPUT jack (rear panel) and the system operated in the MANUAL SCAN mode; the scan can be stopped at any point for frequency measurement.

CAUTION

Do not leave System stopped in MANUAL SCAN with high INTENSITY. Damage to the display CRT can result.

Figure 3-10 illustrates frequency measurement at the 30 dB point on a low-pass filter.

a. Spectrum Analyzer (8554B) control settings:

FREQUENCY 50 MHz
 BANDWIDTH300 kHz
 SCAN WIDTH PER DIVISION 10 MHz
 INPUT ATTENUATION 10dB
 SCAN TIME PER DIVISION 10 MILLISECONDS
 LOG REF LEVEL 0 dBm
 LOG/LINEAR LOG
 VIDEO FILTER OFF
 SCAN MODEINT
 SCAN TRIGGERAUTO

b. Tracking Generator control settings:

TRACK ADJ Peak
 LEVEL 0 dBm
 MANUAL SCAN CCW

c. Connect unit under test between Tracking Generator RF OUTPUT and Spectrum Analyzer RF INPUT.

d. Connect Tracking Generator AUX RF OUTPUT to Frequency Counter input.

e. Connect Tracking Generator SCAN OUTPUT to Spectrum Analyzer SCAN IN/OUT.

f. Connect Tracking Generator FIRST LO INPUT to Spectrum Analyzer FIRST LO OUTPUT and THIRD LO INPUT to THIRD LO OUTPUT.

g. Note point of interest on CRT display.

h. Set Spectrum Analyzer SCAN MODE to EXT and rotate Tracking Generator MANUAL SCAN control clockwise to point of interest.

i. Note and record frequency.

j. Set Spectrum Analyzer SCAN MODE to INT.

Note

The CRT trace (dot) can be moved in either direction by the Tracking Generator MANUAL SCAN control. For best frequency accuracy, approach frequency measurement point while tuning the MANUAL SCAN control in the clockwise direction.

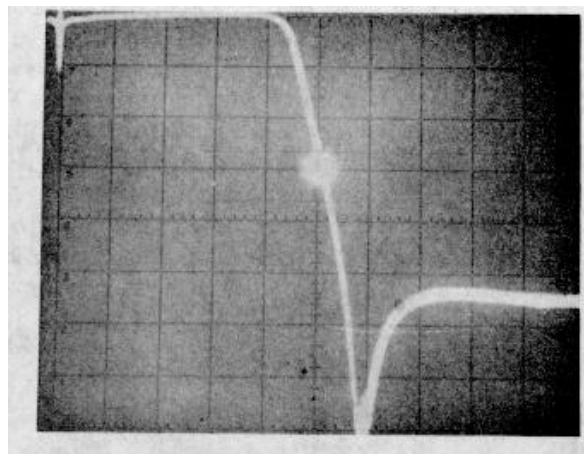

Figure 3-10. Precision Frequency Measurement CRT Display

**SECTION IV
PERFORMANCE TESTS**

4-1. INTRODUCTION

4-2. This section contains preset adjustment procedures and performance tests for the Model 8444A Tracking Generator and Model 8554L or 8555A/ 8552B/141T Spectrum Analyzer System. Preset adjustments for the 8444A/8554B/8552B/141T system are given in paragraph 4-7. Preset adjustments for the 8444A/8555A/8552B/141T are given in paragraph 4-9. Perform the preset adjustment procedures for the appropriate system prior to accomplishing the performance tests. Procedures for verifying that the instruments meet specifications are given in paragraphs 4-16 through 4-20.

4-3. EQUIPMENT REQUIRED

4-4. Test equipment and accessories for performance (P), adjustment (A) and troubleshooting (T) are listed in Table 1-3. Critical specifications and/ or required features for the test equipment and accessories are contained in the table. Each performance test lists the required test equipment and contains an illustrated test equipment setup.

4-5. FRONT PANEL CHECKS

4-6. Before proceeding to the performance tests, the instruments must be adjusted and all controls set as specified in the preset adjustment procedures for the appropriate system (8554B/8555A). The instruments should perform as called out in the preset adjustment procedures before going on to the performance tests.

4-7. Preset Adjustments (8554B/8552B/141T/ 8444A System)

4-8. Procedure:

- a. Apply power to Tracking Generator and Spectrum Analyzer.
- b. Turn Spectrum Analyzer INTENSITY control fully CCW.
- c. Allow instruments to warm up for at least 30 minutes.
- d. Perform Spectrum Analyzer 30 MHz calibration procedure. Refer to 8554B RF Section Operating Manual.

e. Connect Spectrum Analyzer FIRST LO OUTPUT to Tracking Generator FIRST LO INPUT.

f. Connect Spectrum Analyzer THIRD LO OUTPUT to Tracking Generator THIRD LO INPUT.

g. Connect Tracking Generator RF OUTPUT to Spectrum Analyzer RF INPUT.

h. Connect Tracking Generator SCAN OUTPUT to Spectrum Analyzer SCAN IN/OUT.

i. Set Spectrum Analyzer controls as follows:

INTENSITY 12 o'clock (approx.)
 FREQUENCY 30 MHz
 BANDWIDTH300 kHz
 SCAN WIDTHPER DIVISION
 SCAN WIDTH PER DIVISION200 kHz
 INPUT ATTENUATION 20 dB
 TUNING STABILIZEROn
 BASE LINE CLIPPERCCW
 SCAN TIME PER DIVISION 10 MILLISECONDS
 LOG/LINEAR10 dB LOG
 LOG REF LEVEL OdBm
 LOG REF LEVEL Vernier 0
 VIDEO FILTER OFF
 SCAN MODEINT
 SCAN TRIGGERLINE or AUTO

j. Set Tracking Generator controls as follows:

MANUALSCANCCW
 LEVEL OdBm

k. Adjust TRACK ADJ control for maximum amplitude of trace on CRT display.

l. If trace is *not* within +0.5 dB of LOG REF level graticule line repeat Spectrum Analyzer calibration procedure.

m. Reconnect Tracking Generator RF OUTPUT to Spectrum Analyzer RF INPUT and adjust TRACK ADJ for maximum signal amplitude.

n. Rotate LEVEL control fully counterclockwise (-10 dBm) and note signal level on CRT display.
 -10 to --12 dBm

o. If the signal level is off more than ±0.5 dB at the 0 dBm point or not within -10 to -12 dBm with the I, L, VEL control fully counterclockwise, refer to paragraph 4-16, Output Level Performance Check, a:1 -13 for LEVEL control calibration procedure.

MANUAL SCAN CCW
LEVEL dBm

k. Adjust TRACK ADJ control for maximum aptitude of trace on CRT display.

l. If trace is *not* within +0.5 dB of LOG REF level graticule line repeat Spectrum Analyzer calibration procedure.

m. Reconnect Tracking Generator RF OUTPUT to Spectrum Analyzer INPUT and adjust TRACK ADJ for maximum signal amplitude.

n. Rotate LEVEL control fully counterclockwise (-10 dBm) and note signal level on CRT display.

-10 to -12 dBm

o. If the signal level is off more than +0.5 dB at the 0 dBm point or not within -10 to -12 dBm with the LEVEL control fully counterclockwise, refer to paragraph 4-16, Output Level Performance Check, and 5-13 for LEVEL control calibration procedure.

4-9. Preset Adjustments (8555A/8552B/141T/ 8444A System)

4-10. Procedure:

- a. Apply power to Tracking Generator and Spectrum Analyzer.
- b. Turn Spectrum Analyzer INTENSITY , control fully CCW.
- c. Allow instruments to warm up for at least 30 minutes.
- d. Perform Spectrum Analyzer Operational Adjustments (30 MHz Calibration). Refer to 055t5 A RF Section Operating and Service Manual.
- e. Connect Spectrum Analyzer FIRST LO OUTPUT'11, -. Tracking Generator FIRST LO INPUT.
- f. Connect Spectrum Analyzer THIRD LO OUTPUT to Tracking Generator THIRD LO INPUT (rear panel connections).
- g. Connect Tracking Generator RF OUTPUT to Spectrum Analyzer INPUT.
- h. Connect Tracking Generator SCAN OUTPUT to Spectrum Analyzer SCAN IN/OUT.
- i. Set Spectrum Analyzer controls as follows:

INTENSIT' 12 o'clock (approx.)
 BAND..... n=1-(2.05 GHz IF)
 FREQUENCY 30 MHz
 BANDWIDTH300 kHz
 SCAN WIDTHPER DIVISION
 SCAN WIDTH PER DIVISION 100 kHz
 INPUT ATTENUATION 20dB
 TUNING STABILIZER ON
 SIGNAL IDENTIFIER OFF
 BASE LINE CLIPPERCCW
 SCAN TIME PER DIVISION 10 MILLISECONDS
 LOG /LINEAR 10 dB LOG
 LOG REF LEVEL 0 dBm
 LOG REF LEVEL Vernier 0
 VIDEO FILTER OFF
 SCAN MODEINT
 SCAN TRIGGERLINE or AUTO

j. Set Tracking Generator controls as follows:

4-11. PERFORMANCE TESTS

4-12. The performance tests, given in this section, are suitable for incoming inspection, troubleshooting, and/or preventive maintenance. During any performance test, all shields and connecting hardware must be in place. The tests are designed to verify published specifications. Perform the tests in the order given, and record data on test card (Table 4-1) and/or in the data spaces provided in each test.

4-13. The tests are arranged in the following order:

<u>Paragraph</u>	<u>Test Description</u>
4-16	Output Level and flatness
4-17	Frequency Stability
4-18	System Flatness
4-19.	Frequency Accuracy
4-20	Distortion

4-14. Each test is arranged so that the specification is written as it appears in the Table of Specifications (Table 1-1) in Section I. Next, a description of the test and any special instructions or problem areas are included. Each test that requires test equipment has a test setup drawing and a list of required equipment. Each procedure gives control settings required for that particular test.

4-15. Required minimum specifications for test specifications listed in order to performance-test equipment are detailed in Table 1-3 in Section I. If the

Tracking Generator, substitute test equipment is used, it must meet the

PERFORMANCE TESTS

4-16. Output Level

SPECIFICATION: Tracking Generator (Drive Level to Test Device): 0 to -10 dBm continuously variable. 0 dBm calibrated to +0.5 dB. Flatness: +0.5 dB.

DESCRIPTION: With the Tracking Generator connected to the Spectrum Analyzer, the Tracking Generator output level is first checked at 30 MHz (Spectrum Analyzer amplitude calibration point) with a power meter. With Tracking Generator LEVEL control set at 0 dBm, the power meter indication should be 0 dBm +0.5 dB. With LEVEL control set fully counterclockwise, the power meter indication should be -10 dBm to -12 dBm. The flatness of the Tracking Generator output is checked using a power meter from 10 MHz to 1.3 GHz if used with the 8555A, and 500 kHz to 1.25 GHz if used with the 8554B. The overall maximum power variation in each case must not exceed 1 dB (+0.5 dB).

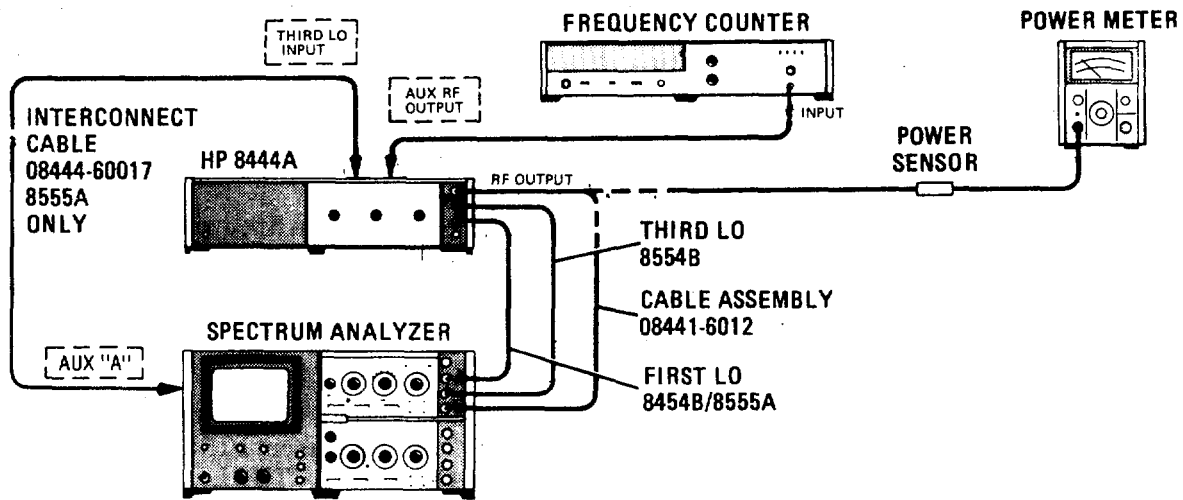

Figure 4-1. Output Level and Flatness Test Setup

EQUIPMENT:

Spectrum Analyzer	HP 8554B or 8555A/8552B/141T
Power Meter	HP 435A
Power Sensor	HP 8482A
Frequency Counter	HP 5340A
Adapter, Type N Male to BNC Female	HP 1250-0780
Interconnect Cable (8555A THIRD LO)	HP 08444-60017
Interconnect Cable (two required)	HP 08444-60018
Cable Assembly (RF)	HP 08441-6012

PERFORMANCE TESTS

4-16. OUTPUT LEVEL AND FLATNESS (Cont'd)

PROCEDURE:

1. Perform preset adjustment procedures, paragraph 4-7 for 8554B/8552B/141T Spectrum Analyzer System or paragraph 4-9 for 8555A/8552B/141T Spectrum Analyzer System.
2. Connect test setup as shown in Figure 4-1 and set controls as follows:

Power Meter

RANGE 0 dBm
 LINE ON
 CAL FACTOR See Power Sensor

Frequency Counter

RANGE 10 Hz-18 GHz
 LINE ON
 RESOLUTION Hz 100

Tracking Generator

MANUAL SCAN Fully Counterclockwise
 LEVEL 0 dBm

3. Set Spectrum Analyzer TUNING STABILIZER to OFF and set SCAN WIDTH to ZERO. Adjust FREQUENCY for indication of 30 MHz \pm 100 kHz on Frequency Counter.
4. Tune Tracking Generator TRACK ADJ for maximum signal amplitude on Spectrum Analyzer.
5. Connect Power Sensor to 435A POWER REF OUTPUT and ZERO Power Meter. Set rear-panel POWER REF switch to ON (up). Set CAL ADJ for proper 435A indication. Remove Power Sensor and return POWER REF switch to OFF.
6. Disconnect cable at Tracking Generator RF OUTPUT and connect Power Sensor to RF OUTPUT connector. Disconnect FIRST LO cable and ZERO Power Meter. Reconnect FIRST LO cable. Measure and record power level.

MAX.	ACTUAL	MIN.
+0.5 dBm	___dBm	___-0.5 dBm

7. Set Tracking Generator LEVEL control fully counterclockwise. Measure and record power level.

MAX.	ACTUAL	MIN.
-10dBm	___dBm	___-12 dBm

8. Adjust Tracking Generator LEVEL control to set a -1 dBm reference level on power meter.
9. With Spectrum Analyzer FREQUENCY control, slowly tune the Spectrum Analyzer and Tracking Generator between 10 MHz and 1.3 GHz if using 8555A RF Section, or between 500 kHz and 1.25 GHz if using 85S4B RF Section.

10. Note and record the maximum overall power deviation.

MAX.	ACTUAL
1 dB	___dB
(\pm 0.5 dB)	

PERFORMANCE TESTS

This space intentionally left blank.

4-17. Frequency Stability

SPECIFICATION: Stability: Residual FM (peak-to-peak):

<u>Tuning Section</u>	<u>Stabilized</u>	<u>Unstabilized</u>
8554B/8555A 200 Hz	10 kHz	

DESCRIPTION: The stability of the Spectrum Analyzer/Tracking Generator System is checked using a HP 141T/8553B/8552B Spectrum Analyzer System which has less than 20 Hz peak-to-peak residual FM. The Spectrum Analyzer in the system must be within residual FM specification limits. Refer to appropriate RF Section Operating and Service Manual. There are no adjustments in the Tracking Generator for residual FM. Refer to paragraph 5-10 if residual FM is excessive.

PERFORMANCE TESTS

4-17. Frequency Stability (cont'd)

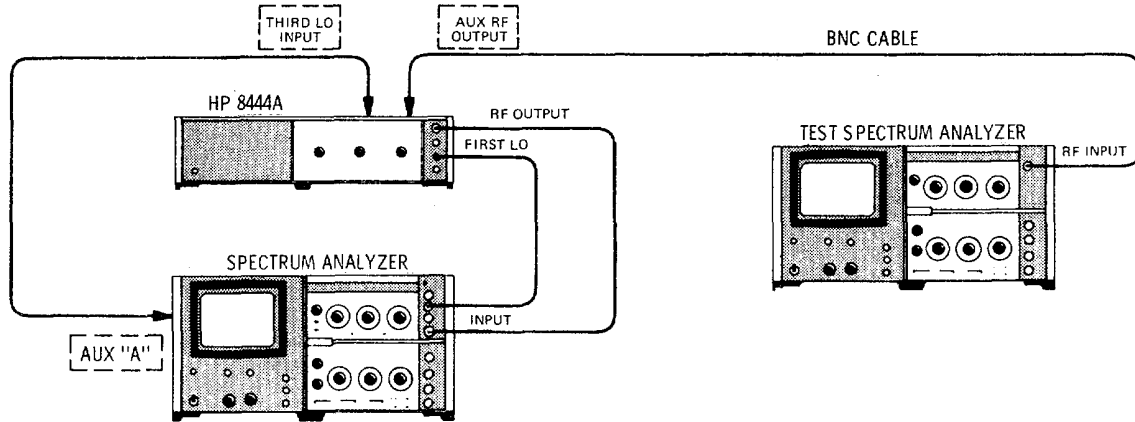

Figure 4-2. Residual FM Test Setup

EQUIPMENT:

Spectrum Analyzer	HP 8554B or 8555A/8552B/141T
Test Spectrum Analyzer	HP 8553B/8552B/141T
BNC Cable	HP 10503A

PROCEDURE:

1. Perform preset adjustment procedures, paragraph 4-7, for 8554B/8552B/141T Spectrum Analyzer System or paragraph 4-9 for 8555A/8552B/141T Spectrum Analyzer System.

2. Connect test setup as indicated in Figure 4-2 and make the following control settings:

SPECTRUM ANALYZER (Tracking Generator/Spectrum Analyzer System) See paragraph 4-7 or 4-9.

SPECTRUM ANALYZER (8553B/8552B/141T "Test Analyzer")

POWER	ON
RANGE MHz	0-110
FREQUENCY	50 MHz
BANDWIDTH	30 kHz
SCAN WIDTH	PER DIVISION
SCAN WIDTH PER DIVISION	1 MHz
INPUT ATTENUATION	10 dB,
TUNING STABILIZER	ON
CAN TIME PER DIVISION	20 MILLISECONDS
LOG/LINEAR	10 dB LOG
LOG REF LEVEL	+10 dBm
VIDEO FILTER	10 kHz
CAN MODE	INT
CAN TRIGGER	AUTO

3. Set Tracking Generator/Spectrum Analyzer System FREQUENCY to 50 MHz and SCAN WIDTH to ZERO.

PERFORMANCE TESTS

4-17. Frequency Stability (cont'd)

4. Connect Tracking Generator AUX RF OUTPUT to Test Analyzer RF INPUT.
5. Adjust Test Analyzer FREQUENCY control to center signal on CRT Display.
6. Reduce Test Analyzer BANDWIDTH to 1 kHz and SCAN WIDTH PER DIVISION to 2 kHz while keeping signal centered on CRT display.
7. Set Test Analyzer INPUT ATTENUATION to 30 dB, LOG/LINEAR to LINEAR, and LINEAR SENSITIVITY to 20.mV/DIV.
8. Adjust Test Analyzer LINEAR SENSITIVITY Vernier control for a full eight division display.
9. Refer to Figure 4-3. Tune Test Analyzer FINE TUNE so that the upward slope of the display intersects the CENTER FREQUENCY graticule line one division from the top.

NOTE

The linear portion of the analyzer IF filter skirt is used to slope detect low-order residual FM. The analyzer is stabilized, and the detected FM is displayed in the time domain.

10. Note where the slope intersects the middle horizontal graticule line: Horizontal Displacement: _____ divisions
11. Use the horizontal displacement to calculate demodulation sensitivity.
 - a. Convert the horizontal displacement (divisions) into Hertz.

Example: (2 kHz SCAN WIDTH) x (0.2 div) = 400 Hz.

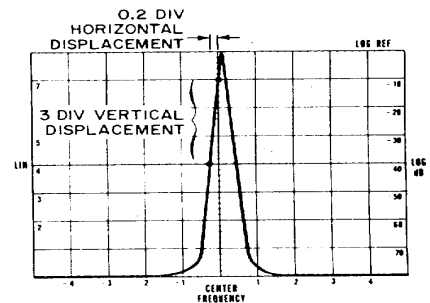

Figure 4-3. Demodulation Sensitivity Measurement

- b. Calculate demodulation sensitivity by dividing the vertical displacement in divisions into the horizontal displacement in Hz:

$$\frac{400 \text{ Hz}}{3 \text{ divisions}} = 133 \text{ Hz/div}$$
12. Turn SCAN WIDTH to ZERO scan. Set FINE TUNE for a response level within the calibrated three division range (one division from the top to the center horizontal graticule line).
13. Measure the peak-to-peak deviation, and multiply it by the demodulation sensitivity obtained in step lib above.
14. Example: 1.2 div p-p signal deviation x 133 Hz/div = 159.6 Hz Residual FM.

_____ Hz peak-to-peak

PERFORMANCE TESTS

4-18. SYSTEM FLATNESS

SPECIFICATION:

Amplitude Accuracy: System Frequency Response: 1.50 dB.

DESCRIPTION:

The Tracking Generator output is checked with the Spectrum Analyzer using either an 8555A or an 8554B RF Section. A convenient reference level is set in the 2 dB LOG mode. The overall power deviation is measured from 10 MHz to 1.3 GHz if 8555A RF Section is used, or 500 kHz to 1.25 GHz if 8554B RF Section is used.

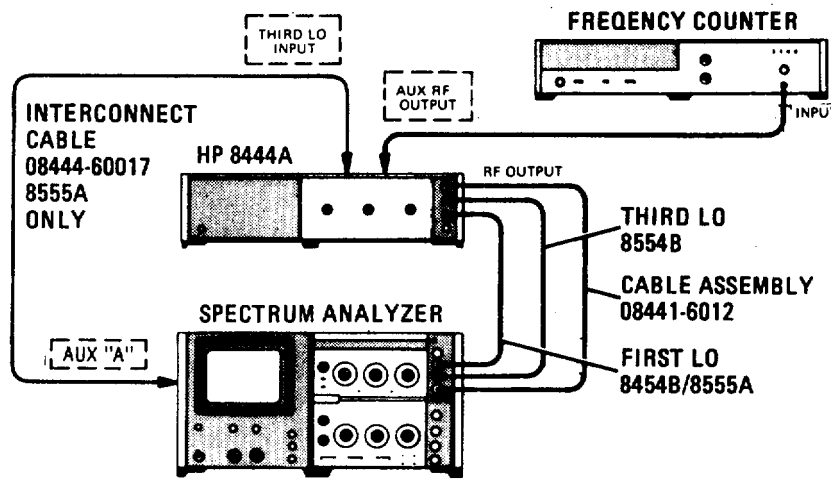

Figure 4-4. System Flatness Test Setup

EQUIPMENT:

Spectrum Analyzer	HP 8554B or 8555A/8552B/141T
Frequency Counter	HP 5340A
Adapter, Type N Male to BNC Female	HP 1250-0780
Interconnect Cable (8555A THIRD LO)	HP 08444-60017
Interconnect Cable (two required)	HP 08444-60018
Cable Assembly	HP 08441-6012

PERFORMANCE TESTS

4-18. SYSTEM FLATNESS (Cont'd)

PROCEDURE:

1. Perform preset adjustment procedures, paragraph 4-7 for 8554B/8552B/141T Spectrum Analyzer System or paragraph 4-9 for 8555A/8552B/141T Spectrum Analyzer System.
2. Connect test setup as shown in Figure 44 and set controls as follows:

Frequency Counter

RANGE 10 Hz-18 GHz
 LINE..... ON
 RESOLUTION Hz 100

Tracking Generator

MANUAL SCAN Fully Counterclockwise
 LEVEL 0 dBm

3. Set Spectrum Analyzer SCAN WIDTH to ZERO and adjust FREQUENCY for indication of 30 MHz + 100 kHz on frequency counter.
4. Set Spectrum Analyzer LOG REF LEVEL to (+) 10 dBm and LOG/LINEAR to 2 dB LOG.
5. Adjust Tracking Generator TRACK ADJ for maximum signal indication on CRT display.
6. Adjust Spectrum Analyzer LOG REF LEVEL vernier control to position trace on -20 LOG REF graticule line.
7. With Spectrum Analyzer FREQUENCY control, slowly tune the Spectrum Analyzer and Tracking Generator between 10 MHz and 1.3 GHz if using 8555A RF Section, or between 500 kHz and 1.25 GHz if using 8554B RF Section.
8. Note and record the maximum overall power deviation (one minor division on center vertical graticule line equals 0.4 dB).

MAX. ACTUAL
 3 dB
 (±1.5 dB) ____dB

PERFORMANCE TESTS

4-19. Frequency Accuracy

SPECIFICATION: Frequency Accuracy: +15 MHz using Spectrum Analyzer slide rule dial. Precision frequency measurements: Frequency Accuracy: +10 kHz for unknown signals (using Tracking Generator AUX RF OUTPUT and an external frequency counter).

DESCRIPTION: The accuracy of the slide rule dial is determined by the RF Section calibration. Refer to dial accuracy performance test in the appropriated RF Section Operating and Service manual. For precision frequency measurements, frequency accuracy is checked by tuning the Spectrum Analyzer and Tracking Generator to a known frequency and measuring the Tracking Generator output with an external counter. The slide rule dial can be visually checked for an accuracy of +15 MHz.

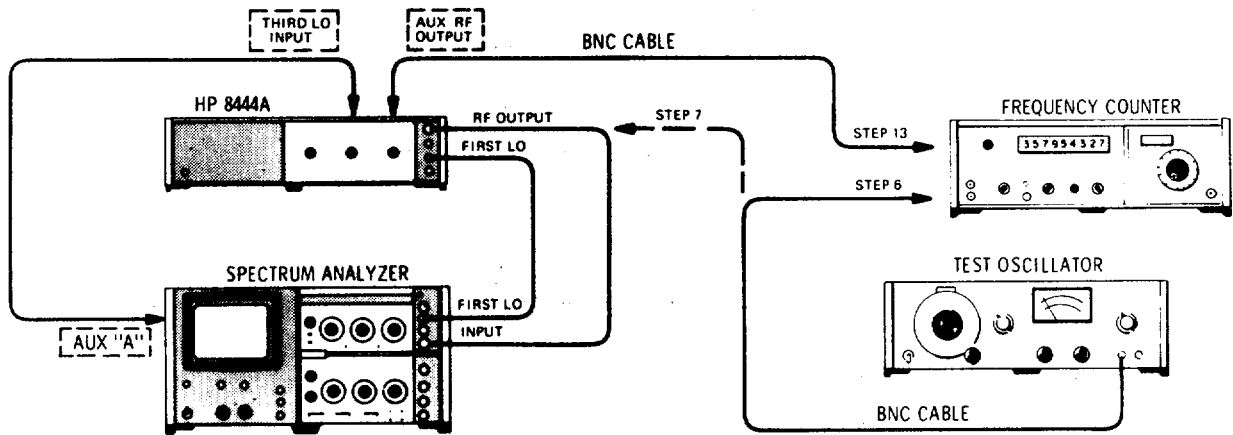

Figure 4-5. Frequency Accuracy Test Setup

EQUIPMENT:

Spectrum Analyzer.....	HP 8554B/8555A/8552A/141T
Frequency Counter.....	HP 5340A
Test Oscillator.....	HP 652A
HF Signal Generator.....	HP 606A/B
VHF Signal Generator.....	HP 608E/F
UHF Signal Generator.....	HP 612A
Cable Assembly	HP 10503A

PROCEDURE:

1. Perform preset adjustment procedures, paragraph 4-7, for 8554B/8552B/141T Spectrum Analyzer System or paragraph 4-9 for 8555A/8552B/141T Spectrum Analyzer System.
2. Connect test setup as indicated in Figure 4-5 and make the following control settings: Spectrum Analyzer See paragraph 4-7 or 4-9.

Frequency Counter

SAMPLE RATE	12 o'clock
SENSITIVITY	1 (VOLTS RMS)
TIME BASE	10 ms
FUNCTION	FREQUENCY

PERFORMANCE TESTS

4-19. Frequency Accuracy (cont'd)

Tracking Generator

TRACK ADJ Max signal amplitude
 LEVEL 0 dBm
 MANUAL SCAN CCW

Test Oscillator

(8555A) FREQUENCY 500 kHz (8554B); 10 MHz
 OUTPUT ATTENUATOR OdBm

3. Allow instruments to warm up and stabilize for at least 2 hours.
4. Set Spectrum Analyze SCAN WIDTH PER DIVISION to 5 MHz, BANDWIDTH to 30 kHz, center FINE TUNE control and set FREQUENCY to 0 MHz.
 Note
 During all adjustments of FREQUENCY control approach dial setting in a clockwise direction.
5. Check displacement of LO feed thru signal from CRT CENTER FREQUENCY graticule line.
 $\leq 3 \text{ Div}$ _____
6. Connect Test Oscillator 50o output to Frequency Counter and adjust oscillator frequency for an indication of 500 kHz (8554B) or 10 MHz (8555A).
7. Disconnect cable between Tracking Generator RF OUTPUT and Spectrum Analyzer INPUT.
8. Connect Test Oscillator to Spectrum Analyzer INPUT and tune Spectrum Analyzer to Test Oscillator frequency.
9. Reduce Spectrum Analyzer SCAN WIDTH PER DIVISION to 5 kHz and BANDWIDTH to 1 kHz keeping signal centered on CRT display with FREQUENCY and FINE TUNE controls.
10. Set SCAN WIDTH to ZERO and tune FINE TUNE for maximum signal amplitude.
11. Disconnect Test Oscillator from Spectrum Analyzer and connect Tracking Generator OUTPUT to Spectrum Analyzer INPUT.
12. Adjust Tracking Generator TRACK ADJ for maximum signal amplitude on CRT display.
13. Connect Tracking Generator AUX RF OUTPUT to Frequency Counter. Measure and record frequency.
 8554B 500 +10 kHz _____
 8555A 10MHz+10kHz _____
14. Repeat steps 6 through 13 at selected frequencies using appropriate signal generator in place of test oscillator.

PERFORMANCE TESTS

4-20. Harmonic Distortion

SPECIFICATION: Harmonic Distortion: 25 dB below output level. Nonharmonic (spurious) signals: >40 dB below output level.

DESCRIPTION: With the Tracking Generator and Spectrum Analyzer operating as a system, the RF OUTPUT from the Tracking Generator is observed using a separate spectrum analyzer. The output signal is checked for signal level of both harmonic and spurious signals.

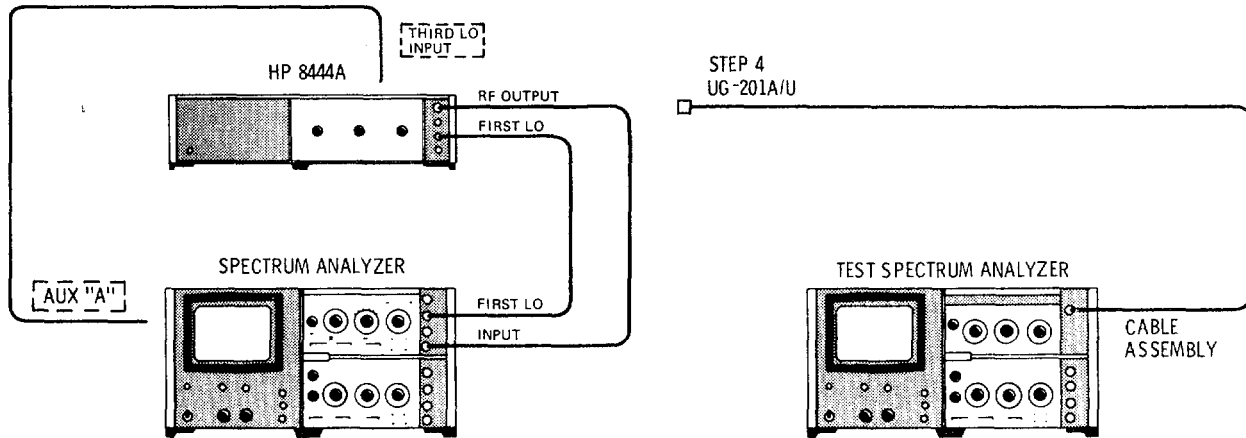

Figure 4-6. Harmonic Distortion Test Setup

EQUIPMENT:

Spectrum Analyzer	HP 8554B or 8555A/8552B/141T
Test Spectrum Analyzer	HP 8553B/8552B/141T
RF Section	HP 8554B or 8555A
BNC Cable	HP 10503A
Adapter	UG-201A/U

PROCEDURE:

1. Perform preset adjustment procedures, paragraph 4-7, for 8554B/8552/141T Spectrum Analyzer System or paragraph 4-9 for 8555A/8552/141T Spectrum Analyzer System.
2. Connect test setup as indicated in Figure 4-6 and make the following control settings:

Tracking Generator/Spectrum Analyzer System

See paragraph 4-7 or 4-9.

Spectrum Analyzer (8553B/8552B/141T "Test Analyzer")

FREQUENCY	50 MHz
BANDWIDTH	300 kHz
SCAN WIDTH	PER DIVISION
SCAN WIDTH PER DIVISION	0 MHz
INPUT ATTENUATION	20 dB
BASE LINE CLIPPER	10 o'clock
VIDEO FILTER	OFF
SCAN TIME PER DIVISION	2 MILLISECONDS
LOG/LINEAR	10 dB LOG

PERFORMANCE TESTS

4-20. Harmonic Distortion (cont'd)

LOG REF LEVEL 0 dBm
 LOG REF LEVEL Vernier..... 0
 SCAN MODE INT
 SCAN TRIGGER LINE

Tracking Generator/Spectrum Analyzer System

Tracking Generator

TRACK ADJ Max signal level
 LEVEL 0 dBm

Spectrum Analyzer

BAND* n=1 - (2.05 GHz IF)
 FREQUENCY 50 MHz
 TUNING STABILIZER OFF
 SIGNAL IDENTIFIER* OFF
 BANDWIDTH..... 300 kHz
 SCAN WIDTH..... PER DIVISION
 SCAN WIDTH PER DIVISION 10 MHz
 INPUT ATTENUATION 20 dB
 BASE LINE CLIPPER 9 o'clock
 SCAN TIME PER DIVISION 0.5 SECONDS
 LOG/LINEAR 10 dB LOG
 LOG REF LEVEL Vernier 0
 VIDEO FILTER OFF
 SCAN MODE INT
 SCAN TRIGGER LINE

*8555A RF Section only

3. Disconnect the cable between Tracking Generator RF OUTPUT and Spectrum Analyzer INPUT.
4. Connect cable between Tracking Generator RF OUTPUT and the INPUT of the "Test Analyzer".
5. Observe the "Test Analyzer" display for harmonic and spurious signals. A typical display is shown in Figure 4-7. The Tracking Generator fundamental signal is shown between the -2 and -1 graticule lines. The second harmonic is shown between the +1 and +2 lines with the third harmonic shown between the +4 and +5 lines. The amplitude of the second harmonic is approximately 36 dB below the fundamental. The third harmonic is down approximately 50 dB. A spurious signal with an amplitude of approximately -58 dBm is shown between the -4 and -3 graticule lines.
6. Change the Tracking Generator/Spectrum Analyzer System controls as follows:

Tracking Generator

LEVEL -10 dBm (CCW)

Spectrum Analyzer

FREQUENCY 250 MHz
 SCAN WIDTH PER DIVISION 50 MHz
 SCAN TIME PER DIVISION..... 1 SECOND

7. Replace the "Test Analyzer"* RF Section with either an 8554B or 8555A RF Section.

PERFORMANCE TESTS

4-20. Harmonic Distortion (cont'd)

8. Set "Test Analyzer" controls as follows:

FREQUENCY	250 MHz
BANDWIDTH	300 kHz
SCAN WIDTH	PER DIVISION
SCAN WIDTH PER DIVISION	50 MHz
INPUT ATTENUATION	20 dB
BASE LINE CLIPPER	12 o'clock
VIDEO FILTER	OFF
SCAN TIME PER DIVISION.....	10 MILLISECONDS
LOG/LINEAR	10 dB LOG
LOG REF LEVEL	10 dBm
LOG REF LEVEL Vernier	0
SCAN MODE	INT
SCAN TRIGGER	LINE

- 9. Observe the "Test Analyzer" display for harmonic and spurious signals.
- 10. Figure 4-8 illustrates a typical display of the LO feedthru, fundamental and second harmonic signals.
- 11. Repeat the above procedure at frequency of interest.
- 12. Note and record maximum amplitude level of harmonic and spurious signals.

Harmonics \leq -25 dBm _____
Spurious \leq - 40 dBm _____

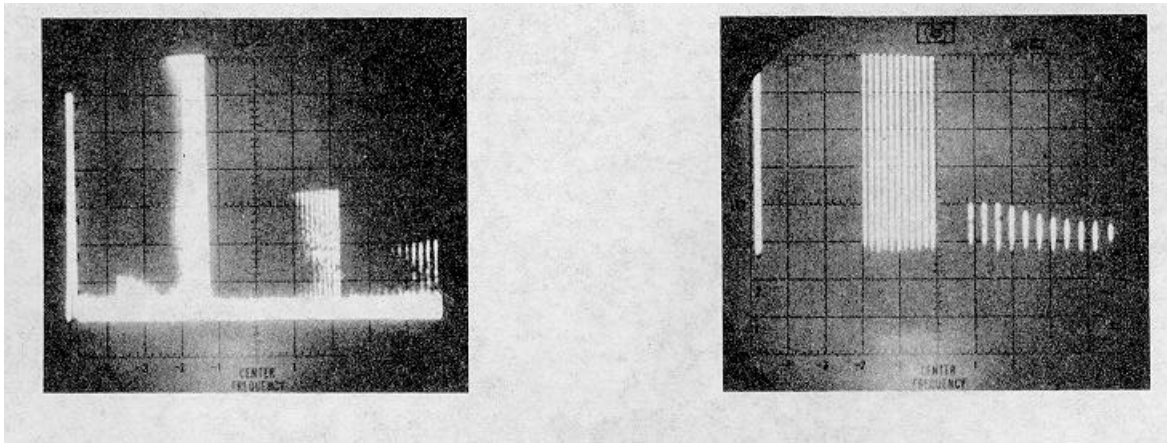

Figure 4-7. Typical Harmonic Distortion
CRT Display 0 to 100 MHz

Figure 4-8. Typical Harmonic Distortion
CRT Display 0 to 500 MHz

Table 4-1. Performance Test Record

Hewlett-Packard Model 8444A Tracking Generator		Tested by _____			
Serial No. _____		Date _____			
Para. No.	Test Description	Measurement Unit	Min	Actual	Max
4-16	Output Level (Step 6)	dBm	-0.5	_____	+0.5
	(Step 7)	dBm	-10	_____	-12
	(Step 37)	dB	-1	_____	+1
4-17	Residual FM (peak-to-peak)				
	8554B Stabilized	Hz		_____	200
	8555A Stabilized	Hz		_____	200
	8554B Unstabilized	kHz		_____	10
	8555A Unstabilized	kHz		_____	10
4-18	System Flatness				
	500 kHz to 1250 MHz (8554B)	dB	-1.5	_____	+1.5
	10 to 1300 MHz (8555A)	dB	-1.5	_____	+1.5
4-19	Frequency Accuracy				
	Dial Accuracy (Step 5)	MHz	-15	_____	+15
	Frequency Accuracy (Step 13)	kHz	-10	_____	+10
4-20	Harmonic Distortion				
	Harmonic Signal Level	dBm		_____	-25
	Spurious Signal Level	dBm		_____	-35

SECTION V ADJUSTMENTS

5-1. INTRODUCTION

5-2. This section describes adjustments required to return the Tracking Generator to peak operating condition after repairs are made. Included in this section are test setups, and check and adjustment procedures. A test card for recording data is included at the back of this section. Adjustment and test point location illustrations are contained in Figures 8-4 and 8-5.

5-3. The adjustment procedures are arranged in numerical order. For best results, this order should be followed. Record data, taken during adjustments, in the spaces provided and/or in the data test card at the end of this section. Comparison of initial data with data taken during periodic adjustments assists in preventive maintenance and troubleshooting.

Note

Control settings are called out for a HP 8555A Spectrum Analyzer RF Section. If the RF Section used is a HP 8554B disregard BAND and SIGNAL

IDENTIFIER control settings. Otherwise, the Spectrum Analyzer control settings apply to either instrument.

5-4. EQUIPMENT REQUIRED

5-5. Each check and adjustment procedure contains a list of test equipment required for that particular test. Table 1-3 contains a tabular list of test equipment and accessories required. In addition, the table contains the required minimum specifications and a suggested manufacturers model number.

5-6. FACTORY SELECTED COMPONENTS

5-7. Factory selected components are designated by an asterisk (*) on the schematic diagrams in Section VIII of this manual. Table 8-1 contains a list of factory selected components by reference designation, basis of selection, and schematic diagram location on which the component is illustrated.

ADJUSTMENTS

5-8. Power Supply, Check and Adjustment

REFERENCE: Service Sheet 5.

DESCRIPTION: Power supplies in the Tracking Generator provide regulated output of +20 and -10 volts. The +20 volt supply is adjustable and provides the reference for the -10 volt supply. These checks verify proper operation of the power supplies.

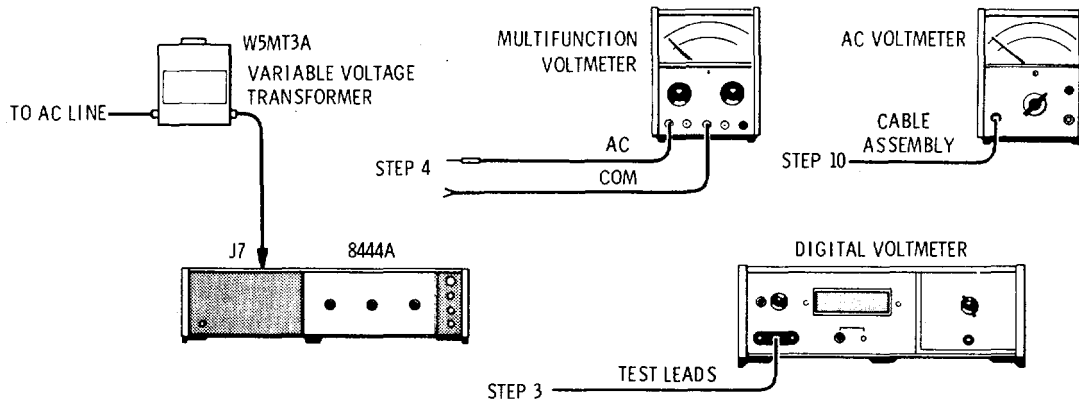

Figure 5-1. Power Supply Check and Adjustment Test Setup

EQUIPMENT:

Digital Voltmeter with 3443A Plug-in	HP 3440A
AC Voltmeter (Multifunction Voltmeter)	HP 410C
Variable Voltage Transformer	General Radio W5MT3A
AC Voltmeter	HP 400E
Cable Assy (terminated with probe and alligator clip)	HP 10501A
Cable Assy (dual banana plug to probe and alligator clip)	HP 11003A

PROCEDURE:

1. Connect test setup as indicated in Figure 5-1.
2. Remove top cover and right side cover from Tracking Generator.
3. Connect digital voltmeter test leads to AITP1 and chassis ground.
4. Remove shield from power line module and connect ac voltmeter (HP 410C) across the outside terminals of the ACCESSORY OUTLET connector J6. (The outside terminals of J6 are connected by the 98 and 908 color coded wires to the power line module.)

ADJUSTMENTS

5. Apply power to the Tracking Generator. Measure and record the +20 volt output. Vary the input ac line voltage from 103.5 to 126.5 volts. The +20 volt regulated output should not vary more than 20 mV.

AC Input	+20 Vdc Output
103.5V	_____
115V	_____
126.5V	_____

6. Set ac line voltage to 115 volts. Adjust AIR14 for +20.00 Vdc +20 mV at test point A1TP1.
7. Disconnect ac voltmeter from connector J6.
8. Connect digital voltmeter to A7C3 and chassis ground (-10 volt test point).
9. Measure and record voltage level. Voltage level should be -10.0 +0.5 volts.
-10.0 Vdc Output _____
10. Set HP 400E AC Voltmeter RANGE to .001 VOLTS full scale and measure ac ripple on +20 and -10 volt sense lines. Ripple should be less than 200 pV. Measure and record ac ripple between power supply sense lines and chassis ground.
+20 Volt Output XA1 pin 6 _____
 -10 Volt Output A7C3 _____
11. Remove input line power and replace cover over power line module.
12. Replace right side cover and top cover.
13. If the dc supplies are out of tolerance, refer to Service Sheet 5 for trouble isolation procedure.

ADJUSTMENTS

5-9. 1.55 GHz Oscillator Power Level, Frequency Check and Adjustment

REFERENCE: Service Sheet 3.

DESCRIPTION: The 1.55 GHz local oscillator is checked for power output level and frequency tuning range. Oscillator frequency is determined primarily by the LO cavity, with tuning range determined by the drive voltage from the oscillator driver. The oscillator is checked first for power level and then for frequency and tuning range.

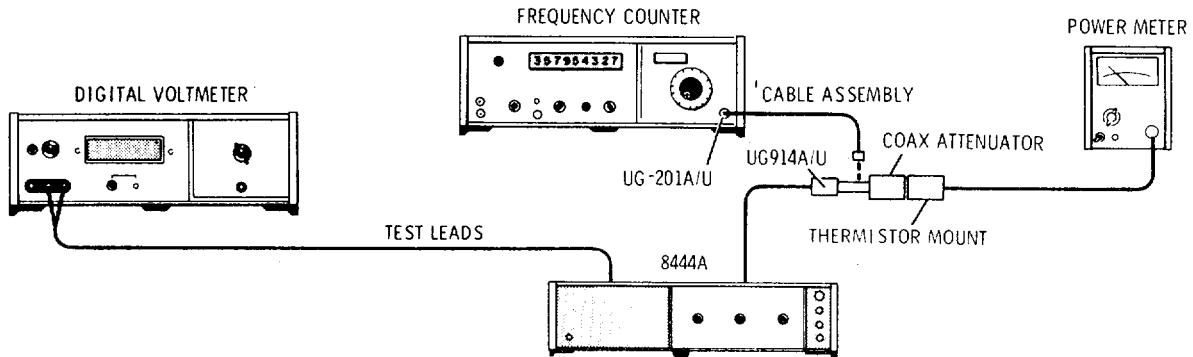

Figure 5-2. 1.55 GHz LO Power Level and Frequency Check and Adjustment Test Setup

EQUIPMENT:

Power Meter with HP 8478B Thermistor Mount	HP 432A
Frequency Counter with HP 5254C Plug-in	HP 5245L
Digital Voltmeter with HP 3443A Plug-in	HP 3440A
Test Leads (dual banana plug to probe and alligator clip)	HP 11003A
Cable Assy, SMA male to BNC male	HP 08555-60076
Cable Assy, male BNC connectors	HP 10503A
Coaxial Attenuator, Option 010	HP 8491A
Adapter BNC barrel (HP Part Number 1250-0080)	UG 914A/U
Adapter (BNC to Type N)	UG 201A/U

PROCEDURE:

1. Perform Power Supply Check and Adjustment, paragraph 5-8.
2. Apply power to Tracking Generator and allow 1 hour for instrument to warm up and stabilize.
3. Disconnect Cable W8 at Isolator AT3 J2 (see Figures 8-4 and 8-12).
4. With test setup as indicated in Figure 5-2, connect Power Meter to Isolator AT3 J2 via 08555-60076 cable, .10 dB attenuator and UG 914A/U adapter.
5. Rotate TRACK ADJ control throughout its tuning range while noting power level indicated on Power Meter.
6. Minimum power output must be greater than +5 dBm.

>+5 dBm _____

ADJUSTMENTS

5-9. 1.55 GHz Oscillator Power Level, Frequency Check and Adjustment (cont'd)

7. Connect Frequency Counter to Isolator AT3 J2 via 08555-60076 cable, UG 914A/U adapter and BNC to BNC cable.
 8. Rotate TRACK ADJ control fully counterclockwise and record oscillator frequency.
 9. Rotate TRACK ADJ control fully clockwise and record oscillator frequency 1, 548, 000 \pm 500 kHz _____
 10. Record frequency tuning range (frequency recorded in step 9 minus frequency recorded in step 8). 1, 552, 000 +500 kHz _____
 11. If data recorded in steps 8, 9, and 10 is within tolerance no adjustment is required.
 12. If data recorded in steps 8, 9, or 10 is not within tolerance proceed with step 13.
 13. Connect Digital Voltmeter to test point A2TP5.
 14. Set TRACK ADJ control fully clockwise. Set "MAX" TUNE potentiometer A2R26 and "MIN" TUNE potentiometer A2R27 fully counterclockwise. Measure voltage at A2TP5. Voltage should be $+1 \pm 0.1$ Vdc. 4, 000 \pm 500 kHz _____
 15. Measure and record oscillator frequency. +0.9_____+1.1 Vdc
 16. Adjust "MAX" TUNE potentiometer A2R26 to increase oscillator frequency 4, 000 +50 kHz above frequency recorded in step 15. Record oscillator frequency.
 17. Set TRACK ADJ control to center of tuning range recorded in steps 15 and 16 above. Record oscillator frequency.
 18. If frequency recorded in step 17 is not within +500 kHz of 1.550 GHz adjust A7ADJ 1 to tune oscillator frequency to 1.550 GHz \pm 100 kHz.
 19. If oscillator frequency is adjusted, repeat steps 15 through 18.
 20. Disconnect Power Meter and connect W8 Cable to Isolator AT3 J2.
 21. Replace right side panel cover.
-

ADJUSTMENTS

5-10. 1.55 GHz Oscillator Residual FM Check

REFERENCE: Service Sheet 3.

DESCRIPTION: The 1.55 GHz oscillator is checked for residual FM by mixing the oscillator output with a stable signal source and observing the resultant output on a calibrated spectrum analyzer display. The second converter in Tracking Generator is used to mix the oscillator output with the 1500 MHz comb signal from a Frequency Comb Generator. The mixer output is displayed using a HP 141T/8553B/8552B Spectrum Analyzer System which has less than 20 Hz peak-to-peak residual FM. There are no adjustments for oscillator residual FM. Perform power supply check for excessive ripple if residual FM is excessive.

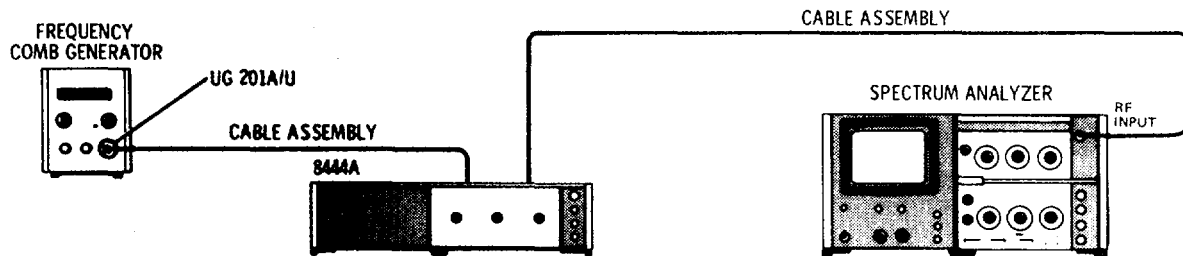

Figure 5-3. 1.55 GHz LO Residual FM Check Test Setup

EQUIPMENT:

Spectrum Analyzer System	HP 141T/8553B/8552B
Frequency Comb Generator	HP 8406A
Cable Assy, Selectro male to Selectro female	HP 11592-60003
Cable Assy, Selectro female to BNC male (2 each).....	HP 11592-60001
Adapter (BNC to Type N)	UG 201A/U

PROCEDURE:

1. Perform Power Supply Check and Adjustment, paragraph 5-8.
2. Perform 1.55 GHz Oscillator Power Level, Frequency Check and Adjustment, paragraph 5-9.
3. Apply power to Spectrum Analyzer System, Frequency Comb Generator and Tracking Generator. Allow at least one (1) hour for equipment stabilization.
4. Disconnect Cable W4 at Mixer Assy A6 and Cable W8 at First Converter A5J2 (see Figures 8-4 and 8-12). Connect 11592-60003 cable between W8 and A6 J1.
5. Disconnect Cable W9 from A6 J2 and connect 11592-60001 cable between A6 J2 and Frequency Comb Generator.
6. Disconnect Cable W10 from A6 J3 and connect 11592-60001 cable between A6 J3 and Spectrum Analyzer RF input.
7. Set instrument controls as follows:

ADJUSTMENTS

5-10. 1.55 GHz Oscillator Residual FM Check (cont'd)

Tracking Generator

LINE OFF/ONON
TRACK ADJ..... Centered

Frequency Comb Generator

COMB FREQUENCY - MHz 100 MHz
OUTPUT AMPLITUDE Maximum (CW)

Spectrum Analyzer

POWER ON
RANGE MHz 0-110
FREQUENCY 50 MHz
BANDWIDTH 30 kHz
SCAN WIDTH PER DIVISION
SCAN WIDTH PER DIVISION 1 MHz
INPUT ATTENUATION 0 dB
TUNING STABILIZER..... ON
SCAN TIME PER DIVISION 20 MILLISECONDS
LOG/LINEAR 10 dB LOG
LOG REF LEVEL +10 dBm
VIDEO FILTER 10 kHz
SCAN MODE INT
SCAN TRIGGER AUTO

8. Rotate Tracking Generator TRACK ADJ control while observing CRT display.

NOTE

With the 1.55 GHz oscillator tuned to 1550 MHz both the 1500 and 1600 MHz comb signals will produce a response at 50 MHz.

9. Adjust the TRACK ADJ control until the responses are separated by 2 MHz (2 divisions) on the display.
10. Adjust Spectrum Analyzer FREQUENCY control to center largest response on CRT display.
11. Reduce BANDWIDTH to 1 kHz and SCAN WIDTH PER DIVISION to 2 kHz while keeping signal centered on CRT display.
12. Switch Spectrum Analyzer LOG/LINEAR to LINEAR and adjust sensitivity controls for a full eight division display.
13. Refer to Figure 5-4. Tune FINE TUNE so that the upward slope of the display intersects the CENTER FREQUENCY graticule line one division from the top.

NOTE

The linear portion of the analyzer IF filter skirt is used to slope detect low-order residual FM. The analyzer is stabilized, and the detected FM is displayed in the time domain.

ADJUSTMENTS

5-10. 1.55 GHz Oscillator Residual FM Check (cont'd)

- 14. Note where the slope intersects the middle horizontal graticule line: Horizontal Displacement: _____ divisions
- 15. Use the horizontal displacement to calculate demodulation sensitivity.
 - a. Convert the horizontal displacement(divisions) into Hertz.

Example: (2 kHz SCAN WIDTH) x (0.2 div) = 400 Hz.

- b. Calculate demodulation sensitivity by dividing the vertical displacement in divisions into the horizontal displacement in Hz:

Example: = $\frac{400 \text{ Hz/div}}{3 \text{ divisions}} = 133 \text{ Hz/div}$

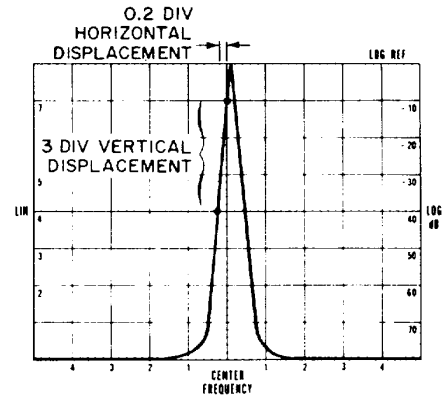

Figure 5-4. Demodulation Sensitivity Measurement

- 16. Turn SCAN WIDTH to ZERO scan. Set FINE TUNE for a response level within the calibrated three division range (one division from the top to the center horizontal graticule line).
- 17. Measure the peak-to-peak deviation, and multiply it by the demodulation sensitivity obtained in step 15b above.

Example: 0.5 div p-p signal deviation x 133 Hz/div = 66.5 Residual FM.

_____ Hz peak-to-peak

- 18. Install cables removed in steps 4 through 6.

ADJUSTMENTS

5-11. First Converter Check and Adjustment

REFERENCE: Service Sheet 3.

DESCRIPTION: The 1.55 GHz oscillator cavity and the two 2.05 GHz IF bandpass cavities in the first converter are adjusted for maximum output signal level. A 8555A Spectrum Analyzer System (8555A/ 8552/140) should be used during the adjustment procedure. In addition to providing the third LO input signal the output signal can be displayed during the adjustment. With the analyzer operating in the linear mode, the cavities are alternately adjusted for maximum indication on the CRT. When only the 8554L Spectrum Analyzer System is available, the output can be monitored using a power meter such as the HP 432B.

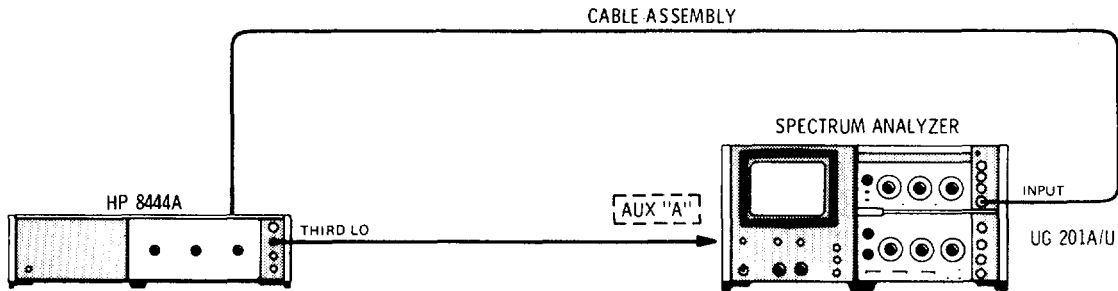

Figure 5-5. First Converter Check and Adjustment Test Setup

EQUIPMENT:

Spectrum Analyzer.....	HP 8555A/8552/141T
Cable Assembly	HP 11592-60001
Adapter	UG 201A/U
Wrench.....	5/16 inch
Allen Driver	No.10

PROCEDURE:

1. Perform 1.55 GHz Oscillator Power Level, Frequency Check and Adjustment, paragraph 5-9.
2. With test setup as indicated in Figure 5-5, set controls as follows:

Tracking Generator

LINE	ON
TRACK ADJ	Centered
LEVEL	0 dBm

Spectrum Analyzer

BAND.....	n=1 - (2.05 GHz IF)
FREQUENCY	500 MHz
BANDWIDTH	100 kHz
SCAN WIDTH PER DIVISION	5 MHz
INPUT ATTENUATION	20 dB
SCAN TIME PER DIVISION	20 MILLISECONDS
LOG REF LEVEL	(+) 10 dBm
LOG/LINEAR	10 dB LOG

ADJUSTMENTS

VIDEO FILTER 10 kHz
 SCAN MODE. INT
 SCAN TRIGGER AUTO

3. Disconnect W6 cable at RF OUT of 500 MHz Amplifier Assembly A4.
4. Connect 11592-60001 cable between A4 RF OUT and Spectrum Analyzer INPUT using UG 201A/U adapter.
5. Record 500 MHz signal level. ≅0 dBm _____
6. Disconnect 11592-60001 cable from A4 RF OUT connector.
7. Install W6 cable removed in step 3 above.
8. Disconnect W9 cable at A5 J3 and connect 11592-60001 cable between A5 J3 and Spectrum Analyzer INPUT.
9. Select Spectrum Analyzer n=1- (550 MHz IF) BAND and adjust FREQUENCY control for dial indication of 2050 MHz.
10. Set Spectrum Analyzer LOG/LINEAR switch to LINEAR and adjust LINEAR SENSITIVITY controls to position signal peak between the 5 and 7 LIN graticule lines.
11. Adjust A5 ADJ 1 (1.55 GHz oscillator cavity) for peak signal indication on CRT display.
12. Alternately adjust A5 ADJ 2 and ADJ 3 (2.05 GHz IF bandpass cavities) for peak signal indication on CRT display.
13. Repeat steps 11 and 12 above.
14. Set Spectrum Analyzer SCAN PER DIVISION to 1 MHz.
15. Tune Tracking Generator TRACK ADJ through its tuning range while observing the CRT display.
16. The passband should be similar to that displayed in Figure 5-6. If not, set TRACK ADJ to center of passband and repeat steps 11 through 15.
17. Set Spectrum Analyzer LOG/LINEAR switch to LOG, measure and record first converter output signal level.
≥-7 dBm _____
18. Install W9 cable between A5 J3 and A6 J2.

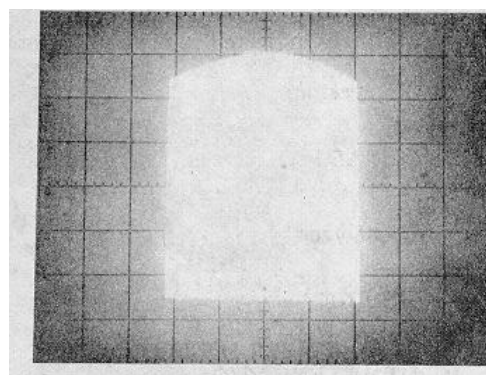

Figure 5-6. First Converter Passband
CR T Display

ADJUSTMENTS

5-12. Automatic Level Control (ALC) Check and Adjustment

REFERENCE: Service Sheet 3.

DESCRIPTION:

The modulator driver functions as an operational amplifier in the ALC loop. A 10 kHz signal is applied to the operational amplifier and the loop gain is adjusted while maintaining 0 dB output level. A limiter in the amplifier circuit is adjusted to prevent a large swing in the driver output when the analyzer sweeps through zero frequency. Perform Level Control Calibration, paragraph 513, after ALC loop adjustment.

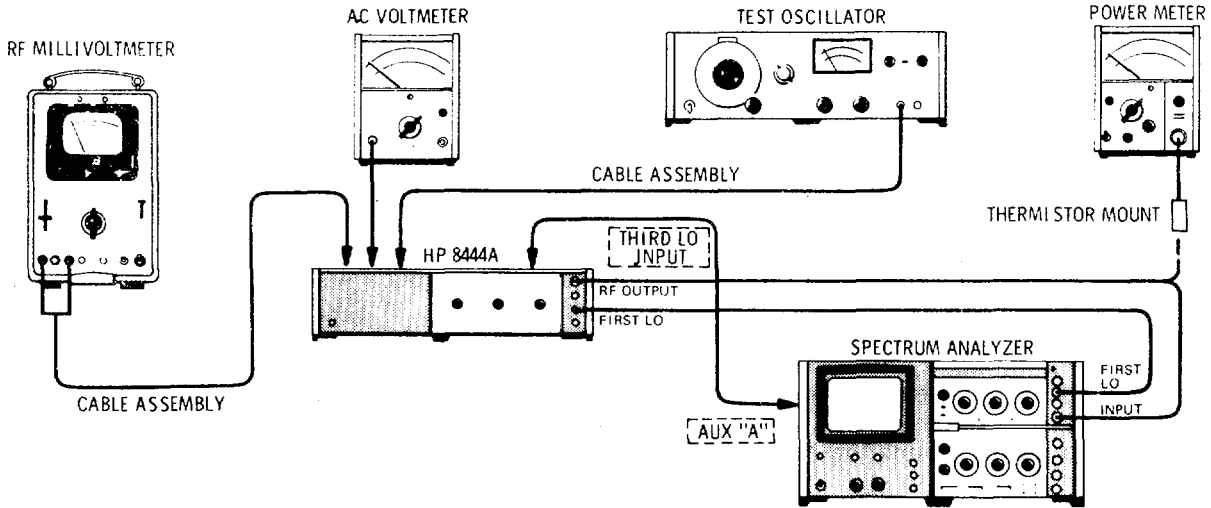

Figure 5-7. Automatic Level Control (ALC) Check and Adjustment Test Setup

EQUIPMENT:

Spectrum Analyzer	HP 8555A/8552/141T
Power Meter	HP 432A
Thermistor Mount	HP 8478B
AC Voltmeter	HP 400E
DC Voltmeter (RF Millivoltmeter)	HP 412A
Test Oscillator	HP 652A
Test Lead with alligator clips	
Cable Assembly	HP 10501A* (2)
Resistor.....	(100K ohm 5%, 1 watt)

*Terminated with alligator clips

PROCEDURE:

1. Perform Spectrum Analyzer calibration procedure; refer to appropriate operation and service manual.
2. Connect test setup as indicated in Figure 5-7 and set controls as follows:

Spectrum Analyzer

BAND.....	n=1 - (2.05 GHz IF)
FREQUENCY	30 MHz
BAND.....	100 kHz
SCAN	ZERO

ADJUSTMENTS**5-12. Automatic Level Control (ALC) Check and Adjustment (cont'd)**

INPUT ATTENUATION	10 dB
TUNING STABILIZER	ON
SIGNAL IDENTIFIER	OFF
BASE LINE CLIPPER	Max CCW
SCAN TIME PER DIVISION	10 MILLISECONDS
LOG REF LEVEL	+10 dBm
LOG/LINEAR	LOG
VIDEO FILTER	OFF
SCAN MODE	INT
SCAN TRIGGER	AUTO

Tracking Generator

LINE	ON
TRACK ADJ	Peak signal indication on CRT
LEVEL	0 dBm

3. Allow instruments to warm up and stabilize for at least 30 minutes.
4. Adjust TRACK ADJ for maximum signal indication on CRT display.
5. Disconnect cable between Tracking Generator RF OUTPUT and Spectrum Analyzer INPUT.
6. Connect Thermistor Mount and Power Meter to Tracking Generator RF OUTPUT.
7. Connect test lead jumper between A2TP1 and A2TP2.
8. Adjust A2R17 "NULL ADJ" for output level of 0 1.0 dBm indication on Power Meter.
9. Remove jumper between A2TP1 and A2TP2.
10. Adjust A2R41 "0 dBm LEVEL" for output level of 0 +0.5 dBm indication on Power Meter.
11. Adjust Test Oscillator for 10 kHz output.
12. Connect Test Oscillator output through 100K ohm resistor to A2TP4.
13. Connect AC Voltmeter to A2TP1.
14. Adjust Test Oscillator output amplitude for an indication of -7 dB (.001 VOLTS RANGE) on AC Voltmeter.
15. Connect AC Voltmeter to A2TP2.
16. Adjust A2R7 "GAIN ADJ" for an indication of -10 dB (.001 VOLTS RANGE) on AC Voltmeter.
17. Adjust A2R17 "NULL ADJ" for Tracking Generator output of 0 dBm.
18. Repeat steps 16 and 17 until both levels are obtained.
19. Disconnect AC Voltmeter and Test Oscillator.
20. Repeat steps 7 through 10 above.
21. Connect DC Voltmeter across A2TP1 and A2TP3, COM to A2TP1 and VOLTS to A2TP3.

ADJUSTMENTS

5-12. Automatic Level Control (ALC) Check and Adjustment (cont'd)

- 22. Adjust A2R6 "LIMIT SET" for an indication of +0.3 Vdc on DC Voltmeter.
- 23. Disconnect DC Voltmeter.
- 24. Perform Level Control Calibration, paragraph 5-13.

5-13. Level Control Calibration Check and Adjustment

REFERENCE: Service Sheet 4.

DESCRIPTION: The level control circuitry is adjusted to provide a 10 dB tuning range of the front panel LEVEL control. The level control circuitry provides the voltage level to the reference diode in the ALC detector. Perform Automatic Level Control Check and Adjustment, paragraph 512, before calibrating the level control.

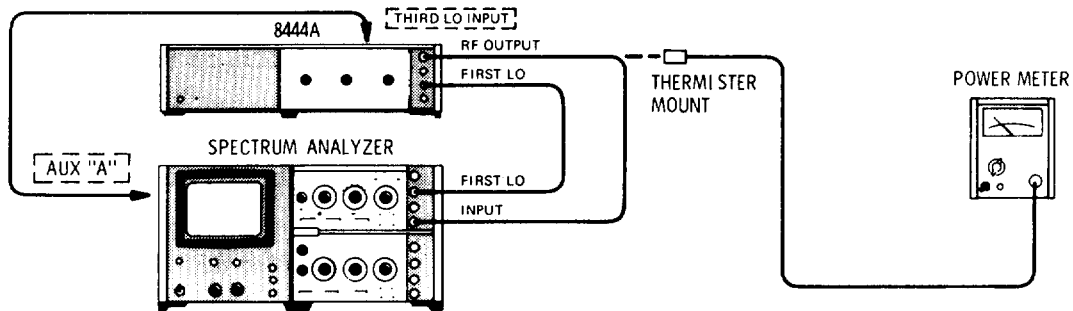

Figure 5-8. Level Control Calibration Check and Adjustment Test Setup

EQUIPMENT:

Spectrum Analyzer	HP 8555A/8552B/141T
Power Meter	HP 432A
Thermistor Mount	HP 8478B

PROCEDURE:

1. Connect test setup as indicated in Figure 5-8 and set controls as follows:

Spectrum Analyzer

BAND.....	n=1 - (2.05 GHz IF)
FREQUENCY	30 MHz
BANDWIDTH	100 kHz
SCAN WIDTH	ZERO
INPUT ATTENUATION	20 dB
TUNING STABILIZER	ON
SIGNAL IDENTIFIER	OFF
BASE LINE CLIPPER	Max CCW
SCAN TIME PER DIVISION.....	10 MILLISECONDS
LOG REF LEVEL	+10 dBm
LOG/LINEAR	LOG

ADJUSTMENTS

5-13. Level Control Calibration Check and Adjustment (cont'd)

VIDEO FILTER OFF
 SCAN MODE INT
 SCAN TRIGGER..... AUTO

Tracking Generator

LINE..... ON
 TRACK ADJ..... Peak signal indication on CRT
 LEVEL OdBm

2. Adjust TRACK ADJ for maximum signal indication on CRT display.
3. Disconnect cable between Tracking Generator RF OUTPUT and Spectrum Analyzer INPUT.
4. Connect Thermistor Mount and Power Meter to Tracking Generator RF OUTPUT.
5. Adjust A2R41 "0 dBm LEVEL" for an indication of 0 ± 0.5 dBm on Power Meter.
6. Set Tracking Generator LEVEL control fully counterclockwise.
7. Adjust A2R40 "-10 dBm LEVEL" for an indication of -10 to -12 dBm on Power Meter.
8. Set Tracking Generator LEVEL control to 0 dBm.
9. Repeat steps 5 through 7 until Power Meter indicates 0 dBm with LEVEL control fully clockwise.
10. Disconnect Power Meter and Thermistor Mount from Tracking Generator RF OUTPUT.
11. Connect cable between Tracking Generator RF OUTPUT and Spectrum Analyzer INPUT.
12. Set Tracking Generator TRACK ADJ for maximum signal level on Spectrum Analyzer CRT display.
13. Note and record signal level at 30 MHz. 0 ± 0.5 dBm

Table 5-1 . Check and Adjustment Test Card

Hewlett-Packard Model 8444A Tracking Generator		Tested by _____			
Serial No. _____		Date _____			
Para. No.	Test Description	Measurement Unit	Min	Actual	Max
5-8	Power Supply, Check and Adjustment				
	+20 Vdc supply	Vdc	+19.98	_____	+20.02
	-10 Vdc supply	Vdc	- 9.5	_____	-10.5
	+20 Vdc supply ripple	μ V		_____	200
	-10 Vdc supply ripple	μ V		_____	200
5-9	1.55 GHz Oscillator Power Level, Frequency Check and Adjustment				
	Power Output	dBm	+5 dBm	_____	
	Frequency Tuning Range	MHz	3.5	_____	4.5
5-10	1.55 GHz Oscillator Residual FM Check				
	Residual FM (peak-to-peak)	Hz		_____	200
5-11	First Converter Check and Adjustment				
	Output Signal Level	dBm	-7	_____	
5-13	Level Control Calibration Check and Adjustment				
	-10 dBm LEVEL position	dBm	-10	_____	-12
	0 dBm LEVEL position	dBm	-0.5	_____	+0.5

SECTION VI REPLACEABLE PARTS

6-1. INTRODUCTION

6-2. This section contains information for ordering parts. Table 6-1 lists abbreviations used in the parts list and throughout the manual. Table 6-2 lists all replaceable parts in reference designator order. Table 6-3 contains names and addresses that correspond to the manufacturer's code numbers.

6-3. ABBREVIATIONS

6-4. Table 6-1 gives a list of abbreviations used in the parts list, schematics, and throughout the manual. In some cases, two forms of the abbreviations are given:

one is in capital letters, while the other is partial or no capitals. This occurs because in the parts list, abbreviations are all capitalized. However, in the schematics and other parts of the manual, other abbreviation forms are used with both lower case and upper case letters.

6-5. REPLACEABLE PARTS LIST

6-6. Table 6-2 is a list of replaceable parts and is organized as follows:

- a. Electrical assemblies and their components in alpha-numerical order by reference designation.
- b. Chassis-mounted parts in alpha-numeric order by reference designation.
- c. Miscellaneous parts.

The information given for each part consists of the following:

- a. The Hewlett-Packard part number.
- b. The total quantity (Qty) used in the instrument.
- c. The description of the part.
- d. The typical manufacturer of the part in a five-digit code.
- e. Manufacturer code number for the part.

The total quantity for each part is given only once - at the first appearance of the part number in the list.

6-7. ORDERING INFORMATION

6-8. To order a part listed in the replaceable parts table, note the Hewlett-Packard part number and then Cross-Reference that part number to the National Stock Number listed in table 6-5. Then order through normal ordering channel 1 s.

6-9. If the part number does not have a National Stock Number, then order through normal ordering channels using the Hewlett-Packard part number.

6-10. Refer to table 6-4 for part number to NSN cross-reference.

Table 6-1. Reference Designations and Abbreviations

REFERENCE DESIGNATIONS

A assembly	E miscellaneous electrical part	P electrical connector (movable portion); plug	U integrated circuit; microcircuit
AT attenuator; isolator; termination	F fuse	Q transistor: SCR; triode thyristor	V electron tube
B fan; motor	FL filter	R resistor	VR voltage regulator; breakdown diode
BT battery	H hardware	RT thermistor	W cable; transmission path; wire
C capacitor	HY circulator	S switch	X socket
CP coupler	J electrical connector (stationary portion); jack	T transformer	Y crystal unit (piezoelectric or quartz)
CR diode; diode thyristor; varactor	K relay	TB terminal board	Z tuned cavity; tuned circuit
DC directional coupler	L coil; inductor	TC thermocouple	
DL delay line	M meter	TP test point	
DS annunciator; signaling device (audible or visual); lamp; LED	MP miscellaneous mechanical part		

ABBREVIATIONS

A ampere	COEF coefficient	EDP electronic data processing	INT internal
ac alternating current	COM common	ELECT electrolytic	kg kilogram
ACCESS accessory	COMP composition	ENCAP encapsulated	kHz kilohertz
ADJ adjustment	COMPL complete	EXT external	k Ω kilohm
A/D analog-to-digital	CONN connector	F farad	kV kilovolt
AF audio frequency	CP cadmium plate	FET field-effect transistor	lb pound
AFC automatic frequency control	CRT cathode-ray tube	F/F flip-flop	LC inductance-capacitance
AGC automatic gain control	CTL complementary transistor logic	FH flat head	LED light-emitting diode
AL aluminum	CW continuous wave	FIL H fillister head	LF low frequency
ALC automatic level control	cm centimeter	FM frequency modulation	LG long
AM amplitude modulation	D/A digital-to-analog	FP front panel	LH left hand
AMPL amplifier	dB decibel	FREQ frequency	LIM limit
APC automatic phase control	dBm decibel referred to 1 mW	FXD fixed	LIN linear taper (used in parts list)
ASSY assembly	dc direct current	g gram	lin linear
AUX auxiliary	deg degree (temperature interval or difference)	GE germanium	LK WASH lock washer
avg average	° degree (plane angle)	GHz gigahertz	LO low; local oscillator
AWG American wire gauge	°C degree Celsius (centigrade)	GL glass	LOG logarithmic taper (used in parts list)
BAL balance	°F degree Fahrenheit	GND ground(ed)	log logarithm(ic)
BCD binary coded decimal	°K degree Kelvin	H henry	LPF low pass filter
BD board	DEPC deposited carbon	h hour	LV low voltage
BE CU beryllium copper	DET detector	HET heterodyne	m meter (distance)
BFO beat frequency oscillator	DIA diameter (used in parts list)	HEX hexagonal	mA milliampere
BH binder head	DIFF AMPL differential amplifier	HD head	MAX maximum
BKDN breakdown	div division	HDW hardware	M Ω megohm
BP bandpass	DPDT double-pole, double-throw	HF high frequency	MEG meg (10 ⁶) (used in parts list)
BPF bandpass filter	DR drive	HG mercury	MET FLM metal film
BRS brass	DSB double sideband	HI high	MET OX metallic oxide
BWO backward-wave oscillator	DTL diode transistor logic	HP Hewlett-Packard	MF medium frequency; microfarad (used in parts list)
CAL calibrate	DVM digital voltmeter	HPF high pass filter	MFR manufacturer
ccw counter-clockwise	ECL emitter coupled logic	HR hour (used in parts list)	mg milligram
CER ceramic	EMF electromotive force	HV high voltage	MHz megahertz
CHAN channel		Hz Hertz	mH millihenry
cm centimeter		IC integrated circuit	mho mho
CMO cabinet mount only		ID inside diameter	MIN minimum
COAX coaxial		IF intermediate frequency	min minute (time)
		IMPG impregnated minute (plane angle)
		in inch	MINAT miniature
		INCD incandescent	mm millimeter
		INCL include(s)	
		INP input	
		INS insulation	

NOTE

All abbreviations in the parts list will be in upper-case.

Table 6-1. Reference Designations and Abbreviations (Cont'd)

MOD modulator	OD outside diameter	PWV peak working voltage	TD time delay
MOM momentary	OH oval head	RC resistance-capacitance	TERM terminal
MOS metal-oxide semiconductor	OP AMPL operational amplifier	RECT rectifier	TFT thin-film transistor
ms millisecond	OPT option	REF reference	TGL toggle
MTG mounting	OSC oscillator	REG regulated	THD thread
MTR meter (indicating device)	OX oxide	REPL replaceable	THRU through
mV millivolt	oz ounce	RF radio frequency	TI titanium
mVac millivolt, ac	Ω ohm	RFI radio frequency interference	TOL tolerance
mVdc millivolt, dc	P peak (used in parts list)	RH round head; right hand	TRIM trimmer
mVpk millivolt, peak	PAM pulse-amplitude modulation	RLC resistance-inductance-capacitance	TSTR transistor
mVp-p millivolt, peak-to-peak	PC printed circuit	RMO rack mount only	TTL transistor-transistor logic
mVrms millivolt, rms	PCM pulse-code modulation; pulse-count modulation	rms root-mean-square	TV television
mW milliwatt	PDM pulse-duration modulation	RND round	TVI television interference
MUX multiplex	pF picofarad	ROM read-only memory	TWT traveling wave tube
MY mylar	PH BRZ phosphor bronze	R&P rack and panel	U micro (10 ⁶) (used in parts list)
μA microampere	PHL Phillips	RWV reverse working voltage	UF microfarad (used in parts list)
μF microfarad	PIN positive-intrinsic-negative	S scattering parameter	UHF ultrahigh frequency
μH microhenry	PIV peak inverse voltage	s second (time)	UNREG unregulated
μmho micromho	pk peak	” second (plane angle)	V volt
μs microsecond	PL phase lock	S-B slow-blow (fuse) (used in parts list)	VA voltampere
μV microvolt	PLO phase lock oscillator	SCR silicon controlled rectifier; screw	Vac volts, ac
μVac microvolt, ac	PM phase modulation	SE selenium	VAR variable
μVdc microvolt, dc	PNP positive-negative-positive	SECT sections	VCO voltage-controlled oscillator
μVpk microvolt, peak	P/O part of	SEMICON semiconductor	Vdc volts, dc
μVp-p microvolt, peak-to-peak	POLY polystyrene	SHF superhigh frequency	VDCW volts, dc, working (used in parts list)
μVrms microvolt, rms	PORC porcelain	SI silicon	V(F) volts, filtered
μW microwatt	PORS positive; position(s) (used in parts list)	SIL silver	VFO variable-frequency oscillator
nA nanoampere	POSN position	SL slide	VHF very-high frequency
NC no connection	POT potentiometer	SNR signal-to-noise ratio	Vpk volts, peak
N/C normally closed	p-p peak-to-peak	SPDT single-pole, double-throw	Vp-p volts, peak-to-peak
NE neon	PP peak-to-peak (used in parts list)	SPG spring	Vrms volts, rms
NEG negative	PPM pulse-position modulation	SR split ring	VSWR voltage standing wave ratio
nF nanofarad	PREAMPL preamplifier	SPST single-pole, single-throw	VTO voltage-tuned oscillator
NI PL nickel plate	PRF pulse-repetition frequency	SSB single sideband	VTVM vacuum-tube voltmeter
N/O normally open	PRR pulse repetition rate	SST stainless steel	V(X) volts, switched
NOM nominal	ps picosecond	STL steel	W watt
NORM normal	PT point	SQ square	W/ with
NPN negative-positive-negative	PTM pulse-time modulation	SWR standing-wave ratio	WIV working inverse voltage
NPO negative-positive zero (zero temperature coefficient)	PWM pulse-width modulation	SYNC synchronize	WW wirewound
NRFR not recommended for field replacement		T timed (slow-blow fuse)	W/O without
NSR not separately replaceable		TA tantalum	YIG yttrium-iron-garnet
ns nanosecond		TC temperature compensating	Z ₀ characteristic impedance
nW nanowatt			
OBDD order by description			

NOTE

All abbreviations in the parts list will be in upper-case.

MULTIPLIERS

Abbreviation	Prefix	Multiple
T	tera	10 ¹²
G	giga	10 ⁹
M	mega	10 ⁶
k	kilo	10 ³
da	deka	10
d	deci	10 ⁻¹
c	centi	10 ⁻²
m	milli	10 ⁻³
μ	micro	10 ⁻⁶
n	nano	10 ⁻⁹
p	pico	10 ⁻¹²
f	femto	10 ⁻¹⁵
a	atto	10 ⁻¹⁸

Table 6-2. Replaceable Parts

Reference Designation	HP Part Number	Qty	Description	Mfr Code	Mfr Part Number
A1	08444-60001	1	BOARD ASSY:POWER SUPPLY	28480	08444-60001
A1C1	0160-3460	2	C:FXD CER 0.05 UF +80-20Z 100VDCW	56289	C023EI06 L503LS22-CDM
A1C2	0180-0116	4	C:FXD ELECT 6.8 UF 10 35VDCW	56289	1500685X903582-DYS
A1C3	0160-2199	2	C:FXO M1CA 30 PF 5% 300VDCW	28480	0160-2199
A1C4	0180-0228	3	C:FXD ELECT 22 UF 105 15VDCW	56289	150D0226X9015B2-DYS
A1C5	0180-0116		C:FXD ELECT 6.8 UF 10% 35VDCW	56289	1500685X903582-DYS
A1C6	0160-3460		C:FXD CER 0.05 UF +80-20Z 100VDCW	56289	C023EI101OL503ZS22-CDM
A1C7	0160-2199		C:FXD 11CA 30 PF 5% 300VDCW	28480	0160-2199
A1C8	0180-0228		C:FXD ELECT 22 UF 10 15VDCW	56289	1500226X901582-DYS
A1C9	0180-0116		C:FXD ELECT 6.8 UF 10% 35VDCW	56289	1500685X903582-DYS
A1CR1	1901-0159	8	DIODE:SILICON 0.75A 400PIV	04713	SR1358-4
A1CR2	1901-0159		DIODE:SILICON 0.75A 400PIV	04713	SR1358-4
A1CR3	1901-0159		DIODE:SILICON 0.75A 400PIV	04713	SR1358-4
A1CR4	1901-0159		DIODE:SILICON 0.75A 400PIV	04713	SR1358-4
A1CR5	1901-0040	5	DIODE:SILICON 30MA 30VV	07263	FDG1088
A1CR6	1901-0200	2	DIODE:SILICON 100 PIV 3A	02735	1N4998
A1CR7	1901-0200		DIODE:SILICON 100 PIV 3A	02735	1N4998
A1CR8	1902-3182	1	DIODE BREAKDOWN:SILICON 12.1V 5%	28480	1902-3182
A1CR9	1902-3256	1	DIODE:BREAKDOWN SILICON 23.78 5%	28480	1902-3256
A1CR10	1884-0012	1	RECTIFIER:SILICON CONTROLLED 2N3528	02735	2N3528
A1CR11	1902-0761	1	DIODE:BREAKDOWN 5.9 TO 6.5V	12954	1N821
A1CR12	1901-0159		DIODE:SILICON 0.75A 400PIV	04713	SR1358-4
A1CR13	1901-0156		DIODE:SILICON 0.75A 400IV	04713	SR1358-4
A1CR13	1901-0159		DIODE:SILICON 0.75A 400PIV	04713	SR1358-4
A1CR14	1901-0159		DIODE:SILICON 0.75A 400PIV	04713	SR1358-4
A1CR15	1901-0159		DIODE:SILICON 0.75A 400PIV	04713	SR1358-4
AiCR16	1901-0040		DIODE:SILICON 30MA 30VV	07263	FDG1088
A1F1	2110-0012	2	FUSE:0.5 AMP 250V	75915	312.500
A1F2	2110-0012		FUSE:0.5 AMP 250V	75915	312.500
A1MP1	2110-0269	4	CL1P:FUSE 0.250" DIA	91506	6008-32CN
A1MP2	2110-0269		CL1P:FUSE 0.250" DIA	91506	6008-32CN
A1MP3	2110-0269		CLIP:FUSE 0.250" D1A	91506	6008-32CN
A1MP4	2110-0269		CLIP:FUSE 0.250" D1A	91506	6008-32CN
A1Q1	1853-0020	7	TSTR:SI PNP(SELECTED FROM 2N3702)	28480	1853-0020
A1Q2	1853-0012	2	TSTR:SI PNP	80131	2N2904A
A1Q3	1854-0039	2	TSTR:SI NPN	80131	2N3053
A1Q4	1854-0071	3	TSTR:SI NPN(SELECTED FROM 2N3704)	28480	1854-0071
A1Q5	1853-0020		TSTR:SI PNP(SELECTED FROM 2N3702)	28480	1853-0020
A1Q6	1854-0039		TSTR:SI NPN	80131	2N3053
A1Q7	1854-0071		TSTR:SI NPN(SELECTED FROM 2N3704)	28480	1854-0071
A1R1	0698-3160	2	R:FXD MET FLM 31.6K OHM 1% 1/8W	28480	0698-3160
A1R2	0698-3445	2	R:FXD MET FLM 348 OHM 1X 1/8W	28480	0698-3445
A1R3	0757-0440	4	R:FXD MET FLM 7.50K OHM 1t 1/8W	28480	0757-0440
A1R4	0811-1666	2	R:FXD MWW 1.0 OHM 5% 2W	28480	0811-1666
A1R5	0698-3441	4	R:FXD MET FLM 215 OHM 12 1/8W	28490	0698-3441
A1R6	0157-0440		R:FXD MET FLM 7.50K OHM 1% 1/8W	28480	0757-0440
A1R7	0757-0280	5	R:FXD MET FLM 1K OHM 1% 1/8W	28480	0757-0280
A1R8	0757-0401	3	R:FXD MET FLM 100 OHM 1% 1/8W	28480	0757-0401
1AR9	0757-0438	3	R:FXD MET FLM 5.11K OHM 1% 1/8W	28480	0757-0438
A1R10	0683-0275	2	R:FXD COMP 2.7 OHM 52 1/4W	01121	CB 27G5
A1R11	0757-0280		R:FXD MET FLM LK OHM 1% 1/8W	28480	0757-0280
ALR12	0757-0278	1	R:FXD MET FLM 1.78K OHM 1% 1/8W	28480	0757-0278
A1R13	0757-0289	1	R:FXD MET FLM 13.3K OHM 3 1/81W	28480	0757-0289
A1R14	2100-1758	3	R:VAR WW 1K OHM 53 TYPE V 1W	28480	2100-1758
A1R15	0757-0200	1	R:FXO MET FLM 5.62K OHM 1% 1/8W	28480	0757-0200
A1RL16	0811-1666		R:FXD WW 1.0 OHM 5% 2W	28480	0811-1666
A1R17	0698-3441		R:FXD MET FLM 215 OHM 1% 1/8W	28480	0698-3441
A1R18	0757-0440		R:FXD MET FLM 7.50K OHM 1% 1/8W	28480	0757-0440
1AR19	0757-0280		R:FXD MET FLM 1K OHM 1% 1/8W	28480	0757-0280
A1R20	0757-0440		R:FXD MET FLM 7.50K OHM 1% 1/8W	28480	0757-0440
A1R21	0698-0084	3	R:FXD MET ELM 2.15K OHM 1% 1/8W	28480	0698-0084
A1R23	0698-0084		R:FXD MET FLM 2.15K OHM 1% 1/8W	28480	0698-0084
A1R22	0698-0084		R:FXD MET FLM 2.15K OHM 1% 1/8W	28480	0698-0084
A1R24	0683-0275		R:FXD COMP 2.7 OHM 5% 1/4W	01121	CB 27G5
A1TB1	08444-20001	1	BOARD:BLANK PC	28480	08444-20001
A1TP1	0360-1514	12	TERMINAL PIN:SQUARE	28480	0360-1514
A1TP2	0360-1514		TERMINAL PIN:SQUARE	28480	0360-1514
A1TP3	0360-1514		TERMINAL PIN:SQUARE	28480	0360-1514
A1TP4	0360-1514		TERMINAL PIN:SQUARE	28480	0360-1514
A1TP5	0360-1514		TERMINAL PIN:SQUARE	28480	0360-1514
A1LT6	0360-1514		TERMINAL PIN:SQUARE	28480	0360-1514
A1U1	1820-0223	3	INTEGRATED CIRCUIT:OPERATIONAL AMPL.	28480	1820-0223
A1U2	1820-0223		INTEGRATED CIRCUIT:OPERATIONAL AMPL.	28480	1820-0223
A2	08444-60002	1	BOARD ASSY:DRIVER	28480	08444-60002
A2C1	0180-0116		C:FXO ELECT 6.8 UF 10% 35VDCW	56289	150D685X903582-DYS
A2C2	0180-2205	1	C:FXD ELECT 0.33 UF 10% 35VDCW	56289	1500334X9035A2-DYS

Table 6-2. Replaceable Parts

Reference Designation	HP Part Number	Qty	Description	Mfr Code	Mfr Part Number
A2C3	0180-0228		C:FXD ELECT 22 UF 10% 15VDCW	56289	1500226X901582-DYS
A2C4	0180-1746	1	C:FXD ELECT 15 UF 10% 20VDCW	28480	0180-1746
A2C5	0180-0374	2	C:FXD TANT. 10 UF 10% 20VDCW	56289	1500106X902082-DYS
A2C6	0160-2208	1	C:FXD MICA 330 PF 5% 300VDCW	28480	0160-2208
A2C7	0180-0374		C:FXD TANT. 10 UF 10% 20VDCW	56289	1500106X902082-DYS
A2C8	0160-0300	1	C:FXD MY 0.0027 UF 10% 200VDCW	56289	292P27292-PTS
A2CR1	1901-0040		DIODE:SILICON 30MA 30WV	07263	FDG1088
A2CR2	1901-0040		DIOOE:SILICON 30MA 30WV	07263	FDG1088
A2CR3	1901-0040		DIODE:SILICON 30MA 30WV	07263	FDG1088
A2Q1	1854-0221	1	TSTR:SI NPN(REPL.BY 2N4044)	28480	1854-0221
A2Q2	1853-0020		TSTR:SI PNP(SELECTED FROM 2N3702)	28480	1853-0020
A2Q3	1853-0020		TSTR:SI PNP(SELECTED FROM 2N3702)	28480	1853-0020
A2Q4	1853-0020		TSTR:SI PNP(SELECTED FROM 2N3702)	28480	1853-0020
A2Q5	1853-0020		TSTR:SI PNP(SELECTED FROM 2N3702)	28480	1853-0020
A2Q6	1854-0071		TSTR:SI NPN(SELECTED FROM 2N3704)	28480	1854-0071
A2Q7	1853-0020		TSTR:SI PNP(SELECTED FROM 2N3702)	28480	1853-0020
A2Q8	1853-0012		TSTR:SI PNP	80131	2N2904A
A2R1	0757-0346	3	R:FXD MET FLM 10 OHM 1% 1/8W	28480	0757-0346
A2R2	0698-3454	2	R:FXD MET FLM 215K OHM 1% 1/8W	28480	0698-3454
A2R3	0757-0280		R:FXD MET FLM 1K OHM 1% 1/8W	28480	0757-0280
A2R4	0757-0280		R:FXO MET FLM 1K OHM 1% 1/8W	28480	0757-0280
A2R5	0757-0438		R:FXO MET FLM 5.11K OHM 1% 1/8W	28480	0757-0438
A2R6	2100-1760	3	R:VAR WW 5K OHM 5% TYPE V 1W	28480	2100-1760
A2R7	2100-1760		R:VAR WW 5K OHM 5% TYPE V 1W	28480	2100-1760
A2R8	0698-3444	1	R:FXD MET ELM 316 OHM 1% 1/8W	28480	0698-3444
A2R9	0698-3156	1	R:FXD MET FLM 14.7K OHM 1% 1/8W	28480	0698-3156
A2R10	0757-0346		R:FXD MET FLM 10 OHM 1% 1/8W	28480	0757-0346
A2R11	0698-3154	1	R:FXD MET FLM 4.22K OHM 1% 1/8W	28480	0698-3154
A2R12	0757-0346		R:FXD MET FLM 10 OHM 1% 1/8W	28480	0757-0346
A2R13	0698-3454		R:FXD MET FLM 215K OHM 1% 1/8W	28480	0698-3454
A2R14	0757-0424	2	R:FXD MET FLM 1.10K OHM 1% 1/8W	28480	0757-0424
A2R15	0698-3437	1	R:FXD MET FLM 133 OHM 1% 1/8W	28480	0698-3437
A2R16	0757-0817	1	R:FXD MET FLM 750 OHM 1% 1/2W	28480	0757-0817
A2R17	2100-1758		R:VAR WW 1K OHM 5% TYPE V 1W	28480	2100-1758
A2R18	0698-3445		R:FXD MET ELM 348 OHM 1% 1/8W	28480	0698-3445
A2R19	0757-0401		R:FXD MET FLM 100 OHM 1% 1/8W	28480	0757-0401
A2R20	0757-0416	1	R:FXD MET FLM 511 OHM 1% 1/8W	28480	0757-0416
A2R21	0698-3450	1	R:FXD MET FLM 42.2K OHM 1% 1/8W	28480	0698-3450
A2R22	0757-0401		R:FXD MET FLM 100 OHM 1% 1/8W	28480	0757-0401
A2R23	0757-1094	1	R:FXD MET ELM 1.47K OHM 1% 1/8W	28480	0757-1094
A2R24	0757-0424		R:FXD MET FLM 1.10K OHM 1% 1/8W	28480	0757-0424
A2R25	0698-3441		R:FXD MET FLM 215 OHM 1% 1/8W	28480	0698-3441
A2R26	2100-2522	1	R:VAR CERMET 10K OHM 10% LIN 1/2W	28480	2100-2522
A2R27	2100-1758		R:VAR WW 1K OHM 5% TYPE V 1W	28480	2100-1758
A2R28	0757-0442	4	R:FXD MET FLM 10.0K OHM 1% 1/8W	28480	0757-0442
A2R29	0757-0465		R:FXD MET FLM 100K OHM 1% 1/8W	28480	0757-0465
A2R30	0757-0288	2	R:FXD MET FLM 9.09K OHM 1% 1/8W	28480	0757-0288
A2R31	0757-0442		R:FXD MET FLM 10.0K OHM 1% 1/8W	28480	0757-0442
A2R32	0757-0438		R:FXD MET FLM 5.11K OHM 1% 1/8W	28480	0757-0438
A2R33	0698-3441		R:FXD MET FLM 215 OHM 1% 1/8W	28480	0698-3441
A2R34	0757-0442		R:FXD MET FLM 10.0K OHM 1% 1/8W	28480	0757-0442
A2R35	0698-3399	1	R:FXD MET FLM 133 OHM 1% 1/2W	28480	0698-3399
A2R36	0757-0439		R:FXD MET FLM 6.81K OHM 1% 1/8W	28480	0757-0439
A2R37	0757-0421	1	R:FXD MET ELM 825 OHM 1% 1/8W	28480	0757-0421
A2R38	0698-3438	1	R:FXD MET FLM 147 OHM 1% 1/8W	28480	0698-3438
A2R39	0757-0288		R:FXD MET FLM 9.09K OHM 1% 1/8W	28480	0757-0288
A2R40	2100-2522	1	R:VAR WW 10K OHM 10% TYPE V 1W	19701	ET50X103
A2R41	2100-1760		R:VAR WW 5K OHM 5% TYPE V 1W	28480	2100-1760
A2R42	0698-3151	1	R:FXD MET FLM 2.87K OHM 1% 1/8W	28480	0698-3151
A2TB1	08444-20002	1	BOARD:BLANK PC	28480	08444-20002
A2TP1	0360-1514		TERMINAL PIN:SQUARE	28480	0360-1514
A2TP2	0360-1514		TERMINAL PIN:SQUARE	28480	0360-1514
A2TP3	0360-1514		TERMINAL PIN:SQUARE	28480	0360-1514
A2TP4	0360-1514		TERMINAL PIN:SQUARE	28480	0360-1514
A2TP5	0360-1514		TERMINAL PIN:SQUARE	28480	0360-1514
A2TP6	0360-1514		TERMINAL PIN:SQUARE	28480	0360-1514
A2UI	1820-0223		INTEGRATED CIRCUIT:OPERATIONAL AMPL.	28480	1820-0223
A3	5086-7025	1	AMPLIFIER DETECTOR	28480	0960-2038
A3			NOT FIELD REPAIRABLE		
A4			AMPLIFIER ASSY:500 MHZ		
A4C1	0160-2357	2	C:FXD CER FEED-THRU 1000 PF +80-20%	28480	0160-2357
A4C2	0160-2357		C:FXD CER FEED-THRU 1000 PF +80-20%	28480	0160-2357
A4C3	0160-2152	1	C:FXD CER 10 PF 20% 500VDCW	28480	0160-2152
A4J1	1250-1220	2	CONNECTOR:RF 50 OHM SCREW-ON TYPE	98291	50-051-0109
A4J2	1250-1220		CONNECTOR:RF 50 OHM SCREW-ON TYPE	98291	50-051-0109

Table 6-2. Replaceable Parts

Reference Designation	HP Part Number	Qty	Description	Mfr Code	Mfr Part Number
A4MP1	08444-00006	1	COVER:500 MHZ AMPLIFIER	28480	08444-00006
A4MH2	08444-20011	1	HOUSING:500 MHZ AMPLIFIER	28480	08444-20011
A4A1	08444-60005	1	BOARD ASSY:500 MHZ AMPLIFIER	28480	08444-60005
A4A1C1	0160-2266	11	C:FXD CER 24 PF 5% 500VDCW	72982	301-000-COGO-240J
A4A1C2	0160-3456		C:FXD CER 1000 PF 10% 250 VDCW	28480	0160-3456
A4A1C3	0160-2266		C:FXD CER 24 PF 5% 500VDCW	72982	301-000-COGO-240J
A4A1C4	0160-2266		C:FXD CER 24 PF 5% 500VDCW	72982	301-000-COGO-240J
A4A1C5	0160-2266		C:FXD CER 24 PF 5% 500VDCW	72982	301-000-COGO-240J
A4A1C6	0160-2266		C:FXD CER 24 PF 5% 500VDCW	72982	301-000-COGO-240J
A4A1C7	0160-2266		C:FXO CER 24 PF 5% 500VDCW	72982	301-000-COGO-240J
A4A1C8	0160-2266		C:FXD CER 24 PF 500VDCW	72982	301-000-COGO-240J
A4A1C9	0160-2266		C:FXD CER 24 PF 500VDCW	72982	301-000-COGO-240J
A4A1C10	0160-2266		C:FXD CER 24 PF 500VDCW	72982	301-000-COGO-240J
A4A1C11	0160-2266		C:FXD CER 24 PF 500VDCW	72982	301-000-CG000-240J
A4A1CR1	1901-0639	2	DIOOE:PIN 1MHZ TO 1GHZ	28480	1901-0639
A4A1CR2	1901-0639		DIOOE:PIN 1MHZ TO 1GHZ	28480	1901-0639
A4A1L1	9100-2252	4	COIL/CHOKE 0.27 UH 10%	28480	9100-2252
A4A1L2	9100-2252		COIL/CHOKE 0.27 UH 10%	28480	9100-2252
A4A1L3	9100-2252		COIL/CHOKE 0.27 UH 10%	28480	9100-2252
A4A1L4	9100-2252		COIL/CHOKE 0.27 UH 10%	28480	9100-2252
A4A1Q1	1854-0345	3	TSTR:SI NPN	80131	2N5179
A4A1Q2	1854-0345		TSTR:SI NPN	80131	2N5179
A4A1Q3	1854-0345		TSTR:SI NPN	80131	2N5179
A4A1R1	0698-7197	1	R:FXD FLM 23.7 OHM 2% 1/8W	28480	0698-7197
A4A1R2	0698-7236	9	R:FXD FLM 1K OHM 2% 1/8W	28480	0698-7236
A4A1R3	0698-7236		R:FXD FLM 1K OHM 2% 1/8W	28480	0698-7236
A4A1R4	0698-7236		R:FXD FLM 1K OHM 2% 1/8W	28480	0698-7236
A4A1R5	0698-7236		R:FXD FLM 1K OHM 2% 1/8W	28480	0698-7236
A4A1R6	0698-7236		R:FXD FLM 1K OHM 2% 1/8W	28480	0698-7236
A4A1R7	0698-7236		R:FXD FLM 1K OHM 2% 1/8W	28480	0698-7236
A4A1R8	0698-7236		R:FXD FLM 1K OHM 2% 1/8W	28480	0698-7236
A4A1R9	0698-7236		R:FXD FLM 1K OHM 2% 1/8W	28480	0698-7236
A4A1R10	0698-7236		R:FXD FLM 1K OHM 2% 1/8W	28480	0698-7236
A4A1R11	0693-7214	1	R:FXD FLM 121 OHM 2% 1/8W	28480	0698-7214
A4A1TB1	08444-20005	1	BOARD:BLANK PC	28480	08444-20005
A5	08444-60011	1	CONVERTER ASSY:FIRST	28480	08444-60011
A5J1	1250-0829	5	CONNECTOR:RF 50-OHM SCREW ON TYPE	98291	50-045-4610
A5J2	1250-0829		CONNECTOR:KF 50-OHM SCREW ON TYPE	98291	50-045-4610
A5J3	1250-0829		CONNECTOR:RF 50-OHM SCREW ON TYPE	98291	50-045-4610
A5MP1	08555-00033	2	INPUT-OUTPUT LOOP	28480	08555-00033
A5MP2	0516-0005	2	SCREW:PAN HD SLOT DR 0-80 X 0.188" LG	00000	080
A5MP3	2200-0111	14	SCREW:PAN HD POLI DR 4-40 X 0.500" LG	00000	OBD
A5MP4	08555-20035	1	CAVITY BLOCK:SECOND CONVERTER	28480	08555-20035
A5MP5	08444-20012	1	COVER:FIRST CONVERTER	28480	08444-20012
A5MP6	2200-0172	2	SCREW:FLAT HD POZI DR 4-40 X 0.875" LG	00000	OBD
A5MP7	08444-20007	1	CENTER-POST	28480	08444-20007
A5MP8	2740-0001	3	NUT:HEX 10-32 THREAD	00000	O8D
A5MP9	3030-0151	4	SCREW:SOCKET CAP 4-40 THREAD	28480	3030-0151
A5MP10	3030-0397	3	SCREW:SET 10-32 UNF-2A THREAD	00000	OBD
A5A1	08444-60012	1	MIXER ASSY:FIRST	28480	08444-60012
A5A1C1	0160-2327	1	C:FXO CER 1000 PF 20% 100VDCW	96733	B104BX102M
A5A1C2	0160-3861	1	C FXD 18 PF + -5% 250 VDCW	72982	2930-000-3903
A5A1C3	0160-3860	1	C:FXD MICA 39 PF 5% 250VDCW	72982	2930-000-390J
A5A1CR1	1901-0633	1	DIODE:HOT CARRIER	28480	1901-0633
A5A1J1	1250-0829		CONNECTOR:RF 50-OHM SCREW ON TYPE	98291	50-045-4610
A5A1L1	9100-2254	1	COIL/CHOKE .39 UH 10%	28480	9100-2254
A5A1MP1	0520-0128	4	SCREW:PAN HD POZI DR 2-56 X 0.250" LG	00000	OBD
A5A1MP2	1251-1556	1	CONNECTOR:SINGLE CONTACT	00779	2-330808-8
A5A1MP3	08555-00031	1	LID:RESONATOR HOUSING	28480	08555-00031
A5A5MP4	0855-20036	1	RESONATOR HOUSING	28480	08555-20016
A5A1R1	0698-7233	1	R:FXD FLM 750 OHM 2% 1/8W	28480	0698-7233
A6	08444-60004	1	MIXER ASSY:OUTPUT	28480	08444-60004
A6			NOT RECOMMENDED FOR FIELD REPAIR		
A7	08444-60019	1	OSCILLATOR ASSY:1.55 GHZ		
A7			NOT RECOMMENDED FOR FIELD REPAIR	28480	08444-60019
A7C1	0163-3827*	1	C:FXD PRC 1 PF 500VDCW	84411	663UW22354W2
A7C2	0160-0345	2	C:FXD CEP FEED-THRU 1000 PF 500VDCW	01121	FB2B-102W
A7C3	0160-0345		C:FXD CER FEED-THRU 1000 PP 500VDCW	01121	FB2B-102W
A7C4	0160-2437	1	C FXD CER 5000 PF +80 -20%		
A7CR1	0122-0245	2	C:VOLTAGE VAR. 6.8 PF 10% 60VDCW	04713	1N5139
A7J1	1250-0829		CONNECTOR:KF 5-OHM SCREW ON TYPE	98291	50-045-4610
A7L1	1460-0103	1	SPRING:COMPRESSION 0.120" OD	00000	O8D
A7Q1	1854-0292	1	TSTR:SI NPN	28480	1854-0292
A7R1	0698-7230	1	R:FXD FLM 562 OHM 2% 1/8W	28480	0698-7230
A7R2	0757-0418	1	R:FXD MET FLM 619 OHM 1% 1/8W	28480	0757-0418
A8	5060-1189		POWER LINE MODULE. NON-FILTERED	28480	5060-1189

Table 6-2. Replaceable Parts

Reference Designation	HP Part Number	Qty	Description	Mfr Code	Mfr Part Number
CHASSIS PARTS					
AT1	0960-0084	2	ISOLATOR:2-PORT 2-4 GHZ	28480	0960-0084
AT2	0960-0084		ISOLATOR:2-PORT 2-4 GHZ	28480	0960-0084
AT3	0960-0168	1	ISOLATOR:2-PORT 1.54-1.56 GHZ	28480	0960-0168
AT4	11593A	1	TERMINATION:50 OHM	28480	11593A
C1	0180-2181	2	C:FXD ELECT 1300 UF +75-10% 50VDCW	56289	3601320050AA2A-DQ8
C1	1210-0013	2	BRACKET:MOUNTING FOR 1-3/8 OD	56289	4586-87A
C2	0180-2181		C:FXD ELECT 1300 UF +75-10% 50VDCW	56289	3601320050A02A-DQB
C2	1210-0013		BRACKET:MOUNTING FOR 1-3/8 OD	56289	4586-87A
C3	0160-0155	1	C:FXD MY 0.0033 UF 10% 200VDCW	28080	0160-0155
CP1	1250-0838	1	CONNECTOR:RF ADAPTER TEE	98291	50-085-0000
F1	2110-0202	1	FUSE:0.50A 250V SLOW-BLOW (FOR 115V OPERATION)	75915	313.500S
F1	2110-02011		FUSE:0.25A 250V SLO-BLO (FOR 230V OPERATION)	71400	MDL-1/4
FL1			FILTER:TUBULAR BANDPASS 2.0-3.4 GHZ	28480	0960-0167
J1MPI	1250-0914	1	BODY:RF CONNECTOR	02660	131-150
J1MP2	1250-0915	1	CONTACT:RF CONNECTOR	02660	131-149
J1MP3	5040-0306	1	INSULATOR	28480	5040-0306
J1M4	08555-20093	1	CONTACT:JACK	28480	08555-20093
J1MP5	08555-20094	1	BODY:BULKHEAD	28480	08555-20094
J1MP6	2190-0444	1	WASHER:LOCK	00000	O8D
J1MP7	2950-0132	1	NUT:HEX 7/16-28	00000	O8D
J1MP8	08761-2027	1	INSULATOR	28480	08761-2027
J4	1250-0118	1	CONNECTOR:BNC	24931	28JR 128-1
J6	1251-2996	1	CONNECTOR:AC POWER	28480	1251-2996
Q1	1854-0063	2	TSTR:SI NPN	80131	2N3055
Q1	1200-0043	2	INSULATOR:TSTR MOUNTING(TO-3)	17185	293011
Q2	1854-0063		TSTR:SI NPN	80131	2N3055
Q2	1200-0043		INSULATOR:TSTR MOUNTING(TO-3)	17185	293011
R1	2100-2730	1	R:VAR CERMET 5000 OHM 20% LIN 2W	28480	2100-2730
R1	0370-0133	3	KNOB:SKIRTED FOR 0.250" DIA SHAFT	28480	0370-0133
R2	2100-2886	1	R:VAR WW 5K OHM 5% LIN 2W	28480	2100-2886
R2	0370-0133		KNOB:SKIRTED FOR 0.250" DIA SHAFT	28480	0370-0133
R3	2100-2728	1	R:VAR CERNET 1K OHM 20% LIN 2W	28480	2100-2728
R3	0370-0133		KNOB:SKIRTED FOR 0.250" DIA SHAFT	28480	0370-0133
R4	0698-3449	1	R:FXD MET FLM 28.7K OHM 1% 1/8W	28480	0698-3449
R5	0757-3438	1	R FXD MET FLM 5.11 OHM 1% 1/8W	28080	0757-0438
S1	3101-1248	1	SWITCH:PUSHBUTTON SPDT ILLUMINATED	87034	53-55480-121/A1H
S1DS1	2140-0244	1	LAMP:GLOW MINIATURE 95V	87034	A1H
W1	08444-20018	1	CABLE ASSY:FIRST LO INPUT	28480	08444-20018
W2	08444-20024	2	CABLE ASSY:FILTER	28480	08444-20024
W3	08444-20024		CABLE ASSY:FILTER	28480	08444-20024
W4	08444-20020	1	CABLE ASSY:MIXER ISOLATOR	28480	08444-20020
W5	08444-60015	1	CABLE ASSY:THIRD LO INPUT	28480	08444-60015
W6	08444-60014	1	CABLE ASSY:FIRST CONVERTER	28480	08444-60014
w7	08444-20017	1	CABLE ASSY:OSCILLATOR	28480	08444-20017
W8	08444-20026	1	CABLE ASSY:FIRST ISOLATOR	28480	08444-20026
W9	09444-20027	1	CABLE ASSY:FIRST C OUTPUT	28480	08444-20027
W10	08444-20021	1	CABLE ASSY:MIXER-CIRCUIT	28480	08444-20021
W11	08444-20019	1	CABLE ASSY:RF OUTPUT(AUXILIARY)	28480	0844O 20019
W12	08444-20023	1	CABLE ASSY:RF OUTPUT	28480	08444-20023
W13	08444-60016	1	CABLE ASSY:THIRD LO INPUT	28480	08444-60016
W14	08444-60018	3	CABLE ASSY:RF INTERCONNECT	28480	08444-60018
W15	0R444-60018		CABLE ASSY:RF INTERCONNECT	28480	08444-60018
W16	08444-60018		CABLE ASSY:RF INTERCONNECT	28480	08444-60018
W17	08444-60017	1	CABLE ASSY:INTERCONNECTING	28480	08444-60017
W18	8120-1348	1	CABLE:LINE POWER	28480	8120-1348
XA1	1251-0159	1	CONNECTOR:PC EDGE 2 X 15 CONTACT	71785	251-15-30-261
XA2	1251-0135	1	CONNECTOR:PC EDGE 15 CONTACT	95354	91-6915-1500-00
XF1	1400-0011	2	CLIP:FUSE	75915	#125002
XF1	1400-0011		CLIP:FUSE	75915	#125002
XQ1	1200-0041	2	SOCKET:TRANSISTOR	71785	133-32-10-013
XQ2	1200-0041		SOCKET:TRANSISTOR	71785	133-32-10-013
	08444-60013	1	WIRING HARNESS	28480	08444-60013
T1	9100-3308	1	TRANSFORMER: POWER 115-230 VAC 48-440 HZ	28480	9100-3308

Table 6-2. Replaceable Parts

Reference Designation	HP Part Number	Qty	Description	Mfr Code	Mfr Part Number
			MECHANICAL PARTS		
MP1	1490-0030	1	STAND:TILT	28480	1490-0030-
MP2	5000-0050	2	TRIM:SIDES	28480	5000-0050
MP3	5000-0730	2	COVER:SIDE 3 X 16(BLUE GRAY)	28480	5000-0730
MP3	5000-8593	2	COVER:SIDE 3 X 16(OLIVE GRAY)	28480	5000-8593
MP4	5020-0900	1	TRIM:PANEL(LIGHT GRAY)	28480	5020-0900
MP4	5020-6850	1	TRIM:PANEL(MINT GRAY)	28480	5020-6850
MP5	5020-0901	1	TRIM:PANEL(LIGHT GRAY)	28480	5020-0901
MP5	5020-6851	1	TRIM:PANEL(MINT GRAY)	28480	5020-6851
MP6	5040-0170	4	GUIDE:PLUG-IN PC BOARD	28480	5040-0170
MP7	5060-0730	2	FRAME ASSY:3 X 16	28480	5060-0730
MP8	5060-0740	1	COVER ASSY:TOP 16L(BLUE GRAY)	28480	5060-0740
MP8	5060-8589	1	COVER ASSY:TOP 16L(OLIVE GRAY)	28480	5060-8589
MP9	5060-0752	1	COVER ASSY:BOTTOM 16L(BLUE GRAY)	28480	5060-0752
MP9	5060-8713	1	COVER:BOTTOM	28480	5060-8713
MP10	5060-0767	5	FOOT ASSY:FM	28480	5060-0767
MP11	5060-0774	1	RACK MOUNTING KIT:3H (LIGHT GRAY)	28480	5060-0774
MP11	5060-8739	1	KIT:RACK MOUNT 3H (MINT GRAY)	28480	5060-8739
MP12	08443-40002	1	TRIM STRIP(LIGHT GRAY)	28480	08443-40002
MP12	08443-40005	1	TRIM STRIP(MINT GRAY)	28480	08443-40005
MP13	08444-00001	1	PANEL:FRONT(BLACK/LIGHT GRAY)	28480	08444-00001
MP13	08444-00013	1	PANEL:FRONT(OLIVE BLACK/MINT GRAY)	28480	08444-00013
MP14	08444-00002	1	PLATE:CONNECTOR	28480	08444-00002
MP14	08444-00015	1	PLATE:CONNECTOR(OLIVE BLACK)	28480	08444-00015
MP15	09444-00003	1	DECK:MAIN	28480	08444-00003
MP16	08444-00004	1	PANEL:REAR	28480	08444-00004
MP17	09444-00007	1	GUARD	28480	08444-00007
MP18	08445-00008	4	CLAMP:FRONT PANEL TRIM	28480	08445-00008

Table 6-3. Code List of Manufacturers

MFR NO.	MANUFACTURER NAME	ADDRESS	ZIP CODE
00000	U.S.A. COMMON	ANY SUPPLIER OF U.S.A.	
00779	AMP INC.(AIRCRAFT MARINE PROD.)	HARRISBURG, PA.	17101
01121	ALLEN BRADLEY CO.	MILWAUKEE, WIS.	53204
03553	AMPHENOL CORP.	BRDADVIEW, ILL.	60153
02735	RCA SOLID STATE & RECEIVING TUBE DIV.	SOMERVILLE, N.J.	08876
04713	MOTOROLA SEMICONDUCTOR PROD. INC.	PHOENIX, ARIZ.	85008
07203	FAIRCHILD CAMEPA & INST. CORP. SEMICONDUCTOR DIV.	MOUNTAIN VIEW, CALIF.	94040
12954	DICKSON ELECTRONIC CORP.	SCOTTSDALE, ARIZ.	85252
24931	SPECIALTY CONNECTOR CO. INC.	INDIANAPOLIS, IND.	46227
28480	HEWLETT-PACKARD COMPANY	PALO ALTO, CALIF.	94304
56289	SPRAGUE ELECTRIC CO.	N. ADAMS, MASS.	01247
71400	BUSSMANN MFG. DIV. MC GRAW-EDISON CO.	ST. LOUIS, MO.	63017
71785	CINCH MFG. CO. DIV TRW INC.	ELK GROVE VILLAGE, ILL.	
72982	ERIE TECHNOLOGICAL PROD. INC.	ERIE, PA.	16512
75915	LITTELFUSE INC.	DES PLAINES, ILL.	60016
80131	ELECTRONIC INDUSTRIES ASSOCIATION	WASHINGTON D.C.	20006
87034	MARCOAK INDUSTRIES	ANAHEIM, CALIF.	92803
91506	AUGAT INC.	ATTLEBORO, MASS.	02703
95354	METHODE MFG. CO.	ROLLING MEADOWS, ILL.	60008
96733	SAN FERNANDO ELECT. MFG. CO.	SAN FERNANDO, CALIF.	91341
98291	SEAELECTRO CORP.	MAMAPONECK, N.Y.	0544

Table 6-4.

PART NUMBER - NATIONAL STOCK NUMBER CROSS REFERENCE INDEX

PART NUMBER	FSCM	NATIONAL STOCK NUMBER	PART NUMBER	FSCM	NATIONAL STOCK NUMBER
A1H	87034	6240-00-951-3376	0698-3160	28480	5905-00-974-6078
B104BX102M	96733	5910-00-244-7171	0698-3399	28480	5905-00-405-2867
FDG1088	07263	5961-00-928-7939	0698-3437	28480	5905-00-402-7080
SR1358-4	04713	5961-00-496-7363	0698-3438	28480	5905-00-974-6080
0121-0414	28480	5910-00-402-1910	0698-3441	28480	5905-00-974-6076
0160-0155	28480	5910-00-719-4370	0698-3444	28480	5905-00-974-6079
0160-0300	28480	5910-00-058-7916	0698-3445	28480	5905-00-493-4289
0160-0345	28480	5910-00-803-4398	0698-3447	28480	5905-00-828-0404
0160-2055	28480	5910-00-211-1611	0698-3449	28480	5905-00-828-0397
0160-2152	28480	5910-00-410-9365	0698-3450	28480	5905-00-826-3262
0160-2199	28480	5910-00-244-7164	0698-3454	28480	5905-00-974-6077
0160-2208	28480	5910-00-430-5685	0698-7200	28480	5905-00-161-8936
0160-2266	28480	5910-00-430-5754	0698-7233	28480	5905-00-160-5437
0160-2327	28480	5910-00-244-7171	0757-0200	28480	5905-00-891-4224
0160-2357	28480	5910-00-451-3194	0757-0278	28480	5905-00-110-0851
0160-2437	28480	5910-00-431-3956	0757-0280	28480	5905-00-853-8190
0160-3456	28480	5910-01-014-2874	0757-0288	28480	5905-00-193-4318
0160-3460	28480	5910-00-008-4458	0757-0289	28480	5905-00-998-1908
0180-0049	28480	5910-00-781-9398	0757-0346	28480	5905-00-998-1906
0180-0116	28480	5910-00-809-4701	0757-0401	28480	5905-00-981-7529
0180-0228	28480	5910-00-719-9907	0757-0416	28480	5905-00-998-1795
0180-0374	28480	5910-00-931-7050	0757-0418	28480	5905-00-412-4037
0180-1746	28480	5910-00-430-6036	0757-0421	28480	5905-00-891-4219
0360-1514	28480	5940-00-150-4513	0757-0424	28480	5905-00-493-0736
0370-0133	28480	5355-00-917-1039	0757-0438	28480	5905-00-929-2529
0698-0082	28480	5905-00-974-6075	0757-0439	28480	5905-00-990-0303
0698-0083	28480	5905-00-407-0052	0757-0442	28480	5905-00-998-1792
0698-0084	28480	5905-00-974-6073	0757-0465	28480	5905-00-904-4412
0698-3151	28480	5905-00-246-8634	0757-0817	28480	5905-00-909-1778
0698-3154	28480	5905-00-891-4215	0757-1094	28480	5905-00-917-0580
0698-3155	28480	5905-00-976-3418	0811-1666	28480	5905-00-402-7082
0698-3156	28480	5905-00-974-6084	08554-00007	28480	5950-00-774-7261

Change 1 6-9

TABLE 6-4

PART NUMBER - NATIONAL STOCK NUMBER CROSS REFERENCE INDEX

PART NUMBER	FSCM	NATIONAL STOCK NUMBER	PART NUMBER	FSCM	NATIONAL STOCK NUMBER
08555-20093	28480	5999-00-008-8444	1902-3182	28480	5961-00-229-1966
0960-0084	28480	5985-00-787-2899	1902-3256	28480	5961-00-412-0957
1N4998	02735	5961-00-994-0520	2-330808-8	00779	5935-00-965-9612
1N5139	04713	5961-00-499-7905	2N2904A	80131	5961-00-913-5195
11593A	28480	5905-00-890-3393	2N3053	80131	5961-00-985-9073
1200-0041	28480	5935-00-971-9712	2N3055	80131	5961-00-985-9074
1200-0043	28480	5970-00-805-7166	2N3528	02735	5961-00-945-3380
1250-0118	28480	5935-00-897-9351	2N5179	80131	5961-00-401-0507
1250-0829	28480	5935-00-428-2944	2100-1758	28480	5905-00-228-5989
1250-0838	28480	5985-00-972-3149	2100-1760	28480	5905-00-229-1971
1250-0914	28480	5935-00-434-3040	2100-1775	28480	5905-00-228-5990
1251-0135	28480	5935-00-972-9464	2100-2522	28480	5905-00-476-5797
1251-0159	28480	5935-00-867-0119	2100-2728	28480	5905-00-161-9093
1251-1556	28480	5999-00-165-0403	2100-2730	28480	5905-00-532-2926
131-149	02660	5999-00-479-8176	2110-0012	28480	5920-00-898-0400
131-150	02660	5935-00-434-3040	2110-0201	28480	5920-00-280-9534
133-32-10-013	71785	5935-00-885-8598	2110-0269	28480	5999-00-333-9620
1400-0011	28480	5999-00-999-6875			
1490-0030	28480	6625-00-760-9521	2140-0244	28480	6240-00-951-3376
1820-0223	28480	5962-00-614-5251	251-15-30-261	71785	5935-00-867-0119
1853-0020	28480	5961-00-904-2540	3101-1248	28480	5930-00-476-9679
1854-0063	28480	5961-00-985-9074	3101-1395	28480	5930-00-164-0850
1854-0071	28480	5961-00-137-4608	50-045-4610	98291	5935-00-428-2944
1854-0221	28480	5961-00-836-1887	50-051-0109	98291	5935-00-858-8794
1854-0292	28480	5961-00-476-5731	50-085-0000	98291	5985-00-972-3149
1854-0345	28480	5961-00-401-0507	5000-0050	28480	6625-01-014-8071
1854-0404	28480	5961-00-408-9807	5040-0170	28480	6625-00-911-7214
1901-0040	28480	5961-00-965-5917	5040-0306	28480	5970-00-470-7622
1901-0159	28480	5961-00-496-7363	5060-0767	28480	6625-00-903-0348
1901-0200	28480	5961-00-994-0520	5060-1189	28480	6625-00-434-3251
1901-0633	28480	5961-00-408-9813	8120-1348	28480	6150-01-004-8773
1901-0639	28480	5961-00-787-3394			

TABLE 6-4

PART NUMBER - NATIONAL STOCK NUMBER CROSS REFERENCE INDEX

PART NUMBER	FSCM	NATIONAL STOCK NUMBER	PART NUMBER	FSCM	NATIONAL STOCK NUMBER
91-6915-1500-00	95354	5935-00-972-9464			
9100-2252	28480	5950-00-430-6904			
9100-2254	28480	5950-00-008-4471			

Change 1 6-11/(6-12 blank)

SECTION VII
MANUAL CHANGES

7-1. INTRODUCTION

Perform these changes in the sequence listed.

7-2. This section contains information for adapting this manual to instruments for which the content does not apply directly.

7-4. If your instrument serial number is not listed on the title page of this manual, or in Table 7-1 below, it may be documented in a yellow MANUAL CHANGES supplement. For additional important information about serial number coverage, refer to INSTRUMENTS COVERED BY MANUAL in Section I.

7-3. To adapt this manual to your instrument, refer to Table 7-1 and make all of the manual changes listed opposite your instrument serial number

Table 7-1. Manual Changes by Serial Number

Serial Prefix or No.	Make Manual Changes
1215A	A
1208A	A, B
1147A	A, B, C

7-5. MANUAL CHANGE INSTRUCTIONS

CHANGE A

Page 1-2, Table 1-1:

Change "Nonharmonic (Spurious) Signals" under Spectral Purity to >40 dB below output level.

Page 4-13, Paragraph 4-20:

Change "Nonharmonic (Spurious) Signals" in Specification to read:
>40 dB below output level.

Page 4-15, Paragraph 4-20, Step 12:

Change spurious to <--40 dBm.

Page 4-16, Table 4-1:

Change -35 to -40 for paragraph 4-20, Spurious Signal Level.

CHANGE B

Page 1-2, Table 1-1, change Spectral Purity: Harmonic Distortion specification to read:

Harmonic Distortion: 25 dB below output level.

Page 4-13, Paragraph 4-'20, Harmonic Distortion, change SPECIFICATION to read:

Harmonic Distortion: 25 dB below output level. Nonharmonic (spurious) signals: >40 dB below output level.

Page 4-15, Paragraph 4-20, change to read:

12. Note and record maximum amplitude level of harmonic and spurious signals.

Harmonics <--25 dBm
Spurious <--40 dBm

CHANGE C

Pages 5-3 through 5-6, Paragraph 5-9 and Figure 5-2, change to read as follows:

5-9. 1.55 GHz Oscillator Power Level, Frequency Check and Adjustment

REFERENCE: Service Sheet 3.

DESCRIPTION: The 1.55 GHz local oscillator is checked for power output level and frequency tuning range. Oscillator frequency is determined primarily by the LO cavity, with tuning range and power output level determined by the drive voltage from the oscillator driver. The oscillator is checked first for power level and then for frequency and tuning range. After any adjustments are made the previous checks are repeated.

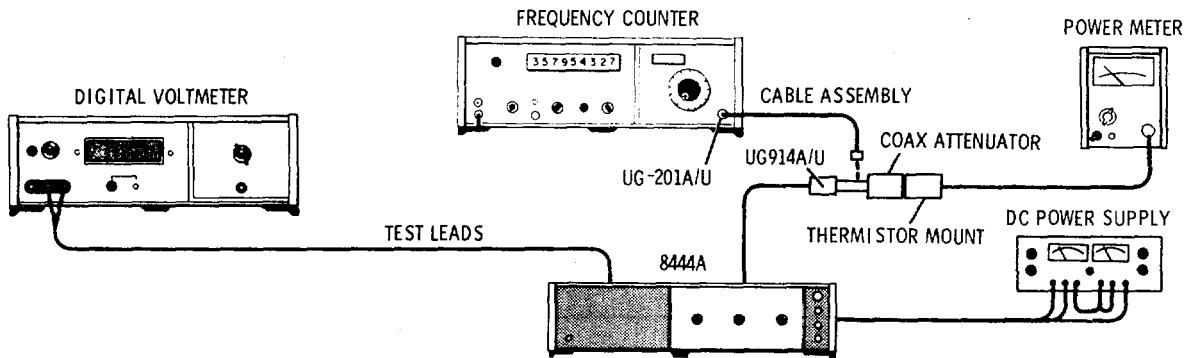

Figure 7-1. 1.55 GHz LO Power Level and Frequency Check and Adjustment Test Setup
(Manual Figure 5-2)

EQUIPMENT:

Power Meter with HP 8478B Thermistor Mount	HP 432A
Frequency Counter with HP 5254C Plug-in	HP 5245L
Digital Voltmeter with HP 3443A Plug-in	HP 3440A
Power Supply	HP 6205B
Test Leads (dual banana plug to probe and alligator clip)	HP 11003A
Cable Assy, SMA male to BNC male	HP 08555-60076
Cable Assy, male BNC connectors	HP 10503A
Coaxial Attenuator, Option 010	HP 8491A
Adapter BNC barrel (HP Part Number 1250-0080)	UG 914A/U
Adapter (BNC to Type N)	UG 201A/U

PROCEDURE:

1. Perform Power Supply Check and Adjustment, paragraph 5-8.
2. Apply power to Tracking Generator and allow 1 hour for instrument to warm up and stabilize.
3. Disconnect Cable W8 at Isolator AT3 J2 (see Figures 8-4 and 8-12).
4. With test setup as indicated in Figure 5-2, connect Power Meter to Isolator AT3 J2 via 08555-60076 cable, 10 dB attenuator and UG 914A/U adapter.
5. Rotate TRACK ADJ control throughout its tuning range while noting power level indicated on Power Meter.

5-9. 1.55 GHz Oscillator Power Level, Frequency Check and Adjustment (cont'd)

6. Record minimum power output. >+5 dBm
7. Connect Frequency Counter to Isolator AT3 J2 via 08555-60076 cable, UG 914A/1J adapter and BNC to BNC cable.
8. Rotate TRACK ADJ control fully counterclockwise and record oscillator frequency. 1,548,000±500 kHz
9. Rotate TRACK ADJ control fully clockwise and record oscillator frequency. 1,552,000±500 kHz
10. Record frequency tuning range (frequency recorded in step 9 minus frequency recorded in step 8). 4,000±500 kHz
11. If data recorded in steps 6, 8, 9, and 10 is within tolerance no adjustment is required.
12. If power level recorded in step 6 is less than +5 dBm proceed to step 23.
13. If data recorded in steps 8, 9, or 10 is not within tolerance proceed with step 14.
14. Connect Digital Voltmeter to test point A2TP5.
15. Set TRACK ADJ -control fully clockwise. Set "MAX" TUNE potentiometer A2R26 fully counterclockwise.
16. Adjust "MIN" TUNE potentiometer A2R27 to set voltage at test point A2I'P5 to level indicated on oscillator label. (See steps 23 through 30 for method of obtaining voltage level.)
17. Measure and record oscillator frequency.
18. Adjust "MAX" TUNE potentiometer to increase oscillator frequency 4, 000+50 kHz above frequency recorded in step 17. Record oscillator frequency.
19. Set TRACK ADJ control to center of tuning range recorded in steps 17 and 18 above. Record oscillator frequency.
20. If frequency recorded in step 19 is not within +500 kHz of 1.550 GHz adjust A7ADJ 1 to tune oscillator frequency to 1.550 GHz ±100 kHz.
21. If oscillator frequency is adjusted, repeat steps 15 through 20.
22. Repeat steps 4 through 11 above.
23. If power level recorded in step 6 is less than +5 dBm connect Power Meter as indicated in step 4. Remove right side panel cover. Unsolder and remove power wires from A7C2 and A7C3.
24. Adjust Power Supply for -10 and +10 volts. Connect -10 volts to A7C3 and +10 volts to A7C2. Connect Power Supply ground to solder lug near A7 Oscillator Assembly.

5-9. 1.55 GHz Oscillator Power Level, Frequency Check and Adjustment (cont'd)

25. Adjust Power Supply negative voltage for maximum oscillator power level as indicated on Power Meter. Record power level. >+7 dBm
26. If power level is less than +7 dBm replace Oscillator Assembly A7.
27. If power level is greater than +7 dBm reduce negative voltage from Power Supply to -10 volts.
 - a. If output level drops 2 dB go to step 30.
 - b. If output level drops less than 2 dB go to step 28.
 - c. If output level drops more than 2 dB go to step 29.
28. Increase Power Supply positive voltage approximately 0.5 volts and repeat steps 25 through 27.
29. Decrease Power Supply positive voltage approximately 0.5 volts and repeat steps 25 through 27.
30. Record positive voltage obtained in steps 24, 28 or 29 on label on top of oscillator assembly.
31. Repeat steps 14 through 22.
32. Disconnect Power Meter and connect W8 Cable to Isolator AT3 J2.
33. Replace right side panel cover.

Pages 6-3 through 6-5, Table 6-2, change to read as follows:

A2R29	0698-0465	R:FXD MET FLM 31.6 OHM 1% 1/8W.
A2R36	0757-0442	R: FXD MET FLM 10K OHM 1% 1/8W.
A4A1C2	0160-2266	C:FXD CER 24PF 5% 500 VDCW, 72982, 301-000-COGO-240J
A7	08444-60003	OSCILLATOR ASSY: 1.55 GHz NOT RECOMMENDED FOR FIELD REPAIR.
A7	C10160-3549	C:FXD PORC 0.5-0.1 PF 500 VDCW, 28480, 0160-3549.
Delete A7C4		
A7	R10698-7205	R:FXD MET FLM 51.1 OHM 2% 1/8W.
Delete C3		
Delete R5		

Page 8-15, Figure 8-12, Service Sheet 3:

Replace with Figure 7-2.

Page 8-21, Figure 8-19:

Replace with Figure 7-3.

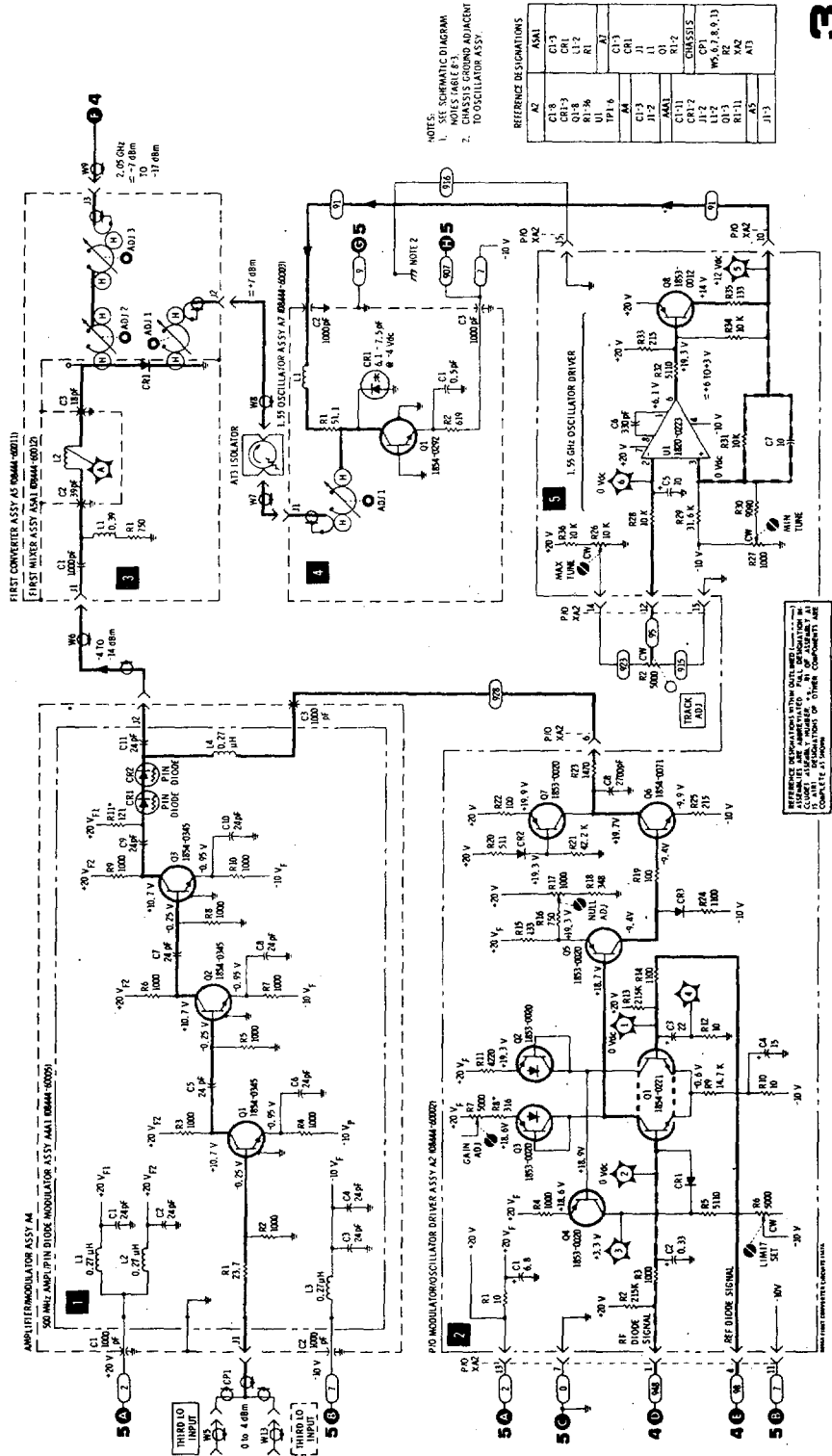

Figure 7-2. First Converter Circuits, Schematic Diagram, Manual Figure 8-12 (CHANGE C)

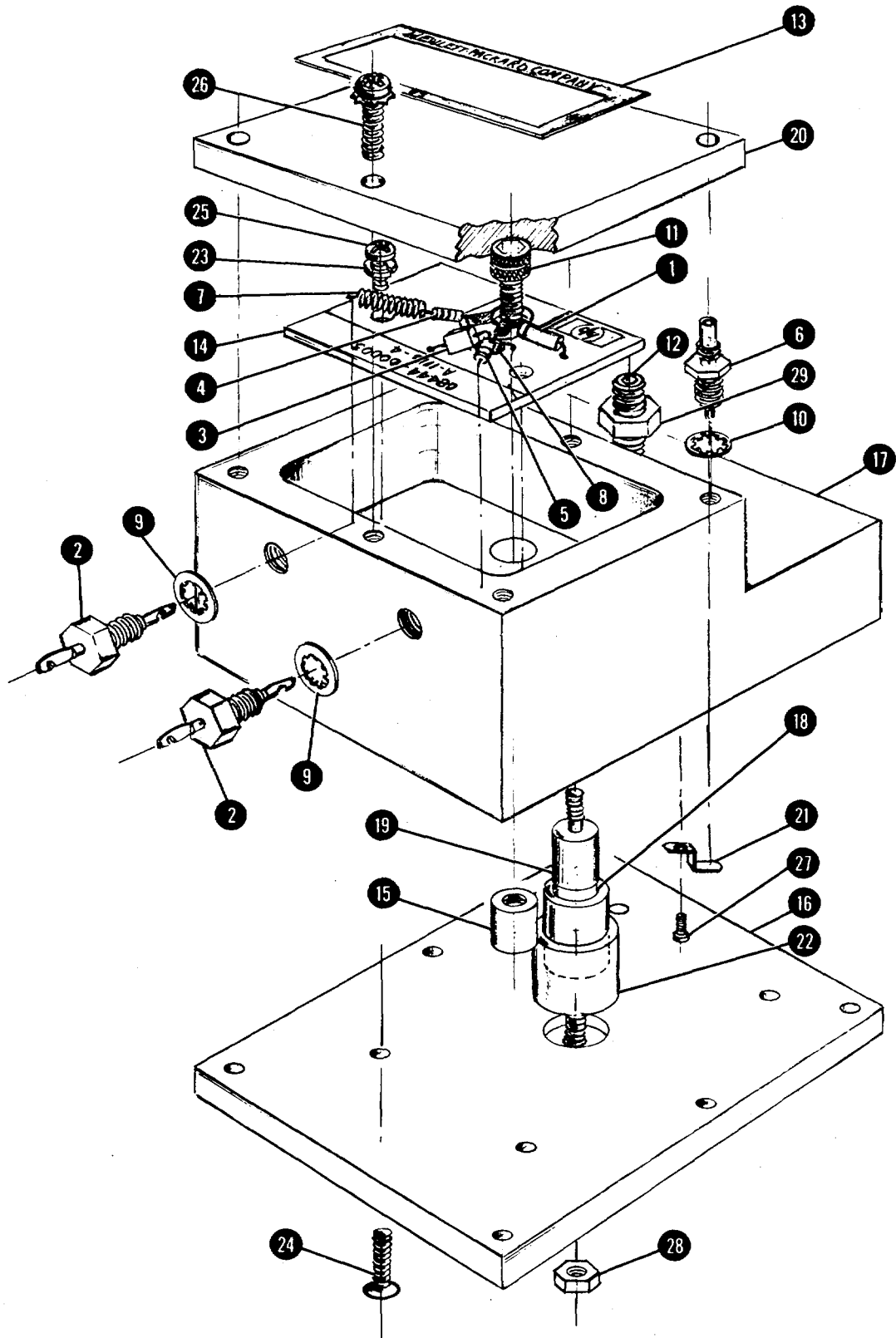

Figure 7-3. A 7 1.55 GHz Oscillator Assembly, Illustrated Parts Breakdown, Manual Figure 8-19 (1 of 2) (for Change C)

7-6. MANUAL CHANGE SUPPLEMENT

This supplement contains important information for adapting the manual to instruments containing improvements made after the printing of the manual.

To use this supplement:

Make all appropriate serial number related changes indicated in the tables below.

Serial Prefix or Number	Make Manual Changes	Serial Prefix or Number	Make Manual Changes
1601A, 1630A	1		

CHANGE 1

Page 6-6, Table 6-2:
Change A8 HP Part Number to 0960-0444.

Page 6-7, Table 6-2:
Change SI HP Part Number to 3101-1395.

Page 8-19, Figure 8-17, Service Sheet 5:
Replace ON/OFF switch S1 and POWER LINE MODULE A8, wiring diagram and schematic, with Figure 1 of this MANUAL CHANGES.

SECTION VIII**SERVICE****8-1. INTRODUCTION**

8-2. This section provides instructions for troubleshooting and repair of the HP Model 8444A Tracking Generator.

8-3. PRINCIPLES OF OPERATION

8-4. Information relative to the principles of operation appears on the foldout pages opposing the Block Diagram, Service Sheet 1. Theory of operation appears on the foldout pages facing each of the foldout schematic diagrams. The schematic diagram circuits are referenced in the theory of operation test by block numbers.

8-5. RECOMMENDED TEST EQUIPMENT

8-6. Test equipment and accessories required to maintain the Tracking Generator are listed in Table 1-3. If the equipment listed is not available, equipment that meets the required specifications may be substituted.

8-7. TROUBLESHOOTING

8-8. Troubleshooting procedures are divided into two maintenance levels in this manual. The first, a troubleshooting tree, is designed to isolate the malfunction to the defective circuit.

8-9. The second maintenance level provides circuit analysis and test procedures to aid in isolating faults to a defective component. Circuit descriptions and test procedures for the second maintenance level are located on the pages facing the schematic diagrams. The test procedures are referenced to the schematic diagrams by block numbers.

8-10. After the cause of a malfunction has been found and remedied in any circuit containing adjustable components, the applicable procedure specified in Section V of this manual should be performed. After repairs and/or adjustments have been made, the applicable procedure specified in Section IV of this manual should be performed.

8-11. REPAIR

8-12. Factory Repaired Exchange Modules. The LSI microcircuit, Amplifier and ALC Detector Assy A3, is available as a factory repaired exchange module. The factory repaired module is available at a considerable savings in cost over the new module.

8-13 This exchange module should be ordered from the nearest Hewlett-Packard Sales and Service office using the part number in the replaceable parts table in Section VI of this manual. Virtually all orders for replacement parts received by HP offices are shipped the same day received --either from the local office or from a Service Center.

8-14. Factory Selected Components. Some component values are selected at the time of final checkout at the factory. Usually these values are not extremely critical; they are selected to provide optimum compatibility with associated components. These components, which are identified on the schematics with an asterisk, are listed in Table 84. The recommended procedure for replacing a factory-selected component is as follows:

a. Try the original value, then perform the test specified in Section V of this manual for the circuit being repaired.

b. If the specified test cannot be satisfactorily performed, try the typical value shown in the parts list and repeat the test.

c. If the test results are still not satisfactory, substitute various values until the desired result is obtained.

8-15. Adjustable Components. Adjustable components, other than front panel operating controls, are listed in Table 8-2 Adjustment procedures for these components are contained in Section V of this manual.

8-16. Servicing Aids on Printed Circuit Boards. Servicing aids on printed circuit boards include test points, transistor designations, adjustment callouts and assembly part numbers with alpha-numerical revision information.

8-17. Part Location Aids. The location of chassis mounted parts and major assemblies are shown in Figures 8-4 and 8-5.

8-18. The location of individual components mounted on printed circuit boards or assemblies are shown on the appropriate Service Sheet. The part reference designator is the assembly designation plus the part designation. (Example: A1RI is R1 on the AI assembly.) For specific component description and ordering information refer to the replaceable parts table in Section VI.

Table 8- 1. Factory Selected Components

Designation	Service Sheet	Circuit	Purpose
A2R8	3	ALC Differential Amplifier	Center GAIN ADJ control
A4AIR11	3	PIN Diode Modulator	Set range of Modulator

Table 8-2. Adjustable Components

Designation	Circuit	Purpose
R1	+20 volt circuit	MANUAL SCAN control
R2	Oscillator driver	TRACK ADJ control
R3	ALC reference driver	LEVEL control
AIR14	+20 volt power supply	Sets +20 volt supply level and reference level to -10 volt supply.
A2R6	PIN diode driver	Sets limiting level of PIN diode driver
A2R7	PIN diode driver	Sets gain of differential amplifier in PIN diode driver circuit.
A2R17	PIN diode driver	Sets PIN diode driver circuit for null.
A2R26	1.55 GHz oscillator driver	Set frequency tuning range of 1.55 GHz oscillator.
A2R27	1.55 GHz oscillator driver	Sets oscillator power level.
A2R40	ALC reference diode circuit	-10 dBm adjustment for LEVEL control.
A2R41	ALC reference diode circuit	0 dBm adjustment for LEVEL control.
A5ADJ 1	First converter	Adjusts center frequency of 1.55 GHz cavity.
A5ADJ 2/3	First converter	Adjusts center frequency of 2.05 GHz cavities.
A7 ADJ 1	1.55 oscillator	Adjusts center frequency of 1.55 GHz oscillator cavity.

8-19. **Diagram Notes.** Table 8-3, Schematic Diagram Notes, provides information relative to symbols and values shown on schematic diagrams.















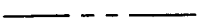



8-20. GENERAL SERVICE HINTS

8-21. The etched circuit boards used in Hewlett Packard equipment are the plated-through type consisting of metallic conductors bonded to both sides of an insulating material. The circuit boards can be either a single layer or multi-layer board. The metallic conductors are extended through the component holes or interconnect holes by a plating process. Soldering can be performed on either side of the board with equally good results. Table 8-4 lists recommended tools and materials for use in

repairing etched circuit boards. Following are recommendations and precautions pertinent to etched circuit repair work.

- a. Avoid unnecessary component substitution; it can result in damage to the circuit board and/or adjacent components.
- b. Do not use a high power soldering iron on etched circuit boards. Excessive heat may lift a conductor or damage the board.
- c. Use a suction device or wooden toothpick to remove solder from component mounting holes.

Table 8-3. Schematic Diagram Notes

SCHEMATIC DIAGRAM NOTES	
Refer to USAS Y32.2-1967	
R,C,L	Resistance is in ohms, capacitance is in microfarads, and inductance in millihenries unless otherwise noted.
P/O	Part of.
*	Asterisk denotes a factory-selected value. Value shown is typical. Capacitors may be omitted or resistors jumpered.
	Screwdriver adjustment.
	Panel control.
	Encloses front panel designations.
	Encloses rear panel designations.
	Circuit assembly borderline.
	Other assembly borderline.
	Heavy line with arrows indicates path and direction of main signal.
	Heavy dashed line with arrows indicates path and direction of main feedback.
	Wiper moves toward CW with clockwise rotation of control (as viewed from shaft or knob).
	Numbered test point. Measurement aid provided.
	Lettered test point. No measurement aid provided.
	Encloses wire color code. Code used (MIL-STD-681) is the same as the resistor color code. First number identifies the base color, second number the wider stripe, and the third number identifies the narrower stripe, e.g., denotes white base, yellow wide stripe, violet narrow stripe.
	Indicates "WARNING: HAZARDOUS VOLTAGE."
	Refers serviceman or operator to CAUTIONs in Operating and Service Manual.
	Letter = Off page connection. Number = Service Sheet location for off page connection.
	Block numbers reference between text and schematic.
	Assembly ground.
	Chassis ground.

CAUTION

Do not use a sharp object such as an awl or twist drill for this purpose. Sharp objects may damage the plated-through conductor.

d. After soldering, remove excess flux from the soldered areas and apply a protective coating to prevent contamination and corrosion.

8-22. Component Replacement. The following procedures are recommended when component replacement is necessary:

- a. Remove defective component from board.
- b. If component was unsoldered, remove solder from mounting holes with a suction device or a wooden toothpick.
- c. Shape leads of replacement component to match mounting hole spacing.
- d. Insert component leads into mounting holes and position component as original was positioned. Do not force leads into mounting holes: sharp lead ends may damage the plated through conductor.

NOTE

Although not recommended when both sides of the circuit board are accessible, axial lead components such as resistors and tubular capacitors, can be replaced without unsoldering. Clip leads near body of defective component, remove component and straighten leads left in board. Wrap leads of replacement component one turn around original leads. Solder wrapped connection and clip off excess lead.

8-23. GENERAL SERVICE INFORMATION

8-24. Transistors and diodes are used throughout the RF Section in circuit configurations such as delay circuits, trigger circuits, switches, oscillators and various types of amplifiers. Basic transistor operation is shown on the following pages.

8-25. Transistor In-Circuit Testing. The common causes of transistor failure are internal short circuits and open circuits. In transistor circuit testing, the most important consideration is the transistor base-to-emitter junction. The base emitter junction in a transistor is comparable to the control grid-cathode

Table 8-4. Etched Circuit Soldering Equipment

Item	Use	Specification	Item Recommended
Soldering tool	Soldering Unsoldering	Wattage rating: 47½ – 56½ Tip Temp: 850–900 degrees	Ungar No. 776 handle with *Ungar No. 4037 Heating Unit
Soldering* Tip	Soldering Unsoldering	*Shape: pointed	*Ungar No. PL111
De-soldering Aid	To remove molten solder from connection	Suction device	Soldapult by Edsyn Co., Arleta, California
Resin (flux)	Remove excess flux from soldered area before application of protective coating.	Must not dissolve etched circuit base board material or conductor bonding agent.	Freon, Aceton, Lacquer Thinner, Isopropyl Alcohol (100% dry)
Solder	Component replacement Circuit board repair Wiring	Resin (flux) core, high tin content (60/40 tin/lead). 18 gauge (SWG) preferred.	
Protective Coating	Contamination, corrosion protection.	Good electrical insulation, corrosion-prevention properties.	Krylon **No. 1302 Humiseal Protective Coating, Type 1B12 by Columbia Technical Corporation, Woodside 77, New York

*For working on etched boards: for general purpose work, use Ungar No. 1237 Heating Unit (37.5W, tip temperature of 750–800 degrees) and Ungar No. PL113, 1/8 inch chisel tip.

**Krylon, Inc., Norristown, Pennsylvania.

Model 8444A

cathode relationship in a vacuum tube. The base emitter junction is essentially a solid-state diode; for the transistor to conduct, this diode must be forward biased. As with simple diodes, the forward-bias polarity is determined by the materials forming the junction. Transistor symbols on schematic diagrams reveal the bias polarity required to forward-bias the base-emitter junction. The B part of Figure shows transistor symbols with the terminals labeled. The other two columns compare the biasing required to cause conduction and cutoff in NPN and PNP transistors. If the transistor base-emitter junction is forward biased, the transistor conducts. However, if the base-emitter junction is reverse-biased, the transistor is cut off (open). The voltage drop across a forward-biased, emitter base junction varies with transistor collector current. For example, a germanium transistor has a typical forward-bias, base-emitter voltage of 0.2-0.3 volt when collector current is 1-10 mA, and 0.4-0.5 volt when collector current is 10-100 mA. In contrast, forward-bias voltage for silicon transistor is about twice that for germanium types; about 0.5-0.6 volt when collector current is low, and about 0.8-0.9 volt when collector current is high.

8-26. Figure 8-1, Part A, shows simplified versions of the three basic transistor circuits and gives the characteristics of each. When examining a transistor stage, first determine if the emitter-base junction is biased for conduction (forward-biased) by measuring the voltage difference between emitter and base. When using an electronic voltmeter, do

not measure directly between emitter and base; there may be sufficient loop current between the voltmeter leads to damage the transistor. Instead, measure each voltage separately with respect to a common point (e.g., chassis). If the emitter-base junction is forward-biased, check for amplifier action by short-circuiting base to emitter while observing collector voltage. The short circuit eliminates base-emitter bias and should cause the transistor to stop conducting (cut off). Collector voltage should then change and approach the supply voltage. Any difference is due to leakage current through the transistor and, in general, the smaller this current the better the transistor. If the collector voltage does not change, the transistor has either an emitter-collector short circuit or emitter base open circuit.

8-27. Transistor and Diode Markings. Figure 8-2 illustrates examples of diode and transistor marking methods. In addition, the emitter lead for bipolar transistors is identified on the printed circuit boards.

8-28. OPERATIONAL AMPLIFIERS

8-29 Operational amplifiers are used to provide such functions as summing amplifiers, offset amplifiers, buffers and power supplies. The particular function is determined by the external circuit connections. Equivalent circuit and logic diagrams for type 741 operational amplifiers are contained in Figure 8-3, Circuit A is a non-inverting buffer amplifier with a gain of 1. Circuit B is a non

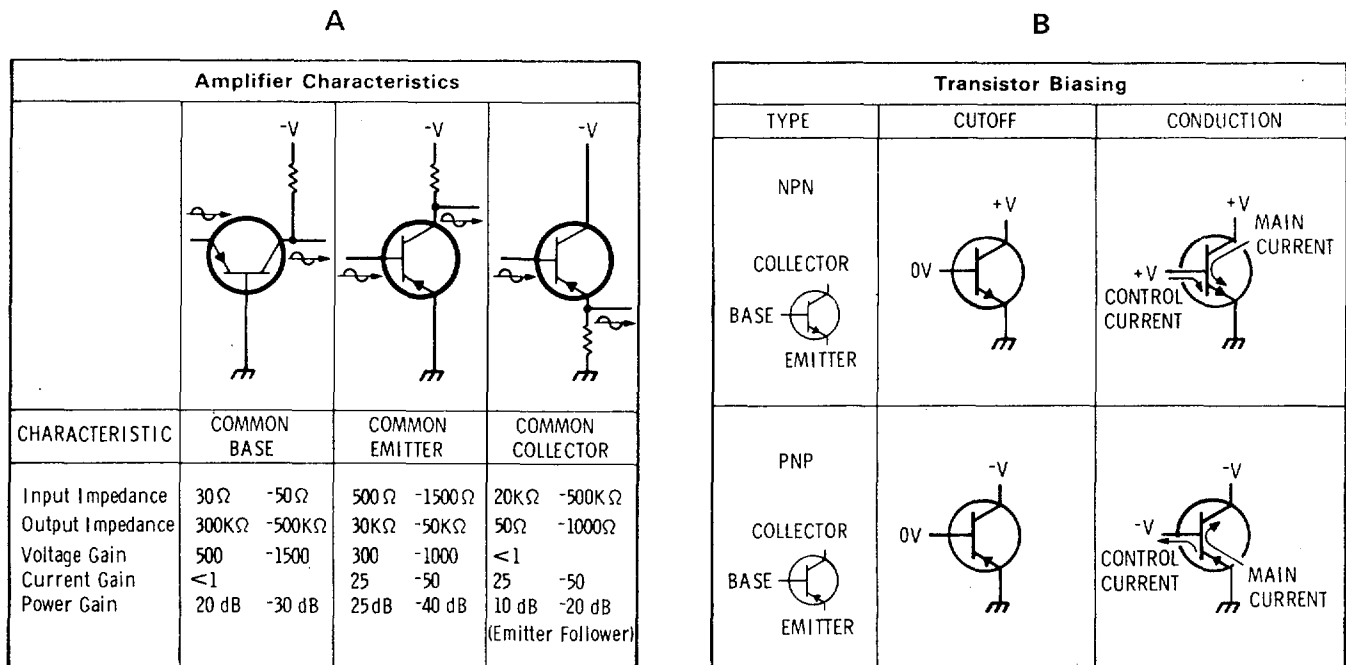

Figure 8-1. Transistor Operation
8-5

inverting amplifier with gain determined by the resistance of R1 and R2. Circuit C is an inverting amplifier with gain determined by R1 and R2, with the input impedance determined by R2. Circuit D contains the functional circuitry and pin connection information along with an operational amplifier review.

Note

In Circuit D it is assumed that the amplifier has high gain, low output impedance and high input impedance.

8-30. Operational Amplifier Troubleshooting Procedure. Measure and record the voltage level at both the (inverting) terminal pin 2 and the + (noninverting) terminal pin 3. The level should not differ by more than m 10 mV. If the voltage level is not within m 10 mV, check the external circuitry and components. If the external circuitry (input signal, operating voltages, feedback resistors) is normal, replace the operational amplifier.

8-31. ELECTRICAL MAINTENANCE

8-32. Perform the electrical checks and adjustments once every six months and after repair or component replacement.

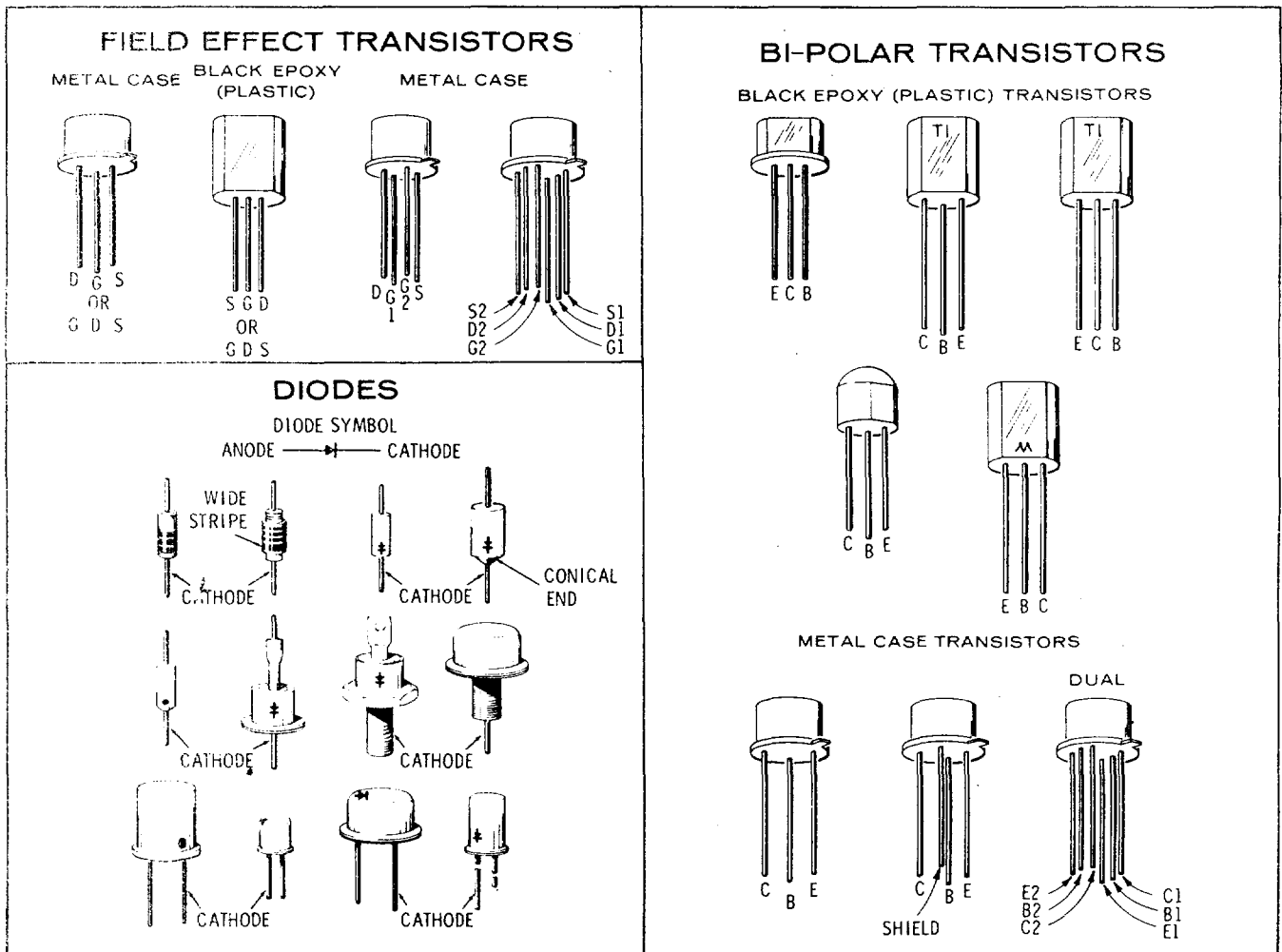

Figure 8-2. Examples of Diode and Transistor Marking Methods

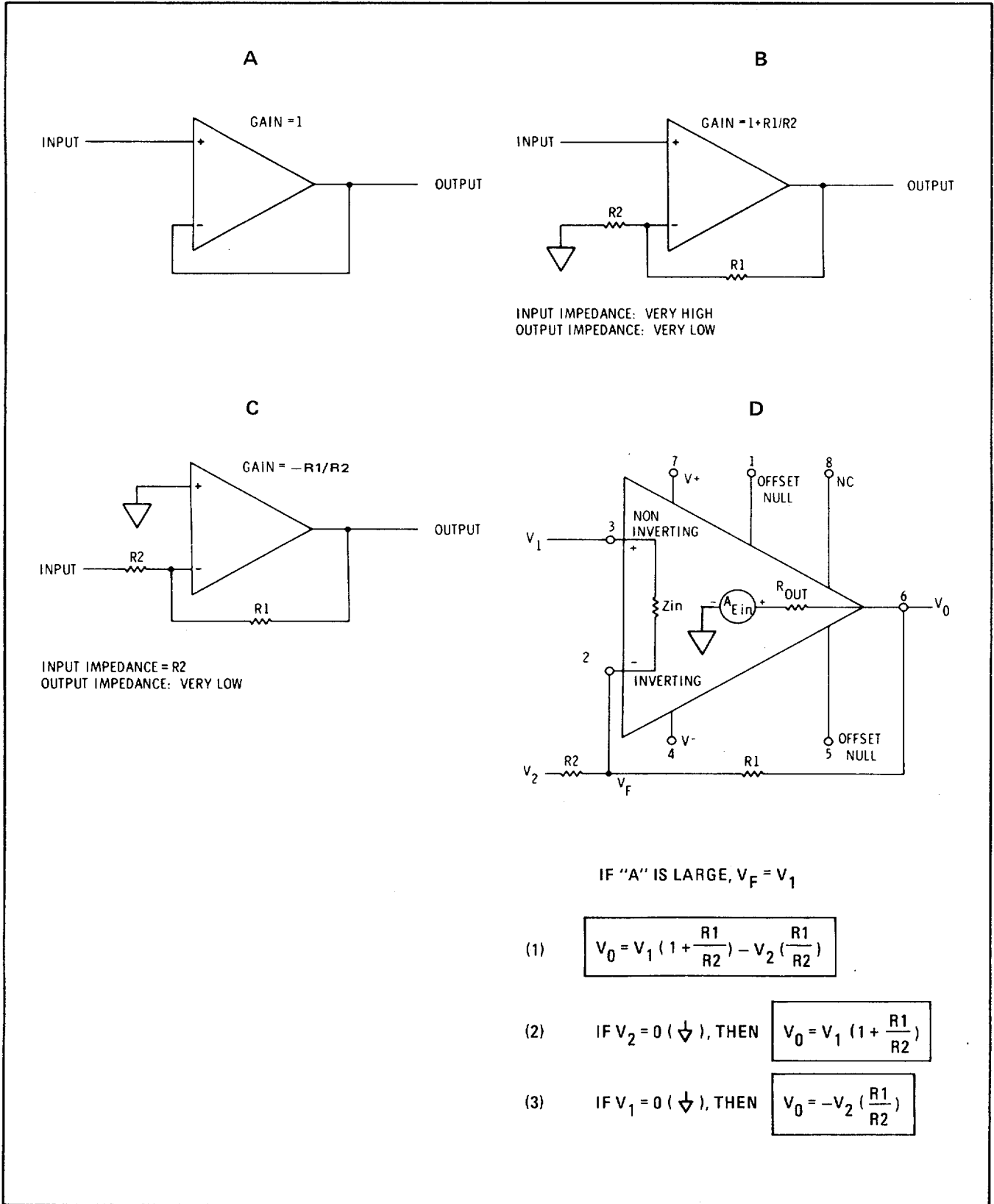

Figure 8-3. Operational Amplifier Equivalent Circuit
8-7/8-8

Model 8444A

TM 11-6625-2866-14&P

Service

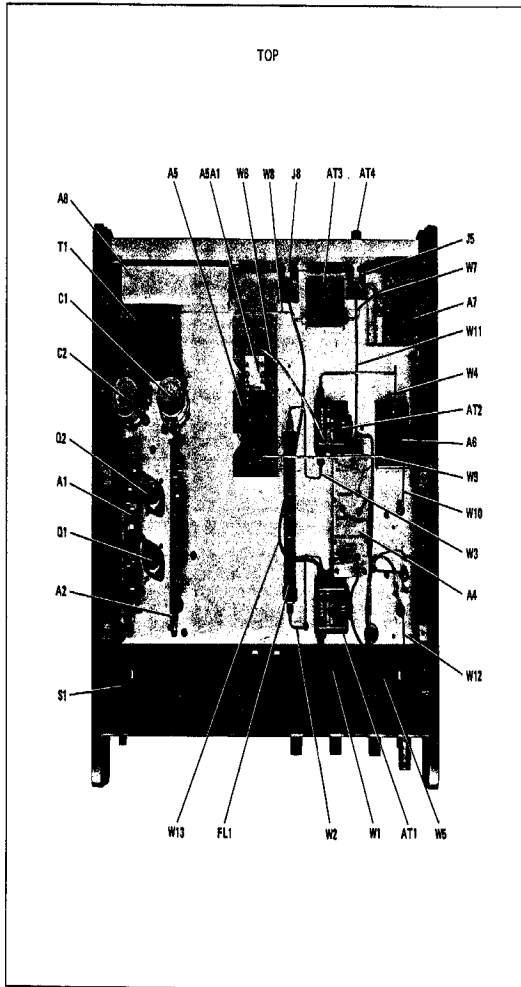

Figure 8-4. Major Assembly Locations (1)

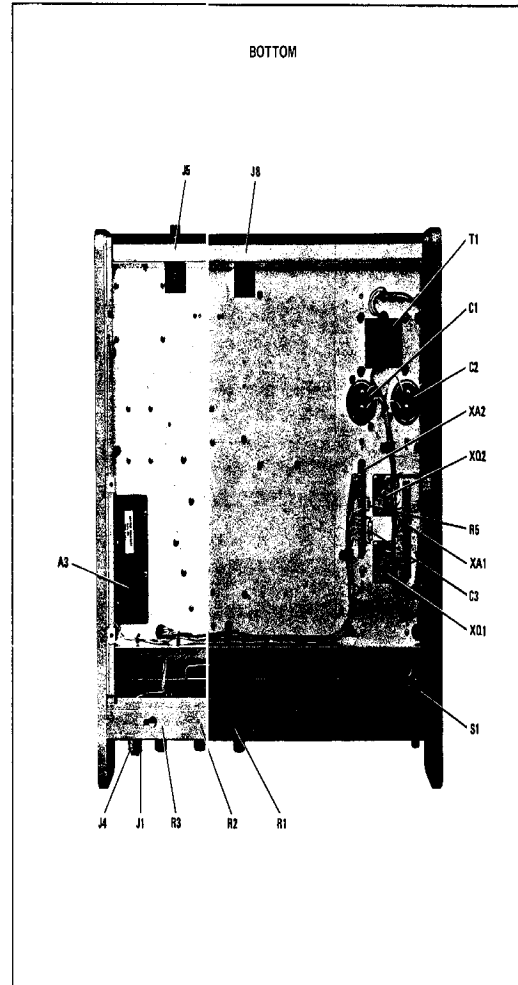

Figure 8-4. Major Assembly Locations

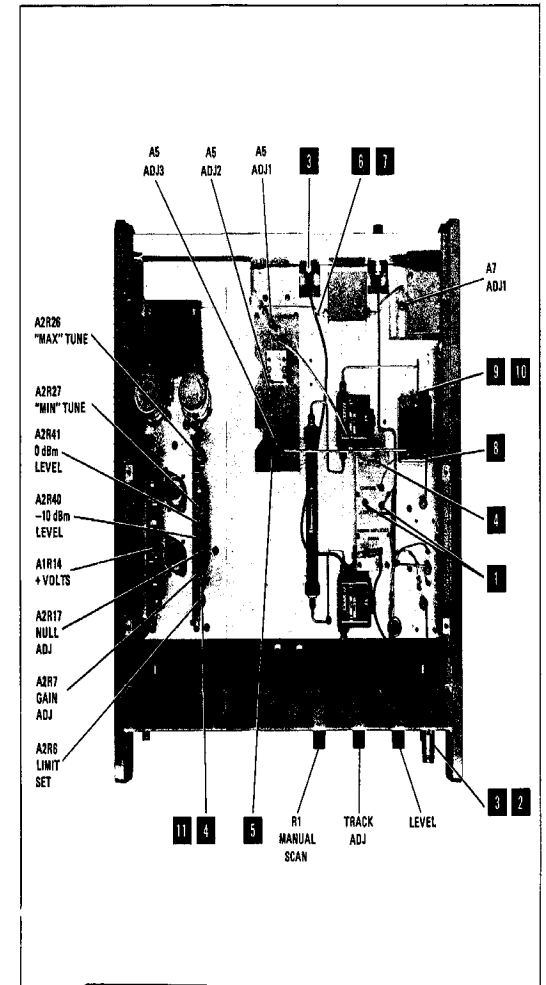

Figure 8-5. Adjustment and Test Point

8-9

SERVICE SHEET 1

GENERAL

The HP Model 8444A Tracking Generator is designed for operation with either the HP Model 8554L/8552L/1140-series or the HP Model 8555A/8552L/1140-series Spectrum Analyzer Systems. When used with the 8554L Spectrum Analyzer RF Section, the Tracking Generator covers the full range of the analyzer system. When used with the 8555A Spectrum Analyzer RF Section, the Tracking Generator covers the 10 MHz to 1.3 GHz frequency range on the n=1 (2.05 GHz IF) band.

A simplified block diagram of the Spectrum Analyzer/tracking generator system is illustrated in Figure 7-6. In the spectrum analyzer/tracking generator system, the tracking generator provides a signal that tracks the frequency tuning of the spectrum analyzer. The first and third local oscillators in the spectrum analyzer are applied to the tracking generator where they are combined with the output of a 1.55 GHz cavity oscillator. The frequency of the cavity oscillator corresponds with the 1.5 GHz second local oscillator, the 47 MHz fourth local oscillator and the 3 MHz IF signal to the detector in the spectrum analyzer. The 1.55 GHz cavity oscillator is voltage-tunable by the front panel TRACK ADJ control, to compensate for minor frequency variations of the second and fourth local oscillators in the spectrum analyzer.

The power level of the tracking generator rf output is controlled by an ALC circuit. The ALC detector is part of a large-scale integrated (LSI) circuit package containing an attenuator, low-pass filter, output amplifier and a dc blocking capacitor. The detected signal is applied through a dc amplifier to PIN diode modulators in the third LO signal path to the tracking generator first converter. The rf output level is adjustable over the 0 to -10 dBm range by a front panel LEVEL control in the dc amplifier circuit. The LEVEL control is calibrated at 0 dBm.

Figure 7-7 contains a block diagram of the tracking generator with interconnections to both the 8554L and 8555A Spectrum Analyzer Systems. The first LO inputs is applied through isolators and a 2.0 to 3.4 GHz bandpass filter to the second converter. The third LO input is applied through a 500 MHz limiter amplifier and PIN diode modulators to the second converter. The 500 MHz third LO signal is combined with the output from the 1.55 GHz cavity oscillator. The output from the first converter has a center frequency of 2.05 GHz with a tuning range of ±2 MHz plus the deviation of the 500 MHz signal from the analyzer. The 2.05 GHz first converter output is mixed with the 2.05 to 3.4 GHz output from the bandpass filter in the second converter. The second converter output is applied through the 0 to 1.3 GHz low-pass filter, amplifier and ALC circuitry. The resultant output is a signal in the frequency range of 0 to 1.3 GHz at a level of 0 to -10 dBm.

Sweep and tune control of the Spectrum Analyzer from the Tracking Generator is provided by a 0 to +10 volt signal controlled by a front panel MANUAL SCAN control.

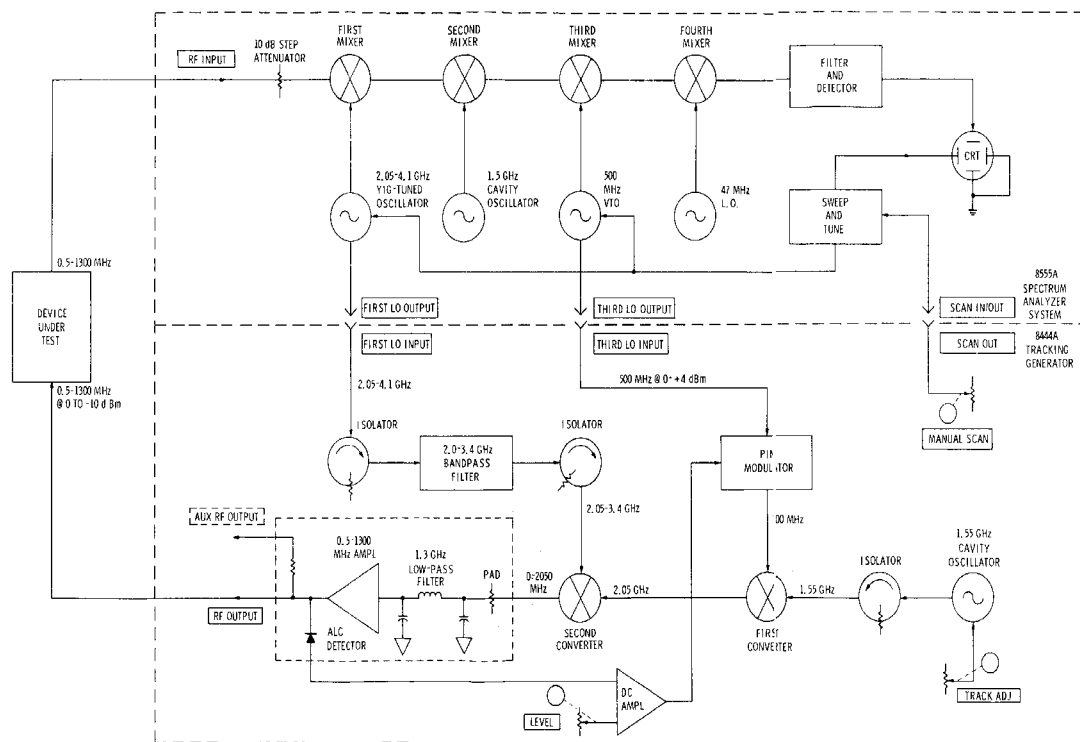

Tracking Generator Views
 Adjustment and Test Point Locations

Figure 8-6. Tracking Generator Spectrum Analyzer, Simplified Block Diagram

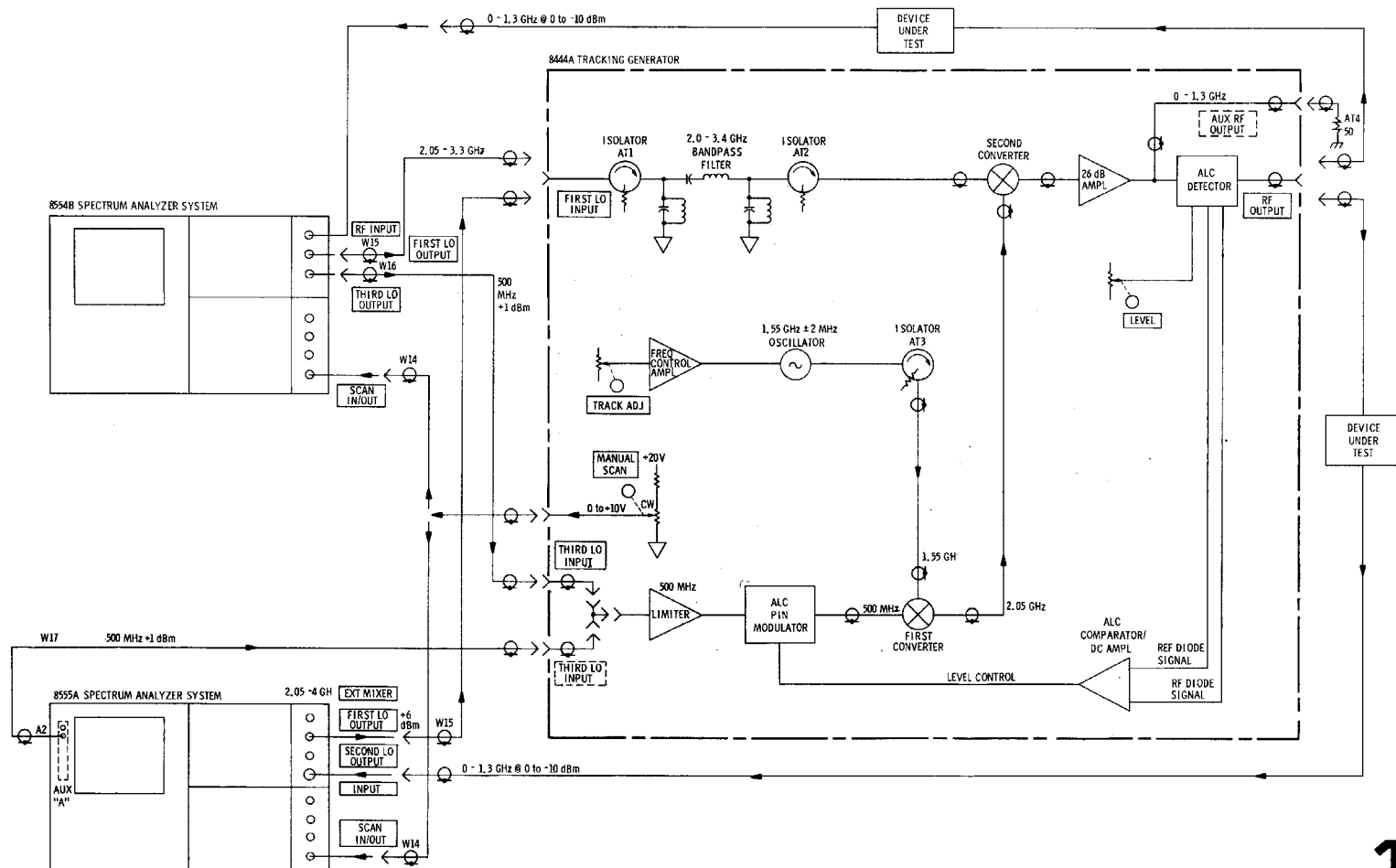

Figure 8-7. Tracking Generator, Block diagram with Spectrum Analyzer Interconnections

TRACKING GENERATOR TROUBLESHOOTING TREE

INTRODUCTION

The troubleshooting tree is designed to isolate a malfunction to the component or assembly level. During troubleshooting the ALC loop is disabled and adjusted to a power level equivalent to the normal loop level.

Prior to troubleshooting the Tracking Generator, ensure that the Spectrum Analyzer is functioning properly and all interconnections are correct.

Block reference numbers in the troubleshooting tree correspond with block numbers on the block diagram and with the test points on the test point illustration.

Perform the procedure in the order given with the test equipment listed or with test equipment meeting the minimum specifications listed in Table 1-3.

TEST EQUIPMENT:

Digital Voltmeter	HP 3440A/3443A
Frequency Counter	HP 5245L/5254B
Power Meter	HP 432A/8478B
Coaxial Attenuator	HP 8491A Option 10
Spectrum Analyzer System	HP 8554B or 8555A/8552()/140-series
Low-Pass Filter	HP 360A
BNC Cable	HP 10505A
Adapter BNC-Jack to BNC-Jack	UG-914A/C (HP 1250-0080)
Test lead with alligator clips	common
Wrench 5/16-inch open end	HP 8720-0030
Wrench 15/64-inch open end	HP 8710-0946

PROCEDURE:

It is assumed that the Tracking Generator/Spectrum Analyzer did not perform as called out in the Preset Adjustment Procedure in Paragraph 4-7 or 4-9.

Set Tracking Generator controls as follows:

LINE	ON
MANUAL SCAN	Max CCW
TRACK ADJ	Centered
LEVEL	-0 dBm

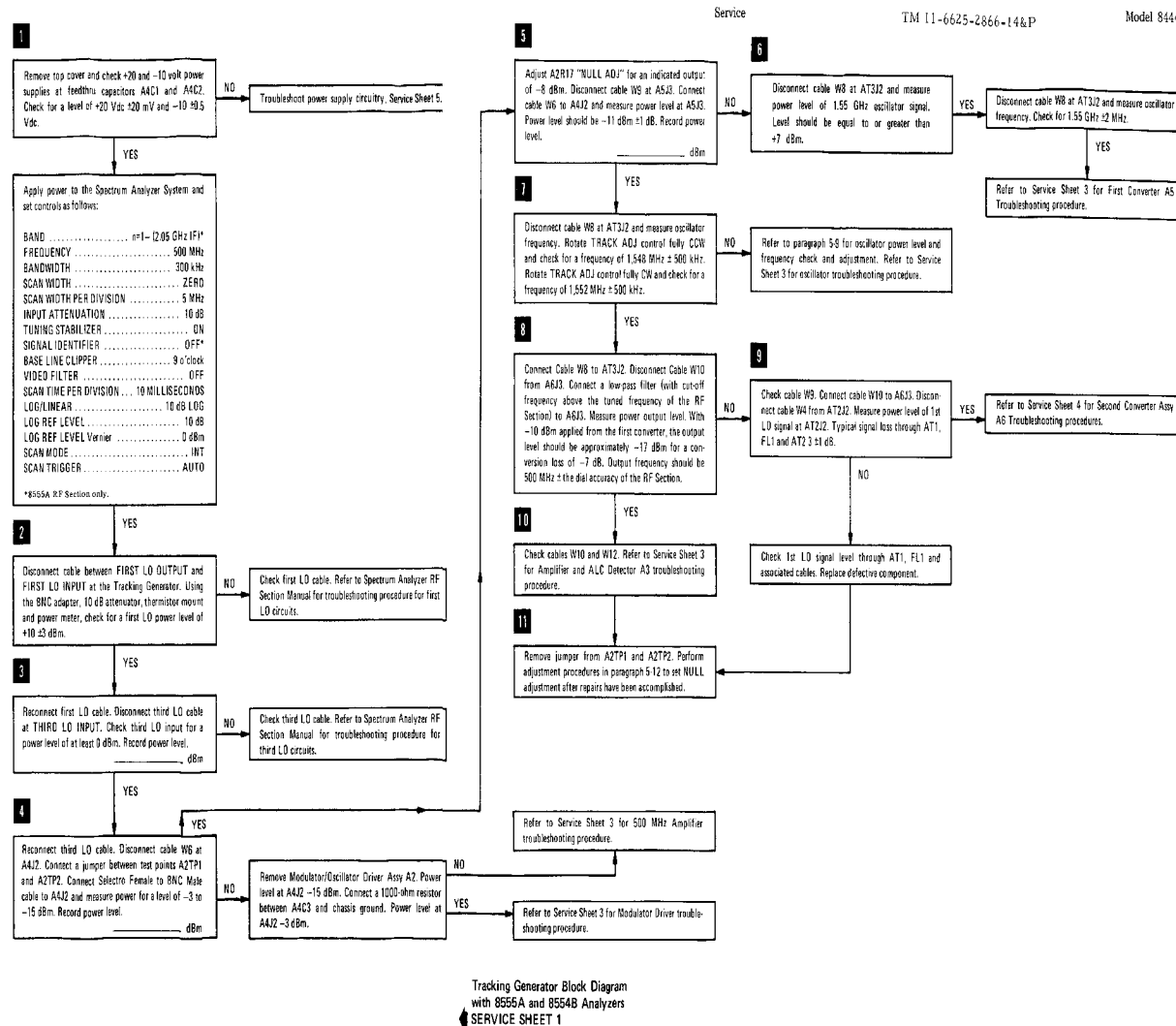

Figure 8-7A. Troubleshooting Tree

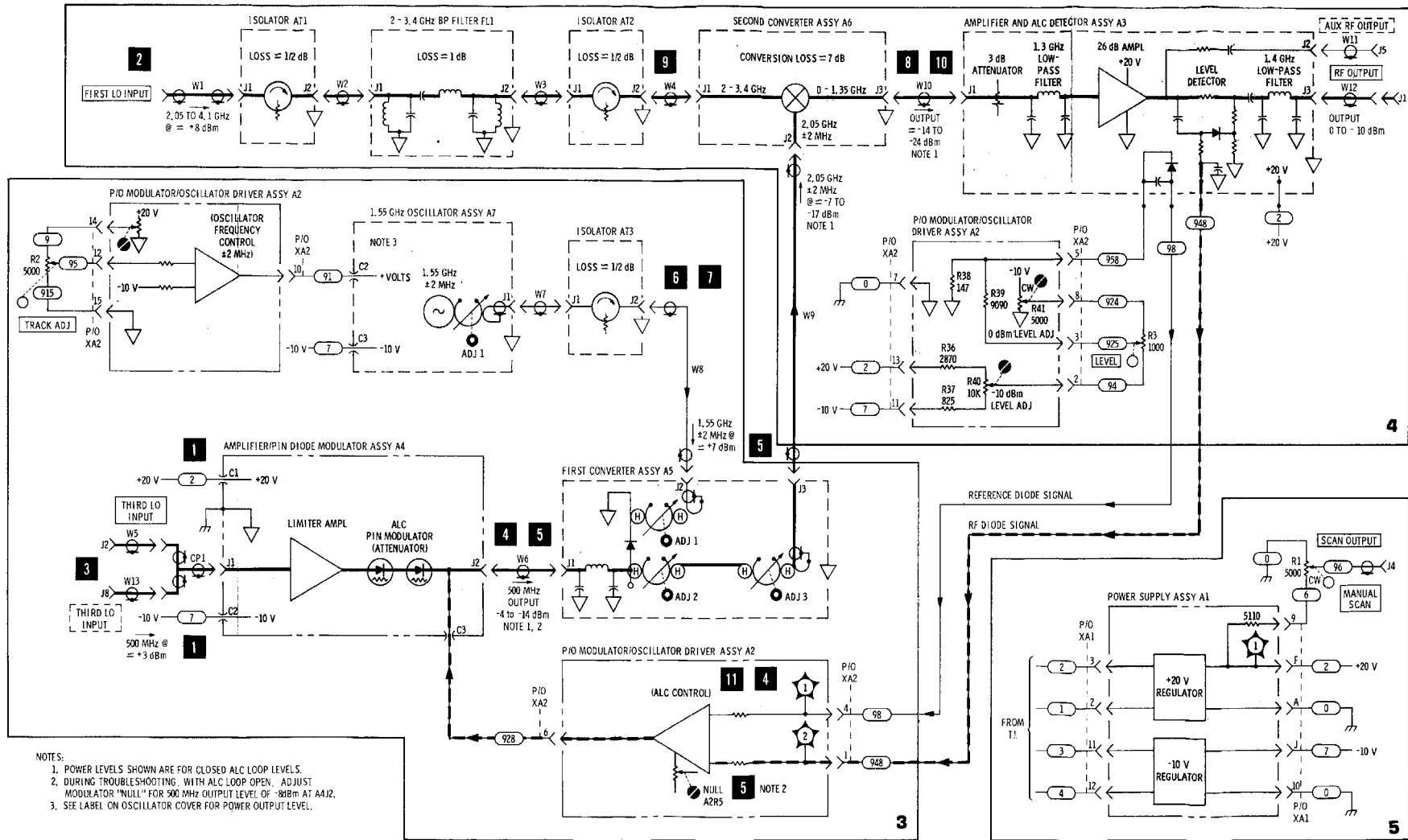

Figure 8-8. Tracking Generator Troubleshooting Block Diagram

ERVICE SHEET 3

HEORY OF OPERATION

ervice Sheet 3 contains the schematic diagram for the 500 MHz mplifier/PIN Diode Modulator (Attenuator) A4, the Modulator/Oscillator iver A2, First Converter A5 and the 1.55 GHz Oscillator A7.

500 MHz AMPLIFIER/PIN DIODE MODULATOR (ATTENUATOR) A4

he 500 MHz amplifier and PIN diode modulator consists of amplifier A41Q1 through Q3 and PIN diodes A4CR1 and CR2. The three stage mplifier provides isolation between the Tracking Generator attenuator and iver circuits and the Spectrum Analyzer 500 MHz LO circuit. The mplifier functions as a limiter in the forward direction of the 500 MHz gnal while providing approximately 55 dB attenuation in the reverse irection. This isolation prevents signals from the first mixer and changes in e 500 MHz signal by the PIN diode attenuator from affecting the 500 MHz scillator in the Spectrum Analyzer. PIN diodes A4CR1 and CR2 function as ices connected current-controlled microwave resistors. As current through e PIN diodes increases the amount of attenuation decreases. Current through e PIN diodes is controlled by ALC circuitry and the output of Modulator iver Assy A2. A4A1R1 is a limiter resistor to protect the PIN diodes in ase of an accidental short to the line from the modulator driver.

MODULATOR DRIVER

he modulator driver consists of differential amplifier A2Q1 through Q3, iver A2Q4 and output amplifier A2Q5 through Q7. The difference etween the rf diode and the reference diode signal (from the ALC circuitry e microcircuit amplifier) is amplified by A2Q1. The output of A2Q1 is mplified by the output amplifier A2Q5 through Q7 to control the current o the PIN diode modulators.

FIRST CONVERTER A5

he first converter mixes the signal from the 500 MHz Amplifier/PIN Diode odulator with the signal from the 1.55 GHz Oscillator. The converter on- sists of a 500 MHz bandpass filter, diode mixer and three radial cavities. One avity functions as a bandpass filter for the 1.55 GHz oscillator signal. The ither cavities function as an IF filter and provide a two-pole Butterworth esponse. Both the IF and LO input cavities are adjustable by tuning slugs. he mixer is a single Schottky diode located between the 1.55 GHz scillator cavity and the 2.05 GHz "first IF" cavity. Mixer bias is provided y resistor A5A1R1. Mixer conversion loss is approximately 4 dB.

1.55 GHz OSCILLATOR A7

he 1.55 GHz oscillator is a single transistor oscillator whose frequency is etermined primarily by a radial cavity. The oscillator frequency is tuned ound the center frequency established by the cavity by the positive voltage pplied to the voltage-variable capacitor A7CR1 from the oscillator driver (see ick 5 below). Changes in the voltage level to this Varactor diode provide a frequency tuning range of approximately 4 MHz (refer to paragraph 5-9 for adjustment). The oscillator driver is adjusted to provide an oscillator output f at least +7 dBm and a frequency tuning range of ± 4 MHz. The ground urn lines for the power supply +20 and -10 sense lines are connected to hassis ground adjacent to the 1.55 GHz oscillator. This provides a common eference point for the oscillator and sense grounds.

SERVICE SHEET 3 (cont'd)

1.55 GHz OSCILLATOR DRIVER

The oscillator driver consists of operational amplifier A2U1, transistor A2Q8 and their associated components. Together U1 and Q8 function as a non-inverting operational amplifier. Driver amplifier gain = $1 + A2R31$ over A2R29 in parallel with A2R30 or approximately 2.4. The minimum output voltage is determined by A2R27 "MIN TUNE" while the maximum output is controlled by A2R26 "MAX TUNE" and the front panel TRACK ADJ potentiometer. Adjustments in the oscillator driver correct for minor variations in the sensitivity of the oscillator from unit to unit. These adjustments set the upper and lower tuning range limits for the front panel TRACK ADJ potentiometer. Potentiometer A2R26 is adjusted to provide a 4 MHz frequency tuning of the oscillator from the front panel TRACK ADJ control. Refer to paragraph 5-9 for adjustment procedure.

TROUBLESHOOTING PROCEDURE

When a malfunction has been isolated to the 500 MHz amplifier/PIN diode modulator and driver circuits or to the 1.55 GHz oscillator and converter circuits, perform the appropriate checks below. Refer to Service Sheet 2 for overall troubleshooting procedure.

EQUIPMENT REQUIRED

Digital Voltmeter	HP 3440A/3443A
Frequency Counter	HP 5245L/5254B
Power Meter	HP 432A/8478B
Spectrum Analyzer System	HP 8554B or 8555A
Selectro to BNC Cable	HP 11492-00001
Adapter BNC Jack to BNC Jack	CG-914A/U (HP 1250-0090)
Dc Volt-Ohm-Meter	HP 412A

500 MHz AMPLIFIER/PIN DIODE MODULATOR ASSEMBLY A4

With power removed, disconnect CP1 at A4J1 and W6 at A4J2. Remove the eight screws securing the cover of the A4 assembly. (The A4A1 assembly is mounted on the underside of the A4 cover.) Invert the cover and A4A1 assembly. Connect CP1 to A4J1 and W6 to A4J2. Connect a ground strap between the cover and chassis ground. Position the assembly so that the voltage leads and signal lead are not shorted to ground. Apply power to the Tracking Generator. Measure the voltage drop across each of the PIN diodes. With no 500 MHz input signal to the 500 MHz amplifier, the voltage drop across each diode should be 0.8 \pm 0.2 Vdc. Measure the emitter, base and collector voltages for transistors A4A1Q1 through Q3 and compare with typical values shown on the schematic diagram. Troubleshoot stage or stages with voltage levels that do not compare with typical values shown on schematic. Replace defective component and perform ALC NULL adjustment, paragraph 5-12, and LEVEL adjustment, paragraph 5-13.

SERVICE SHEET 3 (cont'd)

MODULATOR DRIVER CIRCUIT

Check Amplifier and ALC Detector Assembly A3 Service Sheet 4 prior to checking the modulator driver circuit. Connect a shorting strap between test points A2TP1 and A2TP2. Connect a shorting strap between A2TP1 and chassis ground. Apply power to Tracking Generator. Measure and record voltage level at A4C2 (PIN diode drive signal). _____ Vdc Rotate NULL ADJ A2R17 throughout its tuning range. Note and record level to PIN diode modulators, _____ to _____ Vdc. Compare with typical range of +14 to +19.7 Vdc. If the output is not within the typical limits, connect digital voltmeter to junction of A2R15 and R16. Adjust A2R17 for an indicated voltage of +19.3 at the emitter of A2Q5. Troubleshoot the output amplifier using typical voltage levels given for the emitter, base and collector of A2Q5 through Q7 on the schematic diagram. Troubleshoot the differential amplifier A1Q1 through A2Q3 and limiter A2Q4 using the typical voltage levels given on the schematic diagram. When malfunction has been corrected, perform adjustment procedures in paragraphs 5-12 and 5-13. See Figure 8-9 for diode forming instructions.

FIRST CONVERTER ASSEMBLY A5

When a malfunction has been isolated to the first converter, remove lid A5A1MP3 (see illustrated parts breakdown, Figure 8-18). With the 1.55 GHz oscillator signal applied to A5A2 measure mixer bias at test point A5A1TP "A" (inductor A5A1L2). Bias level should be greater than 1.2 Vdc. Polarity can be either positive or negative depending on the direction on diode A5A1CR1. If diode bias is low, check tuning of ADJ 1, check for tightness of screws securing cover A5MP5 to cavity block A5MP4, and check for tightness of screws securing the mixer block A5A1 to the cavity block cover. Monitor bias level during adjustments for indication of fault. If there is no or very low bias voltage remove power from instrument and check diode front-to-back ratio. Use test point A5A1TP "A" and chassis ground for measurement points. Check for a typical front-to-back ratio of 70 to 700 ohms (using HP 412A VTVM with diode in parallel with A4A1R1). For actual diode front-to-back measurement remove the four cap screws A5MP9 and lift the mixer assembly from the cavity block cover. Lift the diode at the A5A1MP2 connector and measure front-to-back ratio. Typically 70 to 200,000 ohms.

NOTE

Replacement of components other than diode A5A1CR1 is not recommended. Replace diode and perform First Converter Adjustment procedures in paragraph 5-11.

If diode replacement does not correct malfunction replace mixer A5A1. See Figure 8-18 for First Converter Assembly Illustrated Parts Breakdown.

1.55 GHz OSCILLATOR ASSEMBLY A7

Field repair of the oscillator assembly is not recommended. Component lead lengths are critical. If components are replaced in the field, note installation

A1 - A7, AT1 - AT3
Tracking Generator
Troubleshooting Block Diagram
SERVICE SHEET 2

Service

TM 11-6625-2866-14&P

Model 8444A

SERVICE SHEET 3 (cont'd)

of component to be replaced and install new component in identical manner. When either assembly or components are replaced, perform oscillator adjustment procedure, paragraph 5-9. See Figure 8-19 for illustrated parts breakdown.

1.55 GHz OSCILLATOR DRIVER

See paragraph 8-30 for operational amplifier troubleshooting procedure. To isolate the operational amplifier from the output amplifier A2Q8, remove the right side panel and disconnect the 91 wire from A7C2 and connect a jumper between A2TP5 and the junction of A2R32 and pin 6 of A2U1. Adjust TRACK ADJ control fully counterclockwise. Compare voltage at A2U1 pin 2 with voltage at pin 3. The voltage levels should not differ more than ± 10 mV and should be approximately 0 Vdc. If voltage levels are correct, adjust A2R27 MIN TUNE for a voltage level of +6.1 Vdc at A2U1 pin 6. If the voltage levels are not correct and/or the MIN TUNE control has no effect on the output level, replace A2U1. Remove jumper from between A2R32/U1 pin 6 and A2TP5. Compare voltage levels at the emitter, base, collector of A2Q8. To check driver voltage gain adjust TRACK ADJ for 1.00 Vdc at A2TP6. Measure level at A2TP5. The level at A2TP5 should change from ± 1 to ± 5 V for a 4 MHz oscillator variation. After repairs have been made connect 91 wire to A7C2 and perform adjustment procedures listed in paragraph 5-9.

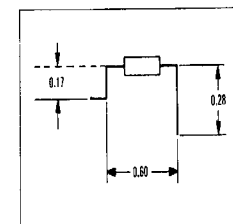

Figure 8-9. Mixer Diode Forming Dimensions in Inches

Model 8444A

TM 11-6625-2866-14&P

Service

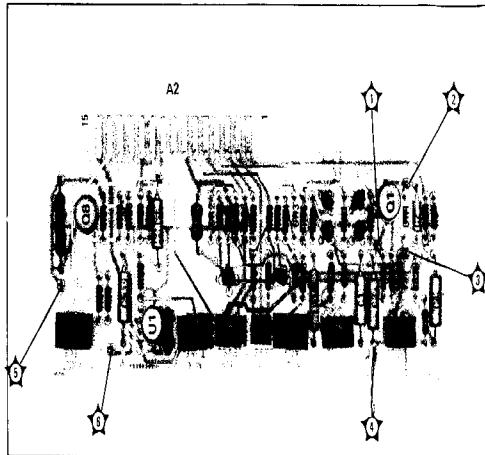

Figure 8-10. Modulator/Oscillator Driver Assv A2 Component Locations

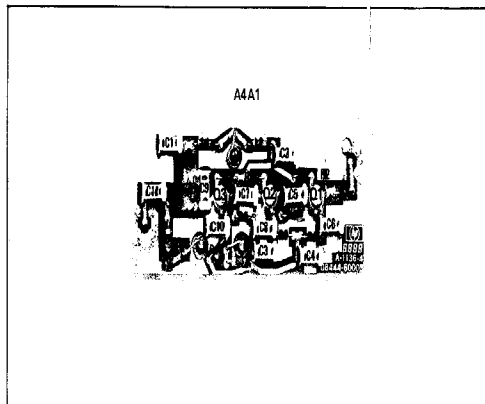

Figure 8-11. Amplifier and Pin Diode Modulator Assv A4A1 Component Locations

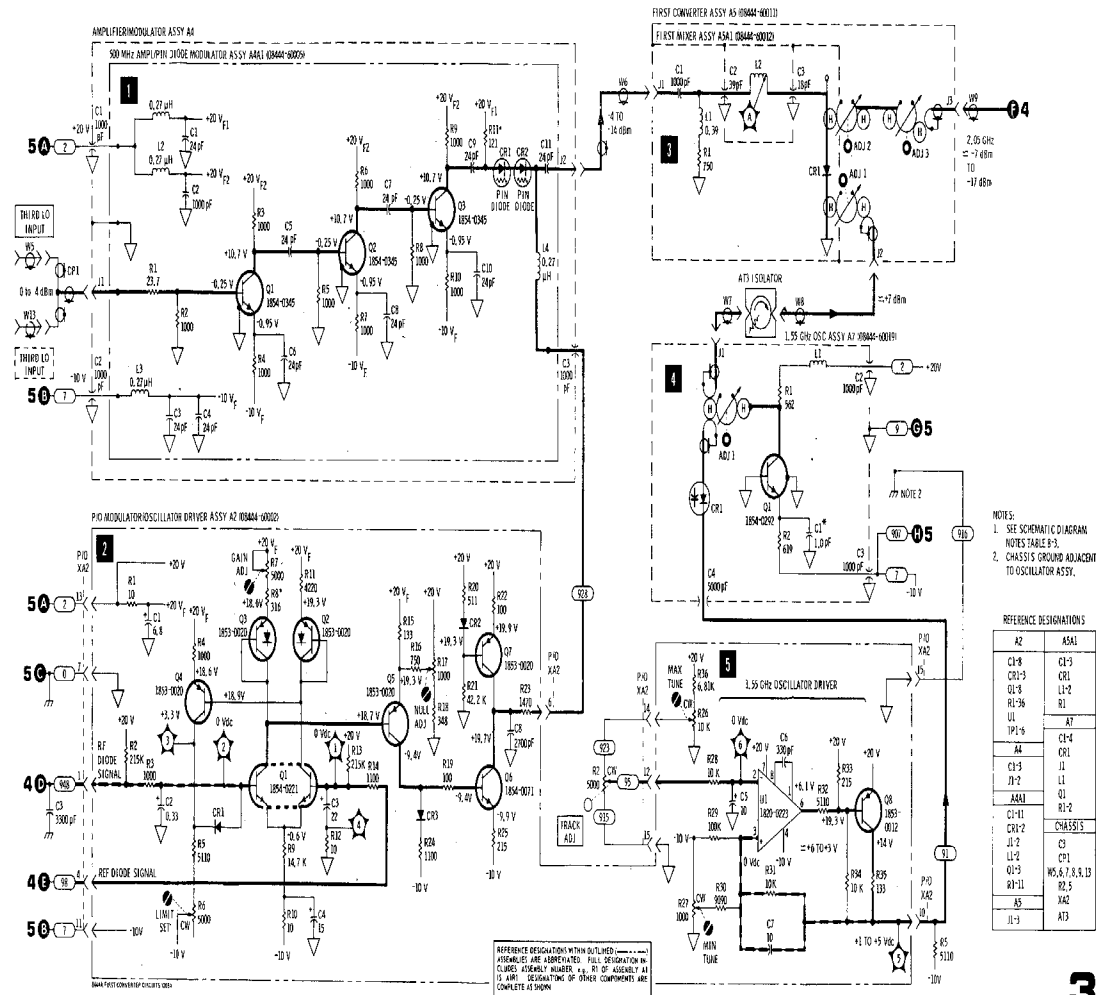

Figure 8-12. First Converter Circuits, Schematic Diagram

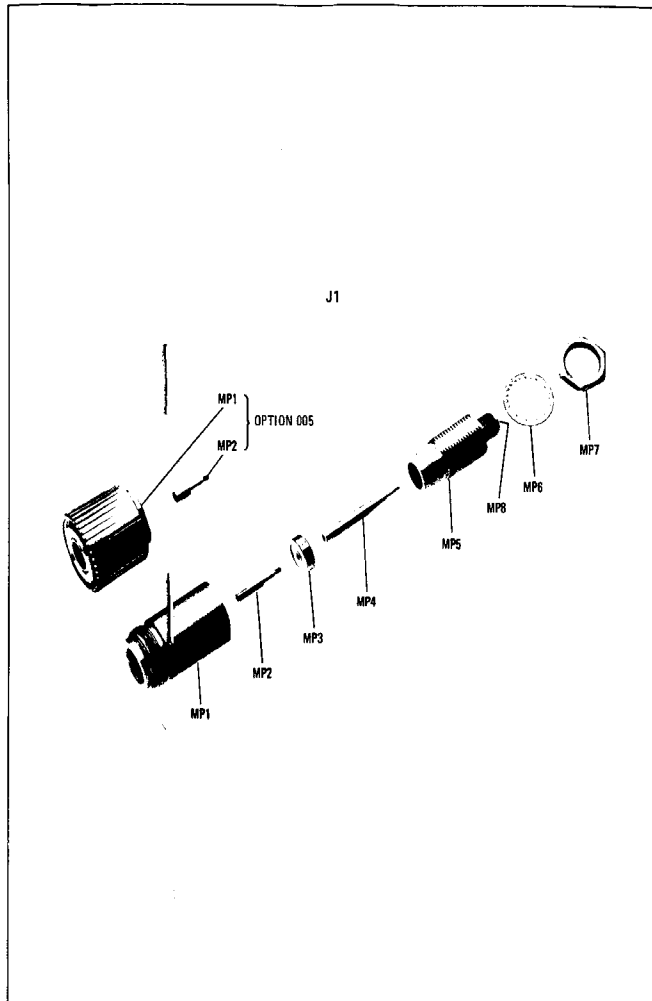

Figure 8-13. J1 RF Output Connector, Exploded View

SERVICE SHEET 4
THEORY OF OPERATION

Service Sheet 4 contains the schematic diagram for the first LO input circuit, the second converter and the amplifier/ALC detector and level control circuits.

1 FIRST LO INPUT CIRCUIT

The first LO input circuit consists of isolators AT1, AT2 and Filter FL1. Isolators AT1 and AT2 allow the first LO input signal to be applied to the second converter while preventing the flow of signals from second converter back to the input. Filter FL1 is a bandpass filter over the 2 to 3.4 GHz frequency range. Signals outside the bandpass frequency range are attenuated.

2 SECOND CONVERTER ASSY A6

The second converter consists of stripline circuitry and a pair of hot carrier diodes. The second converter mixes the 2 to 3.4 GHz LO signal with the 2.05 GHz first converter output signal to produce a 0 to 1.35 GHz signal that tracks the tuning of the LO input signal. Conversion loss in the second converter is typically 7 dB. The converter assembly is a sealed unit and should be repaired by replacing the entire A6 Assembly.

3 AMPLIFIER AND ALC DETECTOR ASSEMBLY A3

The amplifier and detector assembly contains large scale integrated (LSI) circuits consisting of a 3 dB attenuator, a 1.3 GHz low-pass filter, a wideband amplifier, a level detector circuit, a 1.4 GHz low-pass filter and a dc blocking capacitor. The 0 to 1.35 GHz signal from the second converter is applied through a 3 dB attenuator (for impedance matching), and a 1.3 GHz low-pass filter to the wideband amplifier. The amplifier provides approximately 26 dB gain over the frequency range of 500 kHz to 1.3 GHz. The output of the wideband amplifier is applied through a level detector circuit and a 1.4 GHz low-pass filter to the RF output connector. The level of the RF output is sampled and applied to the modulator (PIN diode) driver as the RF diode signal. A reference signal (controlled by the front panel LEVEL control and the internal 0 and -10 dBm adjustments) is applied through a second diode in the level detector circuit to the modulator driver. The level of the reference signal and the ALC circuitry is adjusted to provide an output level of 0 to -10 dBm.

4 LEVEL CONTROL CIRCUITRY

The level control circuit is a resistive divider network that establishes the level of the reference diode signal. The front panel LEVEL control adjusts the reference signal level to the ALC circuitry to provide control of the RF output level range of 0 to -10 dBm. Refer to paragraph 5-13 for calibration of the 0 and -10 dBm points.

TROUBLESHOOTING PROCEDURE

Except for the ALC level control circuitry refer to Service Sheet 2 for troubleshooting procedure.

EQUIPMENT REQUIRED

Spectrum Analyzer System HP 8554B or 8555A System
Digital Voltmeter HP 34440A/34443A

SERVICE SHEET 4 (cont'd)

1, 2, 3 See Service Sheet 2.

4 Perform Preset Adjustment Procedures, paragraph 4-7 or 4-9 Spectrum Analyzer SCAN WIDTH to ZERO. Set Tracking Gen LEVEL to 0 dBm. Measure voltage level at junction of the (958), (98 (948) wires with the connection pins of the A3 assembly. Levels shot within ± 50 mVdc of the level listed below.

LEVEL	958	98	948
0 dBm	-50 mVdc	+240 mVdc	+350 mVdc
-10 dBm	0 mVdc	+300 mVdc	+400 mVdc

Note voltage drop across reference diode.

Typically 300 mVdc

If voltage levels are not within ± 50 mVdc perform adjustment procedure paragraph 5-12 and 5-13 and repeat measurement procedure above.

REMOVAL AND REPLACEMENT PROCEDURES

See wiring detail for Amplifier and Detector Assembly A3. Microcircuit with serial numbers below 00100 have wires (98) and (958) reversed units with serial numbers above 00101. Connect assembly according wiring detail and serial number. Replacement assemblies are shipped ground clips installed on the rf diode and reference diode pins. Remove from the replacement assembly and install on unit being returned for r

A2, A4, A4A1, A5, A5A
First Converter Circuits,
Schematic Diagram
SERVICE SHEET 3

Model 8444A

TM 11-6625-2866-14&P

Service

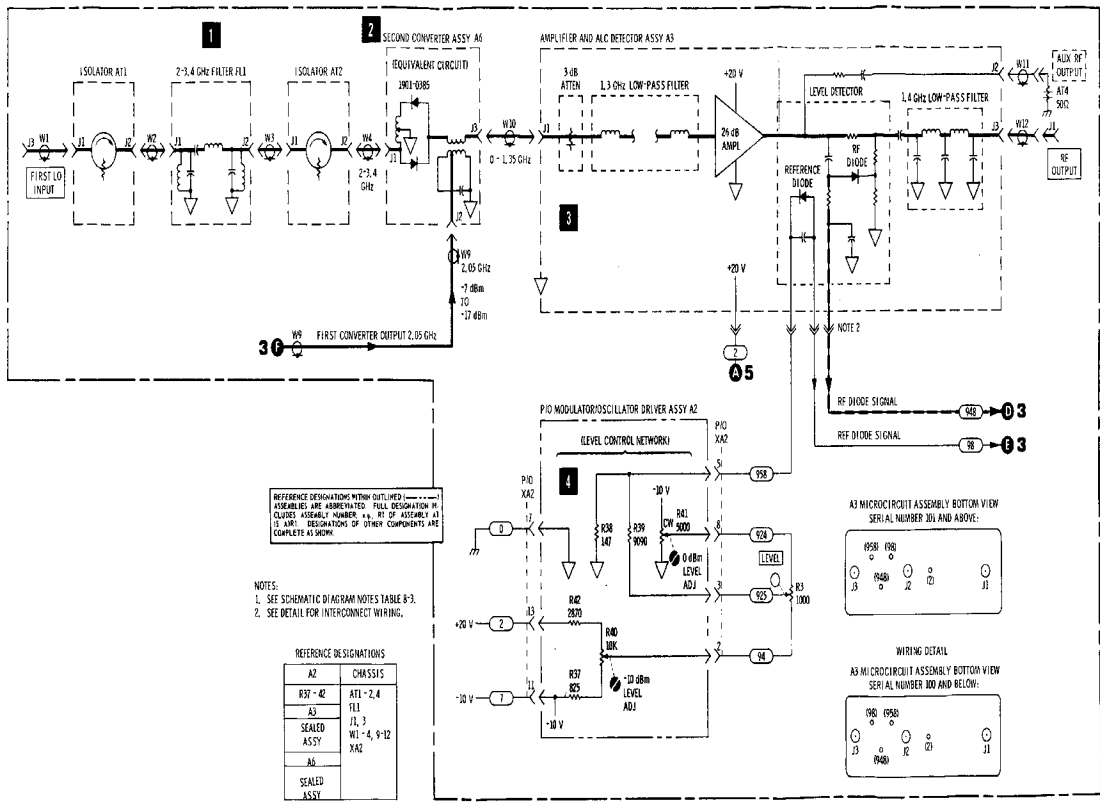
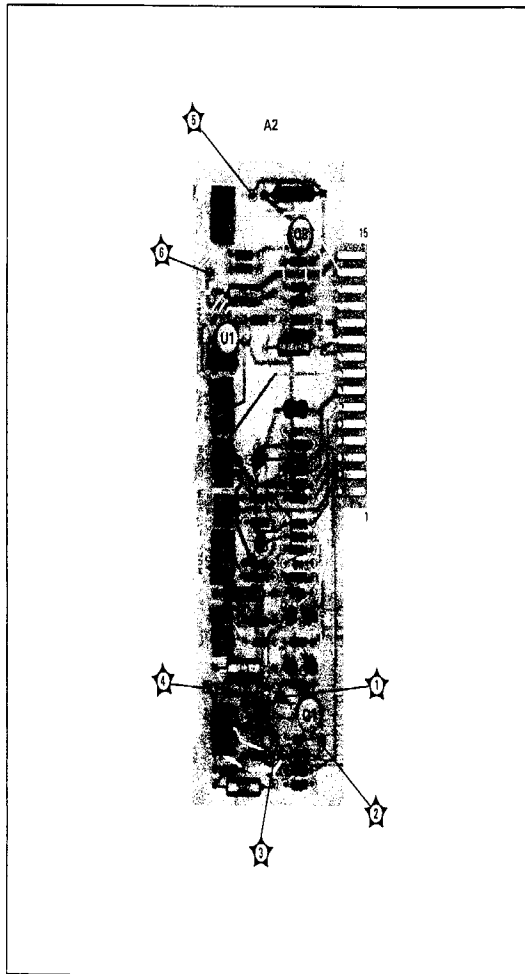

4

Figure 8-15. Second Converter Circuit, Schematic Diagram

Figure 8-14. A2 Modulator/Oscillator Driver Assy, Component Location

SERVICE SHEET 5

THEORY OF OPERATION

Service Sheet 5 contains the schematic diagram for the +20 and -10 volt power supplies, the input line voltage circuit and a wiring diagram of the input line switch and power line module.

1 INPUT LINE VOLTAGE CIRCUIT

Both schematic and wiring diagram are shown for the input line voltage circuit. For 230 volt operation replace the 0.5 ampere fuse with a 0.25 ampere fuse. The power line module and ON/OFF switch wiring diagram provides a rear view for circuit tracing or component replacement.

2 +20 VOLT POWER SUPPLY

The +20 volt supply consists of bridge rectifier A1CR1-CR4, series regulator Q1, filter C1, driver A1Q3, current source A1Q1/Q2, foldback current limiter A1Q4, sense amplifier A1U1 and over-voltage and reverse voltage protection circuit consisting of A1Q5 and A1CR6-CR10. The 28V rms at 0.5 Amp input from power transformer T1 is rectified by diodes A1CR1-CR4 and filtered by C1 to provide a +40 volt unregulated source to series regulator Q1. At initial turn-on driver transistor A1Q3 and current source A1Q1/Q2 provide a +14.5 volt signal to the base of Q1 resulting in an output of approximately +13.8 volts. The low output voltage is sensed by sense amplifier A1U1 which then provides the additional turn-on signal to driver A1Q3. Adjustment of the +20 volt output is provided by +VOLTS adjustment A1R14. Fold-back current limiting is provided by A1Q4 with over current protection provided by A1Q5. Over-voltage for both the +20 and -10 volt supplies is provided by a "crow-bar" circuit consisting of A1CR8 -- CR10 and A1Q5. Should either supply exceed the breakdown voltage of the diodes the silicon controlled rectifier is triggered on, shorting the output of both supplies together. Diodes A1CR6 and CR7 provide reverse voltage protection. A1R9 and the front panel MANUAL SCAN control R1 provide the 0 to +10V output for MANUAL SCAN operation.

3 -10 VOLT POWER SUPPLY

The -10 volt supply consists of bridge rectifier A1CR12-CR15, filter C2, series regulator Q2, driver A1Q7, fold-back current limiter A1Q6 and sense amplifier A1U2. The unregulated output of the bridge rectifier is filtered by C2 and regulated by Q2. +20 volts from the positive supply provides the reference for the sense amplifier A1U2. Precision resistors between the +20 volts and the -10 sense line reference the negative supply to the positive supply. The driver and current limiter function in the same manner as the driver and limiter in the positive supply.

TROUBLESHOOTING PROCEDURE

CAUTION

Before troubleshooting the power supplies, disconnect the +20 volt red (2) wire from the Amplifier and ALC Detector Assembly A3.

When a malfunction has been isolated to the power supply or line input circuits or to isolate a malfunction in the circuits, perform the following procedure.

A2, A3, A6, AT1, AT2, FL1
 Second Converter Circuits,
 Schematic Diagram
 SERVICE SHEET 4

SERVICE SHEET 5 (cont'd)

EQUIPMENT REQUIRED

Volt-Ohm-Ammeter HP 412A
 Digital Voltmeter HP 3440A/3443A

1 INPUT CIRCUIT

Check the input circuits against the wiring diagram and schematic diagram.

2 +20 VOLT SUPPLY

Turn LINE ON/OFF switch to OFF. Remove top cover and disconnect the +20 volt red (2) wire from microcircuit A3. Check fuses A1F1 and F2. If fuse A1F1 is blown, check power transistor Q1 for a short. If fuse A1F2 is blown, check power transistor Q2 for a short. After replacing fuse, apply power and check voltage at A1TP1 for +20 volts. If the voltage level is between +10 and +15 Vdc, troubleshoot operational amplifier A1U1 (paragraph 8-30) and associated circuitry. If the voltage output is less than +1 volt, remove silicon controlled rectifier A1CR10. If the output of both supplies is normal, check A1CR8, A1CR9, and A1Q5 (removing A2 assembly for access to A1 components). Also check for a short circuit external to the power supply and for a shorted A1C5. Check A1C5 by measuring voltage drop across A1R10. It should be 0 Vdc. (A 100 mV drop indicates a shorted capacitor A1C5.) If the output voltage is over +20 volts and cannot be corrected with the +VOLTS adjustment A1R14, ground anode of A1CR5 and check for an output level of +10 to +15 volts, indicating associated circuitry is functioning properly. If it is outside this range check emitter-base voltages on A1Q1, A1Q2, and A1Q3. Remove ground from anode of A1CR5 and perform adjustment procedures in paragraph 5-8.

3 Troubleshoot the -10 volt supply in a similar manner. Check input to operational amplifier, remove Q2 and check voltage at emitter of A1Q7, remove A1Q7 and repeat voltage measurement at emitter of A1Q7. Check A1C9 for short.

Model 8444A

TM 11-6626-2866-14&P

Service

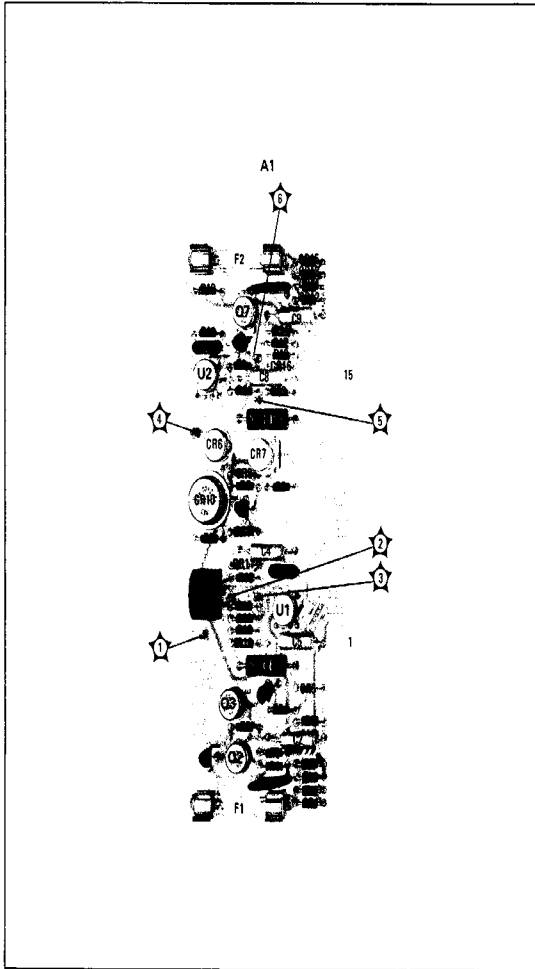

Figure 8-16. A1 Power Supply Assy, Component Location

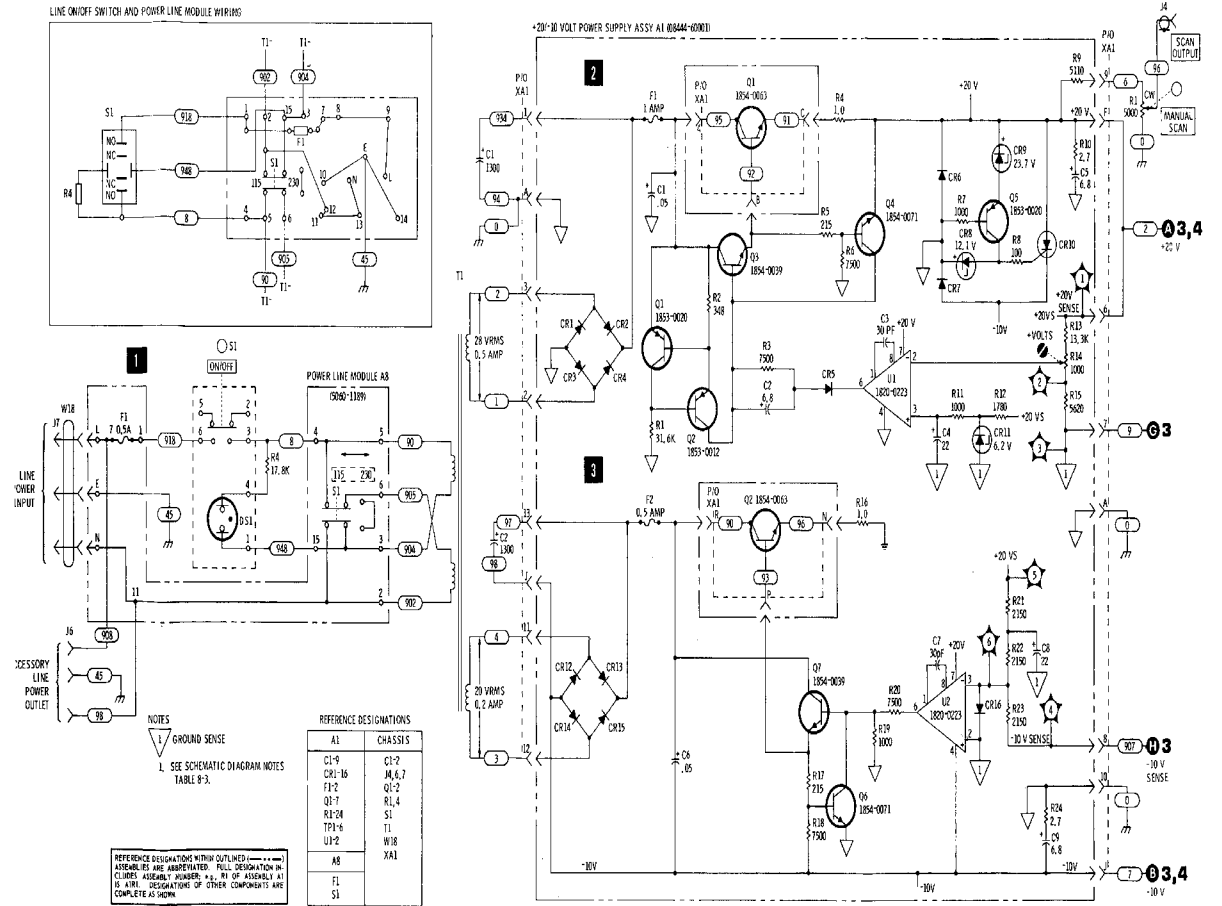
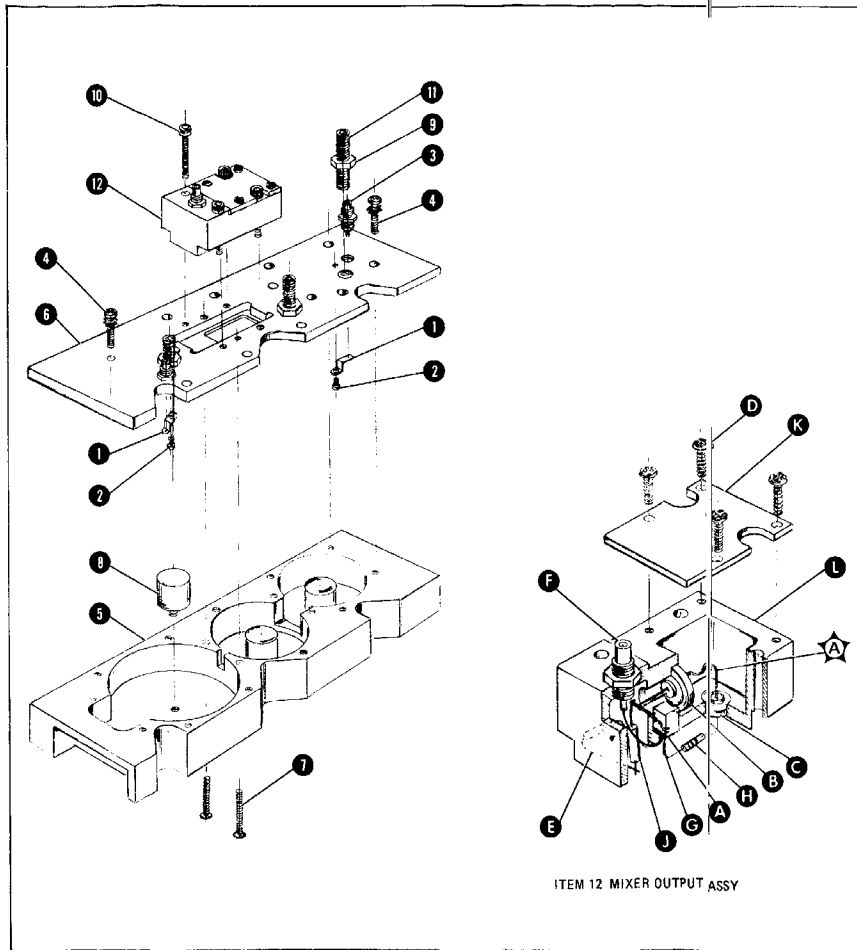

Figure 8-17. Power Supply and Input Circuit, Schematic Diagram

Service

TM 11-6625-2866-14&P

Model 8444A



Item No.	Ref. Des.	Description	HP Part No.	Qty
1	A5MP1	INPUT-OUTPUT LOOP	08555-00033	2
2	A5MP2	SCREW: PAN HD SLOT DR 0-80 X 0.88" LG.	0516-0005	2
3	A5J1	CONNECTOR: RF 50-OHM SCREW ON	1250-0829	3
3	A5J2	CONNECTOR: RF 50-OHM SCREW ON	1250-0829	3
3	A5J3	CONNECTOR: RF 50-OHM SCREW ON	1250-0829	3
4	A5MP3	SCREW: PAN HD POZI DR 5-40 X 0.5" LG	2200-0111	14
5	A5MP4	CAVITY BLOCK: FIRST CONVERTER	08555-20035	1
6	A5MP5	COVER: CAVITY BLOCK	08444-20012	1
7	A5MP6	SCREW: FLAT HD POZI DR 4-40 X 0.874" LG	2200-0172	2
8	A5MP7	CENTER POST: CAVITY	08444-20007	1
9	A5MP8	NUT: HEX STL 10-32 X 3/8"	2740-0001	3
10	A5MP9	SCREW: SOCKET CAP 4-40" THREAD	3030-0151	4
11	A5MP10	SCREW: SET 10-32" UNF-2A THREAD	3030-0397	3
12	A5A1	MIXER: OUTPUT ASSY	08444-60012	1
A	A5A1C1	C: FXD CER 1000 PF 20% 100 VDCW	0160-2327	1
B	A5A1C2	C: FXD MICA 39 PF 5% 250 VDCW	0160-2327	1
C	A5A1C3	C: FXD MICA 18 PF 5% 250 VDCW	0160-3861	1
D	A5A1MP1	SCREW: PAN HD POZI DR 2-56 X 0.25" LG	0520-0128	4
E	A5A1R1	R: FXD MET FLM 750 OHM 2% 1/8W	0698-7233	1
F	A5A1J1	See A5J1 ABOVE		
G	A5A1MP2	CONNECTOR: SINGLE CONTACT	1251-1556	1
H	A5A1CR1	DIODE: HOT CARRIER	1901-0633	1
J	A5A1L1	COIL: CHOKE 0.39 UH 10%	9100-2254	1
K	A5A1MP3	LID: RESONATOR HOUSING	08555-00031	1
L	A5A1MP4	RESONATOR HOUSING	08555-20036	1

Figure 8-18. A5 First Converter Assembly, Illustrated Parts Breakdown (1 of 2)

Figure 8-18. A5 First Converter Assembly, Illustrated Parts Breakdown (2 of 2)

A1, A8
Power S
SERVIC
ply and Input Circuit
SHEET 5

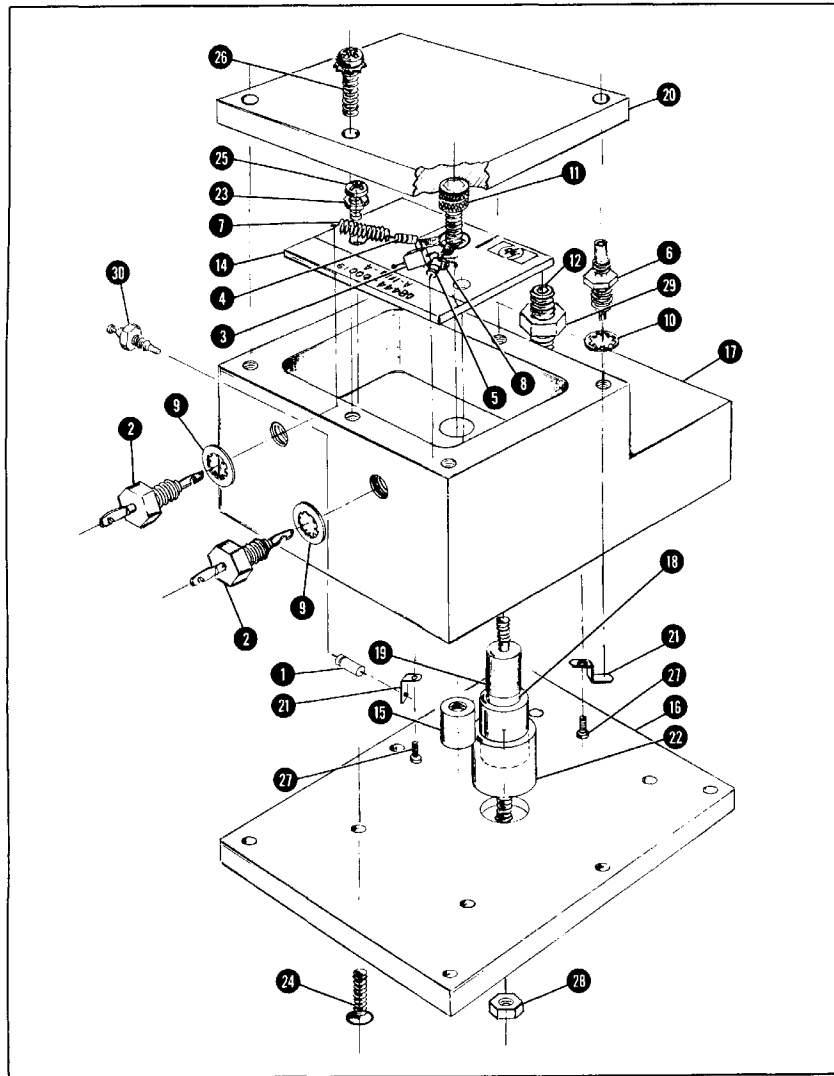

Figure 8-19. A7 1.55 GHz Oscillator Assembly, Illustrated Parts Breakdown (1 of 2)

Item No.	Ref. Des.	Description	HP Part No.	Qty
1	A7CR1	DIODE: VOLTAGE VAR 6.8 pF	0122-0245	1
2	A7C2/C3	C: FXD 1000 pF 500 VDCW	0160-0345	2
3	A7C1	C: FXD 1.0 pF 0.1%	0160-3827	1
4	A7R1	R: FXD 562 OHM	0698-7230	1
5	A7R2	R: FXD 619 OHM	0757-0418	1
6	A7J1	CONNECTOR: RF	1250-0829	1
7	A7L1	SPRING: COMPRESSION	1460-0103	1
8	A7Q1	TRANSISTOR: SI NPN	1854-0292	1
9		WASHER: LOCK 0.211 DIA	2190-0057	2
10		WASHER: LOCK 0.191 DIA	2190-0124	1
11		SCREW: SOCKET CAP 8-32 X 0.625	3030-0047	1
12		SCREW: SET 10-32 X 1.000 LG	3030-0397	1
13		DELETED		
14		PC BOARD: OSCILLATOR BLANK	08444-20003	1
15		INSULATOR	08444-20006	1
16		COVER: OSC HOUSING BOTTOM	08444-20008	1
17		HOUSING: OSCILLATOR	08444-20010	1
18		DIELECTRIC: CAPACITOR	08444-20013	1
19		INNER ELEMENT: CAPACITOR	08444-20015	1
20		COVER: OSCILLATOR HOUSING TOP	08444-20028	1
21		INPUT/OUTPUT LOOP	08555-00033	1
22		CAPACITOR: OUTER ELEMENT	08555-20040	1
23		WASHER: LOCK NO. 4	2190-0003	2
24		SCREW: MACHINE 4-40 X 0.438 LG	2200-0109	6
25		SCREW: MACHINE 4-40 X 0.250 LG	2200-0139	2
26		SCREW: MACHINE 4-40 X 0.375 LG	2200-0167	6
27		SCREW: PAN HD 0-80 X 0.125 LG	0516-0003	1
28		NUT: HEX 6-32	2420-0003	1
29		NUT: HEX 10-32	2740-0002	1

Figure 8-19. A7 1.55 GHz Oscillator Assembly, Illustrated Parts Breakdown (2 of 2)

APPENDIX A

SERVICE NOTE - P-0960-2038, P-5086-6025

HP MODEL 8444A TRACKING GENERATOR

Serials Prefixed 1147A and Below

REQUIRED MODIFICATION WHEN REPLACING A3

When replacing the A3 Amplifier Detector Assembly in the HP Model 8444A, serials prefixed 1147A and below, a capacitor C3, 3300 pF, HP Part No. 0160-0155, is a required addition for proper instrument operation. The capacitor is electrically connected between the RF Diode Signal line and ground. For easiest installation, connect the capacitor between connector pins XA2-1 and XA2-7. Pin 1 is located nearest the instrument front panel.

APPENDIX B

SERVICE NOTE - P-08444-60019

HP MODEL 8444A TRACKING GENERATOR

Serials Prefixed 1147A and Below

REPLACEMENT FOR A7 08444-60003

The HP Part No. 08444-60019 assembly is the recommended replacement for the old 08444-60003 A7 assembly. Since the old and new A7 assemblies are not directly interchangeable, minor modifications are required when installing the new A7. The additional parts required for the modification are:
(one each)

HP 0757-0438 5.11K, 1%, 1/8 W Resistor
HP 0757-0439 6.81K, 1%, 1/8 W Resistor
HP 0757-0465 100K, 1%, 1/8 W Resistor
HP 8150-0449 30" Red No. 24 AWG Wire

MODIFICATIONS

1. A7 hookup (refer to Figures 8-12 and 8-19):
 - a. Connect the wht-brn wire to new A7C4.
 - b. Add red wire; connect between +20V (XA1-6) and A7C2.

- c. Connect violet and wht-blk-violet wires to A7C3.

2. Component changes:

- a. Add R5, 5.11K, 0757-0438 between connector pins XA2-10 and unused XA2-12; then short pins XA2-12 and XA2-11 (-10V) together.
- b. Replace A2R29 with 100K, 0757-0465.
- c. Replace A2R36 with 6.81K, 0757-0439.

CALIBRATION

To calibrate the new A7 assembly, follow the 1.55 GHz Oscillator Power Level, Frequency Check and Adjustment procedure, pages 5-3 to 5-5.

APPENDIX C

SERVICE NOTE - 8444A-1

HP MODEL 8444A TRACKING GENERATOR

Serials Prefixed 1147A and Below

IMPROVED POWER SUPPLY STABILITY

The +20V power supply stability can be improved by changing A4A1C2 from 24 pF to 1000 pF, HP Part No. 0160-3456. The new value eliminates any oscillation tendencies and is a recommended modification for all instruments with serials listed above.

APPENDIX D

MODEL 8444A TRACKING GENERATOR, OPTION 058

D-1. INTRODUCTION

D-2. This appendix explains the use of an 8444A Tracking Generator with an 8558B/180 Spectrum Analyzer system when Option 058 circuitry is added to the 8444A. The Tracking Generator is designed to generate a CW tracking signal for an 8555A/8552/140 Spectrum Analyzer system when operating in the range of 0.5 to 1300 MHz. With Option 058 circuits added, a 0.5 to 1300 MHz CW tracking signal can also be generated by an 8444A when it is coupled to an 8558B/180 Spectrum Analyzer system.

D-3. DESCRIPTION

D-4. To provide a tracking signal for an 8555A/8552/140 Spectrum Analyzer, an 8444A Tracking Generator must be fed a 2.05 to 4.1 GHz tuned oscillator signal from the 8555A First LO, plus a 500 MHz signal from the 8555A Third LO. When mixed with the internal 1.55 GHz oscillator in the 8444A, a 0.5 to 1300 MHz tracking signal output is produced.

D-5. To develop a 0.5 to 1300 MHz tracking signal for an 8558B/180 Spectrum Analyzer/Display system, a 2.05 to 3.55 GHz First LO is available from the 8558B, but no 500 MHz LO is used in this instrument. Option 058 consists of a 500 MHz oscillator for the 8444A. This 500 MHz signal is brought out on a separate BNC connector on the rear panel of the 8444A, directly above the THIRD LO INPUT BNC connector. When the 8444A is used with an 8558B/180 Spectrum Analyzer system, the two rear panel BNC connectors are interconnected with a short BNC cable. With the First LO from the 8558/B plus its own 500 MHz LO signal, the 8444A can provide a 0.5 to 1300 MHz tracking signal for the 8558B Spectrum Analyzer system.

D-6. MANUAL CHANGES TO INCORPORATE OPTION 058

D-7. Section I.

D-8. 8444A System Specifications with Option 058 added are listed in Table D-1.

Table D-1. 8444A System Specifications with Option 058

SPECIFICATIONS	
<p>These specifications apply to the 8444A Option 058 when used with the 8558B Spectrum Analyzer ONLY. Specifications of the 8444A Option 058 when used with the 8554B and 8555A Spectrum Analyzers can be found in Table 1-1 of the 8444A manual.</p>	
<p>Swept Frequency Response Measurements</p> <p>Dynamic Range: <90 dB from Spectrum Analyzer 1 dB gain compression point to average noise level (approximately --10 dBm to -100 dBm).</p> <p>Average Noise Level: -107 dBm with 10 kHz Resolution bandwidth.</p>	<p>Absolute Amplitude Calibration Range</p> <p>Spectrum Analyzer:</p> <p>Log: From -117 dBm to +30 dBm, 10 dB/div on a 70 dB display or 1 dB/div on an 8 dB display.</p> <p>Linear: From 2.2 μV (-100 dBm) to 7.1V (+30 dBm), full scale in 10 dB steps.</p>

Table D-1. (Continued)

Frequency Range: 500 kHz to 1300 MHz

Scan Width: (Determined by Spectrum Analyzer Controls):

Per Division: 14 Calibrated Scan Widths from a 5 kHz/div to 100 MHz/div in a 2, 5, 10 sequence.

"O" Scan: Analyzer is a fixed tuned receiver.

Frequency Resolution: 3 kHz.

Stability:

Residual FM (peak-to-peak): 1 kHz for time <0.1 sec.

Amplitude Accuracy:

System Frequency Response: +1.50 dB (0.5 dB for 8444A-058, +10 dB for 8558B).

SWEEP/CW GENERATOR

Frequency: Controlled by Spectrum Analyzer. Range 500 kHz to 1300 MHz. Scan widths are determined by Spectrum Analyzer controls.

Frequency Accuracy: Same as the 8558B. Can be improved using an external counter.

Flatness: +0.5 dB.

Spectral Purity:

Residual FM (peak-to-peak): 1 kHz for time <0.1 sec.

Harmonic Distortion: 25 dB below output level/(typical).

Nonharmonic (spurious) Signals: 35 dB below output level.

Long Term Stability: Drift typically less than 30 kHz/10 min. (20 kHz for 8558B, 10 kHz for 8444A) when stabilized after 2-hour warm-up

Sweep Width: 50 kHz to 1000 MHz.

D-9. SECTION III OPERATION

D-10. Add the following 8444A Option 058 Tracking Generator Operation information when using the 8558B Spectrum Analyzer.

1. Check that the 115/230V switch is set to correspond with the available line voltage. Refer to Figure 3-2, steps 4 through 8, for switch and fuse information.
2. Apply power to Tracking Generator and Spectrum Analyzer.
3. Turn Spectrum Analyzer INTENSITY control fully CCW.
4. Allow instruments to warm up for at least 30 minutes.
5. Perform Spectrum Analyzer "Operation Check." Refer to 8558B Spectrum Analyzer Operating Manual.

Sweep Rates: Selected by Sweep Time per Division on Spectrum Analyzer. 16 internal scan rates from 0.1 m Sec/div to 10 sec/div in a 1, 2, 5 sequence. Manual Sweep is available with a front panel control of the 8558B. Auto Sweep is automatically controlled by FREQ SPAN/DIV, RESOLUTION BW, and VIDEO FILTER settings

PRECISION FREQUENCY MEASUREMENTS

An external counter output is provided on the 8444A for precision frequency measurements. The frequency of unknown signals as well as the frequency of any point on a frequency response curve can be measured. The use of the 5300A/5303A Counter is suggested for frequency measurements to 500 MHz and the 5245L/5254C Counter for measurements to 1300 MHz

Frequency Accuracy (Tracking Generator Output): For unknown signals, typically less than +3 kHz frequency error after tracking adjustment with 10 kHz BW (Tracking drift typically 10 kHz/10 min. after 2-hour warmup.)

For points on frequency response curve, counter accuracy \pm Residual FM (1 kHz peak-to-peak for time <0.1 sec)

Counter Mode of Operation:

Manual Scan: Scan determined by front panel control of 8558B

"O" Scan: Analyzer is a fixed-tuned receiver. Counter reads center frequency to accuracy of tracking drift

Counter Output Level: Nominally 0.1 Vrms

NOTE

All above changes in specifications apply to use with an 8558B only

6. Set Spectrum Analyzer LOG/LINEAR control to LOG, and BANDWIDTH to 300 kHz.
7. Set OPTIMUM INPUT dBm to 0, and REF LEVEL dBm to 0 dBm.
8. Make the following interconnections between tracking Generator and Spectrum Analyzer.
 - a. 8558B FIRST LO OUTPUT to 8444A FIRST LO INPUT.
 - b. 8558B RF OUTPUT to the 8444A RF INPUT.
 - c. Jumper 500 MHz OUTPUT to THIRD LO INPUT (Rear Panel 8444A-058).
9. Check that the Spectrum Analyzer controls are set as follows:

INTENSITY 12 o'clock (approx.)
 FREQUENCY MHz..... 30 MHz
 RESOLUTION BW300 kHz
 FREQ SPAN/DIV 50 kHz
 BASE LINE CLIPPER CCW
 SWEEP TIME/DIV 5 MILLISECONDS
 dB/DIV-LIN 10 dB/DIV
 OPTIMUM INPUT dBm 0
 REF LEVEL dBm..... 0dBm
 REF LEVEL FINE 0
 VIDEO FILTER.....2 o'clock
 SWEEP TRIGGERLINE

10. Set Tracking Generator LEVEL control to 0 dBm and adjust TRACK ADJ for maximum signal amplitude indication on CRT display.
11. Adjust Spectrum Analyzer REF LEVEL FINE control or Tracking Generator LEVEL control to position signal on CRT LOG REF level graticule line. (System calibrated at 30 MHz with an amplitude accuracy of +0.5 dB.)
12. Set Spectrum Analyzer to scan desired frequency range.
13. Insert device to be tested between Tracking Generator RF OUTPUT and Spectrum Analyzer RF INPUT.
14. Set Spectrum Analyzer Sweep Time to MAN.
15. Rotate Spectrum Analyzer MANUAL SWEEP control clockwise to tune system through selected frequency range.
16. For automatic scanning, set SCAN MODE switch to INT and SWEEP TIME/DIV to desired scan time.

D-11. SECTION IV, PERFORMANCE TESTS

D-12. Add the following: Proper operation of the SPECIAL 500 MHz Oscillator after a one-hour warmn-up may be checked in the following manner:

1. Connect the 500 MHz OUTPUT (Third LO OUTPUT, Figure D-2) on the rear panel of the 8444A to a 432A Power Meter.
2. Adjust "L.O. PWR" on Oscillator Assembly (A9) to set oscillator output power to +4 dBm + .5 dB.
3. Disconnect oscillator output from power meter and connect to 5254C Frequency Counter.
4. Adjust "FREQ ADJ" on Oscillator to set frequency to 500 MHz + 200 kHz.

5. Check power output again and re-adjust if necessary.
6. Repeat steps 2 through 5 until the two test limits are both met.

D-13. SECTION VI, REPLACEABLE PARTS

Page 6-4, Table 6-2:
Add the following parts:

Table D-2. Replaceable Parts

Reference Designation	HP Part Number	Qty	Description	Mfr Code	Mfr Part Number
A9	0844460024	1	500 MHz OSCILLATOR ASSEMBLY	28480	08444-60024
A9C1	01602357	2	C;FXD 100OPF +80 -20% 500WVDC CER	28480	0160-2357
A9C2	0160-2357		C;FXD 100O0PF +80 -20% 500WVDC CER	28480	0160-2357
A9J1	1250-0828	1	CONNECTOR: 50 OHM	28480	1250-0828
A9L1	0855400015	1	COUPLING: LO OUTPUT	28480	08554-00015
A9R1	06987200	1	R;FXD 31.6 OHM 2%.05W	24546	C3-1/8-TOO-31 R6-G
A9A1	0844460020	1	OSCILLATOR ASSEMBLY: 500 MHz	28480	08444-60020
A9A1C1	0160-2247	1	C:FXD 3.9PF f.25PF 50OWVDC CER	28480	0160-2247
A9A1C2	0121-0414	1	C:VAR TRMR 1.9 - 8.5PF; AIR	74970	189-253-5 MODIFIED
A9A1L1	0855400007	1	INDUCTOR: 500 MHz OSC.	28480	08554-00007
A9A1Q1	1854-0323	2	TRANSISTOR: NPN	28480	1854-0323
A9A1Q2	1854-0323		TRANSISTOR: NPN	28480	1854-0323
A9A1R1	06983447	1	R: FXD 422 OHM 1% 1/8W	16299	C4-1/8-TO-422R-F
A9A1R2	0757-0280	2	R: FXD 1K OHM 1% 1/8W	24546	C4-1/8-TO-1001-F
A9A1R3	0757-0280		R: FXD 1K OHM 1% 1/8W	24546	C4-1/8-TO-1001-F
A9A2	0844460031	1	POWER SUPPLY FILTER ASSEMBLY	28480	08444-60031
A9A2C1	0160-2055	2	C: FXD.01 U F +80 -20% 10WVDC CER	28480	0160-2055
A9A2C2	0160-2055		C: FXD .01U F +80 -20% 10OWVDC CER	28480	0160-2055
A9A2C3	0180-00492		C: FXD 20UF +75 -10% 50WV DC AL	56289	300206G050CC2
A9A2C4	01800049		C: FXD 20UF +75 -10% 50WVDC AL	56289	300206G050CC2
A9A2CR1	1901-00402		DIODE: SWITCHING 2NS 30V 50MA	28480	1901-0040
A9A2CR2	1901-0040		DIODE: SWITCHING 2NS 30V 50MA	28480	1901-0040
A9A2Q1	185404042		TRANSISTOR: NPN	28480	1854-0404
A9A2Q2	1854-0404		TRANSISTOR: NPN	28480	1854-0404
A9A2R1	2100-1775	1	R:VAR 5K OHM 5% WW	28480	2100-1775
A9A2R2	06983155	2	R:FXD 4.64K OHM 1% 1/8W	16299	C4-1/8TO-4641-F
A9A2R3	06983155		R: FXD 4.64K OHM 1% 1/8%	16299	C4-1/8-TO-4641-F
A9A2R4	06980083	1	R: FXD 1.96K OHM 1% 1/8W	16299	C4-1/8-TO-1961-F
A9A2R5	06980082	1	R: FXD 464 OHM 1% 1/8W	16299	C4-1/8-TO-4640-F
W19	08444-60025	1	CABLE: COAX; 500 MHz OUTPUT	28480	0844460025

D-14. SECTION VIII, SERVICE

D-15. Description of Option 058: A two-transistor, 500-MHz fixed-tuned local oscillator with power supply processing circuits, Assembly A9, is added to the Main Deck of an 8444A. The 500 MHz LO Output is brought out through a BNC connector on the rear panel directly above the BNC connector serving as the output of the THIRD LO INPUT. Power supply voltages for the A9 500 MHz Oscillator Assembly are taken from the PC connector XA1 on the bottom of the 8444A Main Deck.

D-16. Figure D-1 is a top view of the 8444A including the Option 058 500 MHz A9 Oscillator Assembly with its BNC connector on the rear panel.

D-17. Figure D-2 shows the rear panel of an 8444A Option 058 with the added 500 MHz OUTPUT BNC connector above the THIRD LO INPUT connector.

D-18. Figure D-3 is a schematic diagram of the 500 MHz Oscillator used with Option 058, a capacitance multiplier used as additional filter for the 8444A +20V power supply, and an adjustable current regulator for the -10V 8444A power supply.

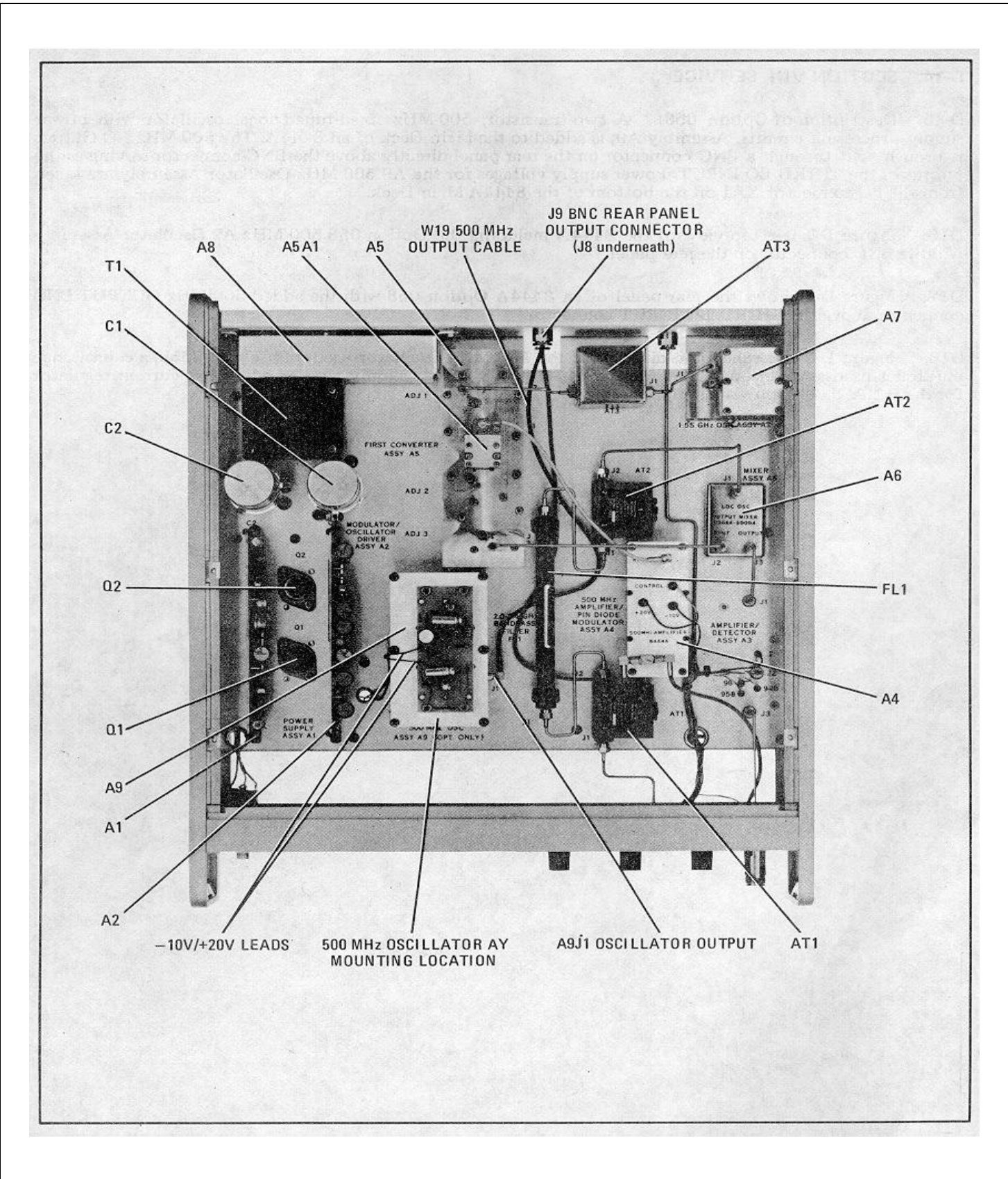
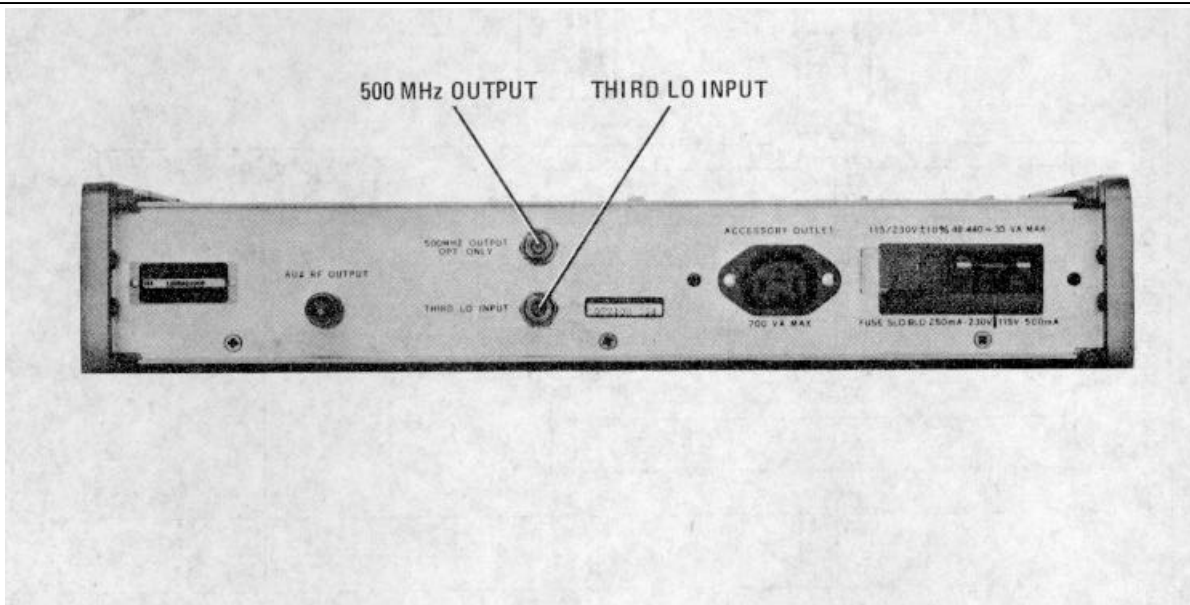

Figure D-1. 500 MHz LO Mounting location and Output Port for the 8444A, Option 058



When using the 8444A with an 8558B/180 Spectrum Analyzer the 8444A 500 MHz OUTPUT and its THRID LO INPUT must be interconnected with a short cable.

Figure D-2. Location of 500 MHz LO OUTPUT BNC Connector Added on Rear Panel of the 8444A, Option 058

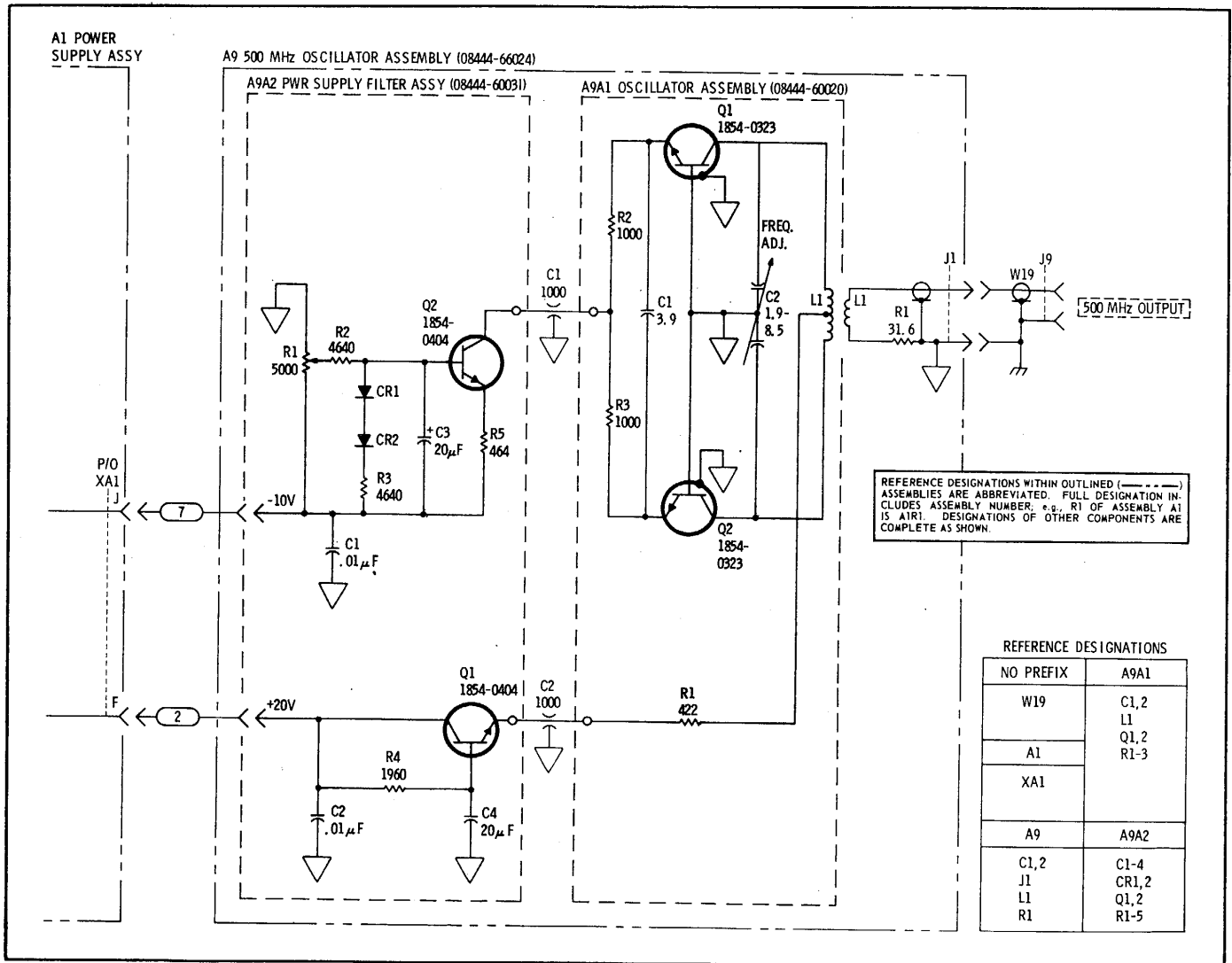

Figure D-3. A9 500 MHz Oscillator Assembly Schematic

APPENDIX E**REFERENCES**

DA Pam 310-4	Index of Technical Manuals, Technical Bulletins, Supply Manuals (Types 7, 8, and 9), Supply Bulletins, and Lubrication Orders.
DA Pam 310-7	US Army Equipment Index of Modification Work Orders.
TB 43-0118	Field Instructions for Painting and Preserving Electronics Command Equipment Including Camouflage Pattern Painting of Electrical Equipment Shelters.
TM 38-750	The Army Maintenance Management System (TAMMS).
TM 750-244-2	Procedures for Destruction of Electronics Materiel to Prevent Enemy Use (Electronics Command).

APPENDIX F

COMPONENTS OF END ITEM LIST

Section I. INTRODUCTION

F-1. Scope

This appendix lists integral components of and basic issue items for the SG-1 125/U to help you inventory items required for safe and efficient operation.

F-2. General

This Components of End Item List is divided into the following sections:

a. *Section II. Integral Components of the End Item.* These items, when assembled, comprise the SG1125/U and must accompany it whenever it is transferred or turned in. The illustrations will help you identify these items.

b. *Section III Basic Issue Items.* These are the minimum essential items required to place the SG-1125/U in operation, to operate it, and to perform emergency repairs. Although shipped separately packed they must accompany the SG-1125/U during operation and whenever it is transferred between accountable officers. The illustrations will assist you with hard-to-identify items. This manual is your authority to requisition replacement BII, based on TOFEMTOE authorization of the end item.

F-3. Explanation of Columns

a. *Illustration.* This column is divided as follows:

- (1) *Figure number.* Indicates the figure number of the illustration on which the item is shown.
- (2) *Item number.* The number used to

identify item called out in the illustration.

b. *National Stock Number.* Indicates the National stock number assigned to the item and which will be used for requisitioning

c. *Description.* Indicates the Federal item name and, if required, a minimum description to identify the item. The part number indicates the primary number used by the manufacturer, which controls the design and characteristics of the item by means of its engineering drawings, specifications, standards, and inspection requirements to identify an item or range of items. Following the part number, the Federal Supply Code for Manufactures (SCM) is shown in parentheses.

d. *Location.* The physical location of each item listed is given in this column. The lists are designed to inventory all items in one area of the major item before moving on to an adjacent area.

e. *Usable on Code.* Not applicable.

f. *Quantity Required (Qty Reqd).* This column lists the quantity of each item required for a complete major item.

g. *Quantity.* This column is left blank for use during an inventory. Under the Rcvd column, list the quantity you actually receive on your major item. The Date columns are for your use when you inventory the major item.

(Next printed page F-2)

SECTION II INTEGRAL COMPONENTS OF END ITEM

(1) ILLUSTRATION		(2) NATIONAL STOCK NUMBER	(3) DESCRIPTION		(4) LOCATION	(5) USUABLE ON CODE	(6) QTY REQD	(7) QUANTITY	
(A) FIG.	(B) ITEM		PART NUMBER	CAGE				RCVD	DATE
		6625-00-185-4802	GENERATOR, TRACKING SG-1125/U (HP 8444A)						

Change 1 F-2

SECTION III BASIC ISSUE ITEMS GENERATOR TRACKING SG-1125/U

(1) ILLUSTRATION		(2) NATIONAL STOCK NUMBER	(3) DESCRIPTION		(4) LOCATION	(5) USUABLE ON CODE	(6) QTY REQD	(7) QUANTITY	
(A) FIG.	(B) ITEM		PART NUMBER	CAGE				RCVD	DATE
			AC POWER CABLE 8120-1348						
			RACK MOUNTING KIT 5060-8739						
			INTERCONNECT CABLE 08444-60017						
			INTERCONNECT CABLES (3) 08444-60018						
			OPERATING AND SERVICE MANUAL 08444-90012						

Change 1 F-3/(F-4 blank)

APPENDIX G

ADDITIONAL AUTHORIZATION LIST

Section I. INTRODUCTION

G-1. Scope

This appendix lists additional items you are authorized for the support of the SG-1 125/U.

G-2. General

This list identifies items that do not have to accompany the SG1125/U and that do not have to be turned in with it. These items are all authorized to you by CIA, MTOE, TDA, or JTA.

G-3. Explanation of Listing

National stock numbers, descriptions, and quantities are provided to help you identify and request the additional items you require to support this equipment. The items are listed in alphabetical sequence by item name under the type document i.e., CTA, MTOE, TDA, or ITA) which authorizes the item(s) to you.

(Next printed page is G-2)

SECTION II ADDITIONAL AUTHORIZATION LIST

(1) NATIONAL STOCK NUMBER	(2) DESCRIPTION PART NUMBER AND FSCM USABLE ON CODE	(3) UNIT OF MEAS	(4) QTY AUTH
	JOINING BRACKET KIT HP 5060-8543 ACCESSORY POWER CORD HP 8120-1575 ACCESSORY POWER CORD HP 8120-1576		

Change 1 G-2

APPENDIX H

MAINTENANCE ALLOCATION

Section I. INTRODUCTION

H-1. General

This appendix provides a summary of the maintenance operations for SG-1125/U. It authorizes categories of maintenance for specific maintenance functions on repairable items and components and the tools and equipment required to perform each function. This appendix may be used as an aid in planning maintenance operations.

H-2. Maintenance Function

Maintenance functions will be limited to and defined as follows:

a. *Inspect.* To determine the serviceability of an item by comparing its physical, mechanical, and/or electrical characteristics with established standards through examination.

b. *Test.* To verify serviceability and to detect incipient failure by measuring the mechanical or electrical characteristics of an item and comparing those characteristics with prescribed standards.

c. *Service.* Operations required periodically to keep an item in proper operating condition, i.e., to clean (decontaminate), to preserve, to drain, to paint, or to replenish fuel, lubricants, hydraulic fluids, or compressed air supplies.

d. *Adjust.* To maintain, within prescribed limits, by bringing into proper or exact position, or by setting the operating characteristics to the specified parameters.

e. *Align.* To adjust specified variable elements of an item to bring about optimum or desired performance.

f. *Calibrate.* To determine and cause corrections to be made or to be adjusted on instruments or test measuring and diagnostic equipments used in precision measurement. Consists of comparisons of two instruments, one of which is a certified standard of known accuracy, to detect and adjust any discrepancy in the accuracy of the instrument being compared.

g. *Install.* The act of emplacing, seating, or fixing into position an item, part, module (component or assembly) in a manner to allow the proper functioning of the equipment or system.

h. *Replace.* The act of substituting a serviceable like type part, subassembly, or module (component or assembly) for an unserviceable counterpart.

i. *Repair.* The application of maintenance services (inspect, test, service, adjust, align, calibrate, replace) or other maintenance actions (welding, grinding, riveting, straightening, facing, remachining, or resurfacing) to restore serviceability to an item by correcting specific damage, fault, malfunction, or failure in a part, subassembly, module (component or assembly), end item, or system.

j. *Overhaul.* That maintenance effort

(service/action) necessary to restore an item to a completely serviceable/operations condition as prescribed by maintenance standards (i.e., DMWR) in appropriate technical publications. Overhaul is normally the highest degree of maintenance performed by the Army. Overhaul does not normally return an item to like new condition.

k. *Rebuild.* Consists of those services/actions necessary for the restoration of unserviceable equipment to a like new condition in accordance with original manufacturing standards. Rebuild is the highest degree of materiel maintenance applied to Army equipment. The rebuild operation includes the act of returning to zero those age measurements (hours, miles, etc.) considered in classifying Army equipments/components.

H-3. Column Entries

a. *Column 1, Group Number.* Column 1 lists group numbers, the purpose of which is to identify components, assemblies, subassemblies, and modules with the next higher assembly.

b. *Column 2, Component/Assembly.* Column 2 contains the noun names of components, assemblies, subassemblies, and modules for which maintenance is authorized.

c. *Column 3, Maintenance Functions.* Column 3 lists the functions to be performed on the item listed in column 2. When items are listed without maintenance functions, it is solely for purpose of having the group numbers in the MAC and RPSTL coincide.

d. *Column 4, Maintenance Category.* Column 4 specifies, by the listing of a "work time" figure in the appropriate subcolumn(s), the lowest level of maintenance authorized to perform the function listed in column 3. This figure represents the active time required to perform that maintenance function at the indicated category of maintenance. If the number or complexity of the tasks within the listed maintenance function vary at different maintenance categories, appropriate "work time" figures will be shown for each category. The number of taskhours specified by the "work time" figure represents the average time required to restore an item (assembly, subassembly, component, module, end item or system) to a serviceable condition under typical field operating conditions. This time includes preparation time, troubleshooting time, and quality assurance/quality control time in addition to the time required to perform the specific tasks identified for the maintenance functions authorized in the maintenance allocation chart. Subcolumns of column 4 are as follows:

C -- Operator/Crew
O -- Organizational
F-- Direct Support

H-General Support

D-Depot

e. *Column 5, Tools and Equipment.* Column 5 specifies by code, those common tool sets (not individual tools) and special tools, test, and support equipment required to perform the designated function.

f. *Column 6, Remarks.* Column 6 contains an alphabetic code which leads to the remark in section IV, Remarks, which is pertinent to the item opposite the particular code.

**H-4. Tool and Test Equipment Requirements
(Sec III)**

a. *Tool or Test Equipment Reference Code.* The numbers in this column coincide with the numbers used in the tools and equipment column of the MAC. The numbers indicate the applicable tool or test equipment for the maintenance functions.

b. *Maintenance Category.* The codes in this column indicate the maintenance category allocated the

tool or test equipment.

c. *Nomenclature.* This column lists the noun name and nomenclature of the tools and test equipment required to perform the maintenance functions.

d. *National/NATO Stock Number.* This column lists the National/NATO stock number of the specific tool or test equipment.

e. *Tool Number.* This column lists the manufacturer's part number of the tool followed by the Federal Supply Code for manufacturers (5-digit) in parentheses.

H-5. Remarks (Sec IV)

a. *Reference Code.* This code refers to the appropriate item in section II, column 6.

b. *Remarks.* This column provides the required explanatory information necessary to clarify items appearing in section II.

(Next printed page is H-3)

**SECTION II. TOOL AND TEST EQUIPMENT REQUIREMENTS
FOR
GENERATOR TRACKING SG-1125/U**

(1) GROUP NUMBER	(2) COMPONENT ASSEMBLY	(3) MAINTENANCE FUNCTION	(4) MAINTENANCE CATEGORY					(5) TOOLS AND EQUIPMENT	(6) REMARKS	
			C	O	F	H	D			
00	GENERATOR TRACKING SG-1125/U	Inspect Test Adjust Repair	0.2			3.0 1.5 1.0	2.0	1 thru 17 1 thru 13, 17 thru 21 1 thru 13, 17 thru 21	A	
01	POWER SUPPLY BOARD ASSEMBLY A2	Overhaul Inspect Test				3.0 0.2 1.0		1 thru 21 10,11,17, 18		
		Adjust Replace Repair Overhaul				0.2 0.5 0.5 0.1		20, 21 20, 21 20, 21 20, 21		
02	DRIVER BOARD ASSEMBLY A2	Inspect Test				0.2		1 thru 3, 8 thru 13 17		
		Adjust Replace Repair overhaul				0.5 0.5 1.0 1.5		20, 21 20, 21 20, 21 20, 21		
03	AMPLIFIER AND DETECTOR ASSEMBLY A3	Test				0.5		1 thru 3, 17		
04	AMPLIFIER ASSEMBLY A4	Replace Inspect Test				0.3 0.5		20, 21 1 thru 3, 8 thru 12 17		
		Replace Repair Overhaul				0.5 1.0 1.0		20, 21 20, 21 20, 21		
05	FIRST CONVERTER ASSEMBLY A5	Inspect Test				0.1 1.0		1 thru 3, 8 thru 12 17		
		Adjust Replace				0.5	0.5	20, 21 20, 21		
0501	FIRST MIXER ASSEMBLY A5A1	Repair Replace					0.5 0.5	20, 21 20, 21		B
06	SECOND CONVERTER ASSEMBLY A6	Inspect Test				0.2 0.5		1 thru 3 8 thru 12 17		
							0.5	20, 21		
07	OSCILLATOR ASSEMBLY A7	Inspect Adjust Replace				0.2 0.5	0.5	20, 21 20, 2		

**SECTION III TOOL AND TEST EQUIPMENT REQUIREMENTS
FOR
GENERATOR TRACKING SG-1125/U**

(1) TOOL OR TEST EQUIPMENT REF CODE	(2) MAINTENANCE LEVEL	(3) NOMENCLATURE	(4) NATIONAL/NATO STOCK NUMBER	(5) TOOL NUMBER
1	H, D	ANALYZER SPECTRUM IP-1216(P)/GR	6625-00-424-4370	
2	H, D	PLUG-IN UNIT SPECTRUM ANALYZER PL-1406/U	6625-00-140-0156	
3	H, D	PLUG-IN UNIT ELECTRONIC TEST EQUIPMENT PL-1388/U	6625-00-431-9339	
4	H, D	GENERATOR SIGNAL SG-1129/U	6625-00-937-3525	
5	H, D	ANALYZER SPECTRUM IP-1216(P)/GR	6625-00-424-4370	
6	H, D	PLUG-IN UNIT ELECTRONIC TEST EQUIPMENT PL-1399/U	6625-00-432-5055	
7	H, D	PLUG-IN UNIT ELECTRONIC TEST EQUIPMENT PL-1388/U	6625-00-431-9339	
8	H, D	POWER METER, HEWLETT PACKARD 436A	6625-01-033-5050	
9	H, D	POWER SENSOR, HEWLETT PACKARD 8482A	6625-01-015-4412	
10	H, D	VOLTMETER IS-185	6625-00-405-6608	
11	H, D	MULTIMETER, ME-303A/U	6625-00-969-4105	
12	H, D	COUNTER ELECTRONIC TD-1225(V)1/U	6625-00-498-8946	
13	H, D	GENERATOR SIGNAL AN/USM-205A	6625-01-007-4796	
14	H, D	GENERATOR SIGNAL AN/GRM-SOC	6625-00-003-3238	
15	H, D	GENERATOR SIGNAL AN/USM-44B	6625-00-126-5708	
16	H, D	GENERATOR SIGNAL SG-340A/G	6625-00-542-1292	
17	H, D	VOLTMETER DIGITAL AN/GSM-64B	6625-00-022-7894	
18	H, D	TRANSFORMER, VARIABLE POWER CN-16/U	5950-00-235-2086	
19	H, D	POWER SUPPLY, DUAL DC- HP 6205B	6625-00-437-4861	
20	H, D	TOOL KIT TK-100/G	5180-00-605-0079	
21	H, 0	COMMON TOOLS NECESSARY TO THE PERFORMANCE OF THIS MAINTENANCE FUNCTION ARE AVAILABLE TO MAINTENANCE PERSONNEL FOR THE MAINTEN- ANCE CATEGORY LISTED.		

**SECTION IV. REMARKS
GENERATOR TRACKING SG-1125/U**

REFERENCE CODE	REMARKS
A	VISUAL
B	REPAIR BY REPLACEMENT OF DIODE ASA1CR1

* U.S. GOVERNMENT PRINTING OFFICE: 1980-765-016/1104

H-5/(H-6 blank)

APPENDIX I

REPAIR PARTS AND SPECIAL TOOLS LIST

Refer to Section VI, Replaceable Parts, for all maintenance parts.

RECOMMENDED CHANGES TO EQUIPMENT TECHNICAL PUBLICATIONS



THEN... JOT DOWN THE DOPE ABOUT IT ON THIS FORM, CAREFULLY TEAR IT OUT, FOLD IT AND DROP IT IN THE MAIL!

SOMETHING WRONG WITH THIS PUBLICATION?

FROM: (PRINT YOUR UNIT'S COMPLETE ADDRESS)

DATE SENT

PUBLICATION NUMBER

PUBLICATION DATE

PUBLICATION TITLE

BE EXACT... PIN-POINT WHERE IT IS

IN THIS SPACE TELL WHAT IS WRONG AND WHAT SHOULD BE DONE ABOUT IT:

PAGE NO.	PARA-GRAPH	FIGURE NO.	TABLE NO.
----------	------------	------------	-----------

TEAR ALONG PERFORATED LINE

PRINTED NAME, GRADE OR TITLE, AND TELEPHONE NUMBER

SIGN HERE:

DA FORM 2028-2 JUL 79

PREVIOUS EDITIONS ARE OBSOLETE.

P.S.—IF YOUR OUTFIT WANTS TO KNOW ABOUT YOUR RECOMMENDATION MAKE A CARBON COPY OF THIS AND GIVE IT TO YOUR HEADQUARTERS.

